

USER MANUAL

Glas Craft
DISPENSING EXCELLENCE

Spartan II

RTM Injection System

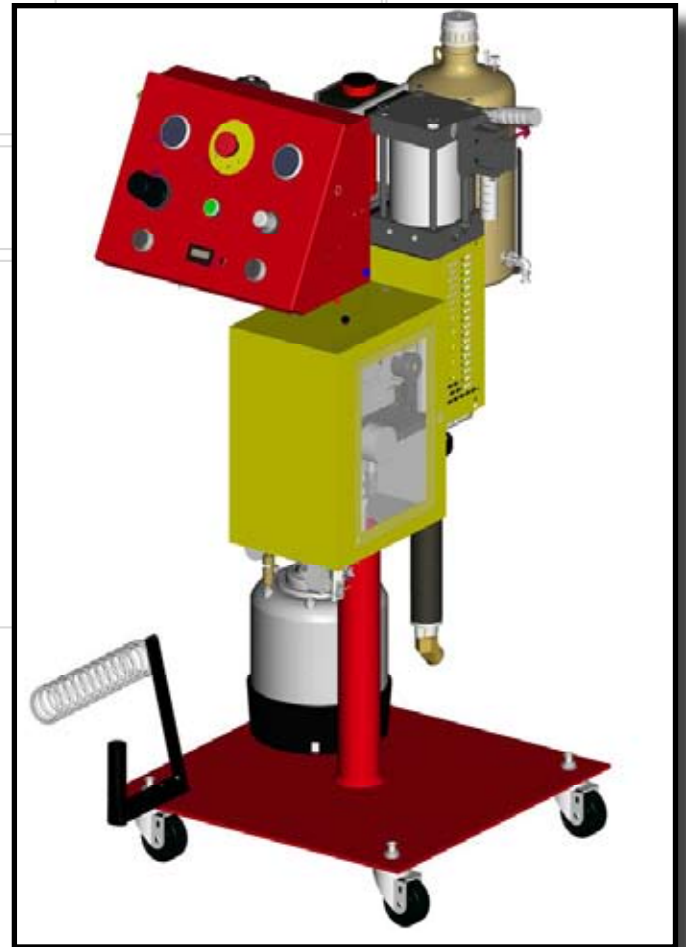

Table Of Contents

Section 1 Installation

1:1 Introduction	1
1:2 Standard Equipment	2
1:3 Specifications	N/A
1:4 Equipment Assembly	3

Section 2 Operation

2:1 Start-up Instructions	6
2:2 Shut-down Instructions	11

Section 3 General Information

3:1 Assembly Drawings	12
3:2 Sub-Assembly Drawings	17
3:3 Maintenance	27
3:4 Troubleshooting	28
3:5 Options	29

Section 4 Safety Information

4:1 General Safety	34
4:2 Notes	42
4:3 Limited Warranty Policy	43
4:4 Technical Assistance	44

For Your Reference INSIDE BACK COVER

N/A= Not Applicable

Section 1- Installation: Introduction

Introduction

Before operating, maintaining or servicing any **GlasCraft** system, read and understand all of the technical and safety literature provided with **GlasCraft** products. If you do not have the proper or related manuals and safety literature for your **GlasCraft** system, contact your **GlasCraft** distributor or **GlasCraft, Inc.**

In this **GlasCraft** technical and safety publication, the following advisories will be provided where appropriate:



Is information about the procedure in progress.



Is imperative information about equipment protection.



Indicates a hazardous situation which, if not avoided, could result in minor or moderate injury.



Indicates a hazardous situation which, if not avoided, could result in death or serious injury.



Indicates a hazardous situation which, if not avoided, could result in electrical shock or serious injury.

The information in this document is intended only to indicate the components and their normal working relationship typical use. Each assembly should be directed by a **GlasCraft** distributor or made from the **GlasCraft** Assembly instructions provided.

This manual provides information for the assembly, operation, maintenance and service of this **GlasCraft** product as used in a typical configuration. While it lists standard specifications and procedures, some deviations may be found.

In order to provide our users with the most up-to-date technology possible, we are constantly seeking to improve products. If technological change occurs after a product is on the market, we will implement that technology in future production and, if practical, make it available to current users as a retrofit, up-date or supplement. If you find some discrepancy between your unit and the available documentation, contact your **GlasCraft** distributor to resolve the difference. **GlasCraft, Inc.** reserves the right to change or modify this product as it deems necessary.

Careful study and continued use of this manual will provide a better understanding of the equipment and process, resulting in more efficient operation, longer trouble-free service and faster, easier troubleshooting.

Section 1- Installation: Standard Equipment

Sec1:2

Spartan II System

Standard Equipment	
Part Number	Description
20864-06	MATERIAL PUMP ASSEMBLY, 13:1 RATIO
SSP-160-01	SUPER CATALYST SLAVE PUMP ASSEMBLY
21661-00	AIR LOGIC ASSEMBLY
20941-00	CATALYST BOTTLE ASSEMBLY
LPA-169	CATALYST BOTTLE BRACKET ASSEMBLY
18291-01 / 20569-01	BASE & MAST
21654-00	SOLVENT TANK ASSEMBLY
GAM-268-01	MATERIAL PUMP PICK-UP KIT
21694-25	MATERIAL HOSE ASSEMBLY, 25 FT.
20195-30	MATERIAL RECIRCULATION HOSE
17440-00	GROUNDING CLAMP ASSEMBLY
20190-30	CATALYST HOSE 30 FT.
20945-00	CATALYST RECIRCULATION HOSE
21054-01	SOLVENT HOSE 38 FT.
21668-01	GUN ASSEMBLY
23220-00	CONTROL BOX ASSEMBLY
GC-1355	MANUAL

Section 1 - Installation: Equipment Assembly

The Spartan II comes complete and fitted with all resin hoses, catalyst bottle and filters. The injection head is fully connected to the machine circuit and tested and secured against leaks prior to dispatch.

 The following instructions are to be used as a guide for consistent and continual operation. Any deviation from the "standard operation", usually requires more maintenance to the equipment and material formulation to assure consistent results. For example: the use of fillers in resins.

 Refer to specific user manuals (if available) for detailed component start-up and shut-down instructions.

1. Select a clean, dry air supply.
It is very important to have a clean air supply.

2. Attach a 3/8" or larger air hose to the Air Inlet on the yellow air lock-out valve. Quick disconnect fittings should not be used because they can severely limit air flow.

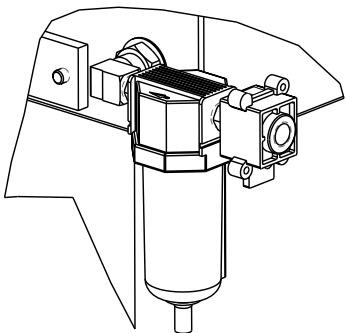

CAUTION

Before turning on main air:

- a. check all fittings, making certain they are securely tightened.
- b. Make sure all regulators are set to zero (turn all the way to the left).

This should be done before air or material of any kind is introduced into the system.

3. Attach Grounding Clamp Assembly, P/N 17440-00, to System. Use a convenient Nut and Bolt to secure Lug, P/N 13193-00, to system.
4. Securely attach Clamp, P/N 7749-00 to permanently grounded rod or pipe.

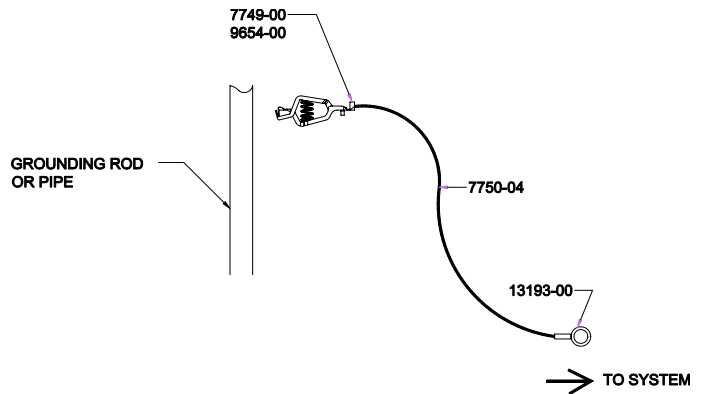

CAUTION

Whenever flammable or combustible liquids are transferred from one container to another, both containers shall be effectively bonded and grounded to dissipate static electricity.

For further information see.....
NFPA 77, Recommended Practice on Static Electricity.

5. Remove the pump inlet safety cap and drain the testing oil into an open container.
6. Attach 4 casters with provided lock washer, washer and nut. Attach solvent tank support rod on back left caster.

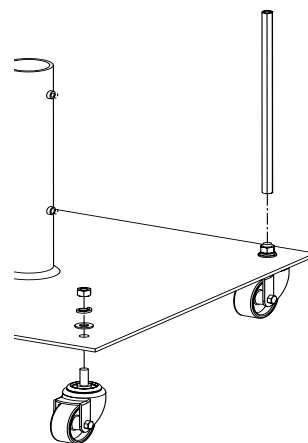

7. Attach solvent tank to solvent tank support rod with provided rubber strap.

Section 1 - Installation: Equipment Assembly

Sec. 1:4

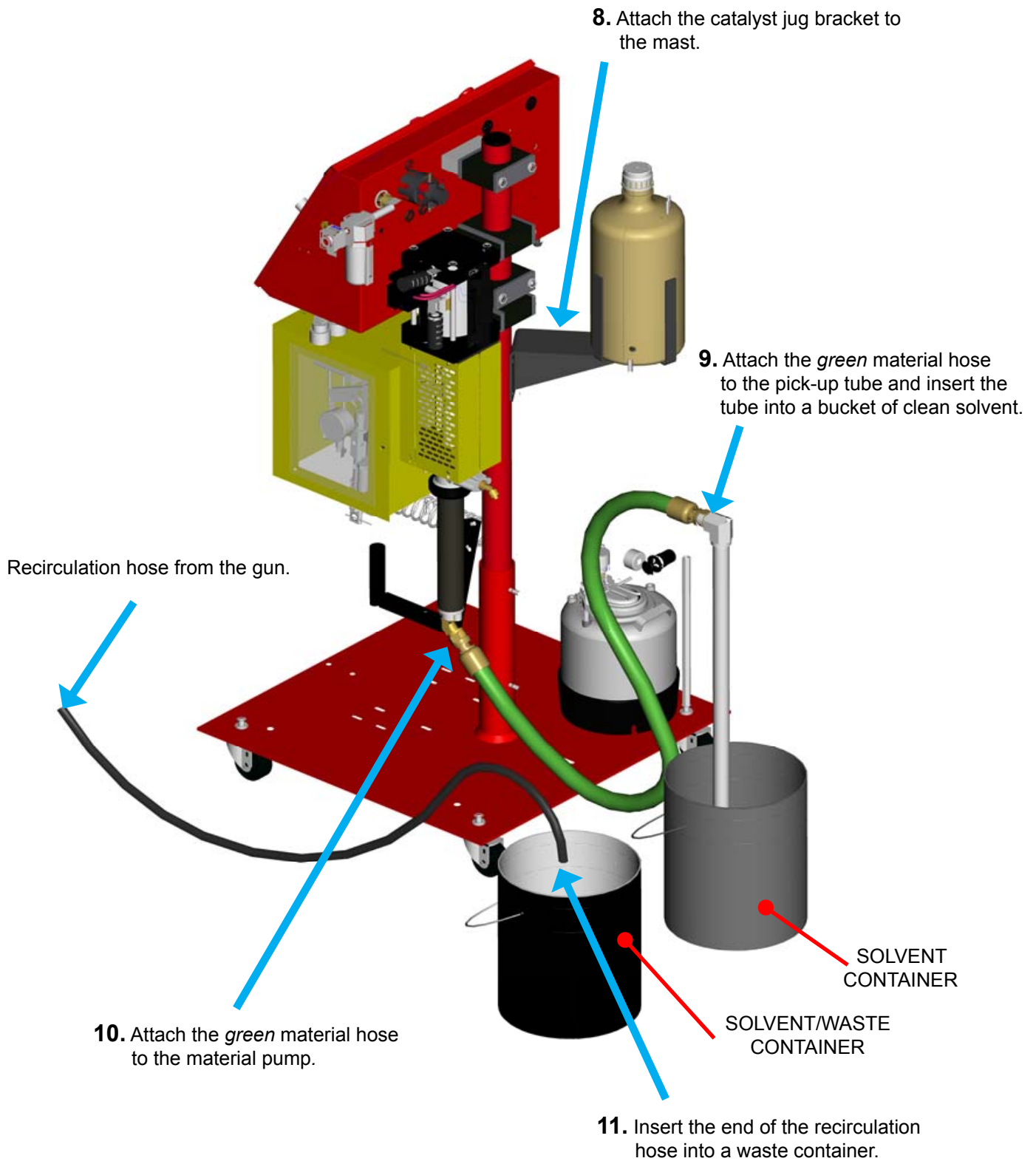

Section 1 - Installation: Equipment Assembly

12. Make sure solvent regulator is dialed to zero.
(Turn knob fully counter-clockwise)

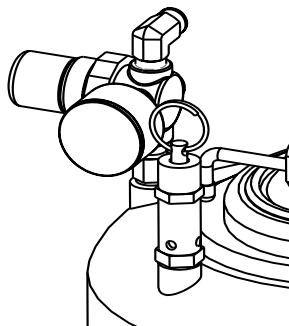

13. Carefully relieve any pressure in the solvent tank by slowly pulling the relief valve.

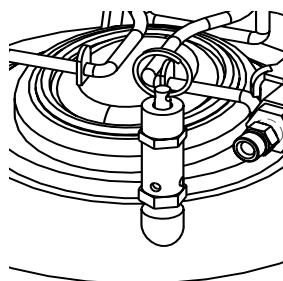

14. After all the pressure is released from the tank, open the lid and fill the tank with a suitable, clean flushing solvent and close the lid securely.

15. Remove yellow guard using a 5/32" hex balldriver.

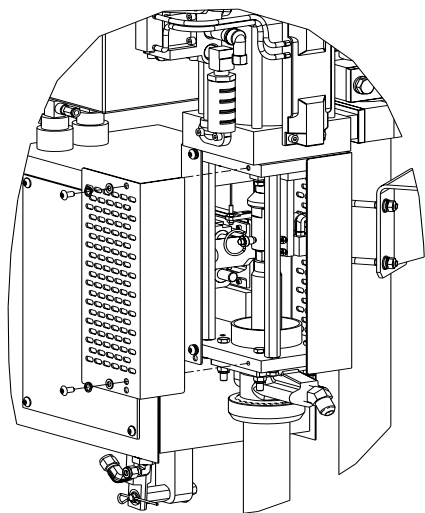

16. Fill material pump lube cup with proper pump lube.

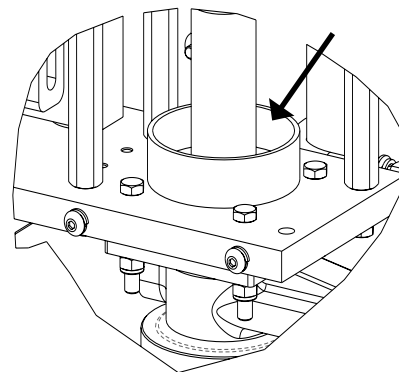

17. Replace yellow guard using a 5/32" hex balldriver.

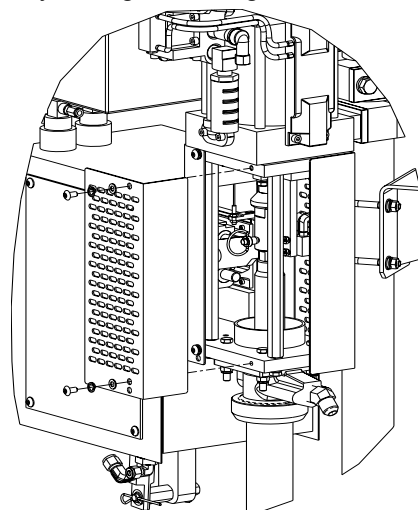

18. Before operating the material pump, flush thoroughly with a clean, suitable solvent to remove test fluid.



GlasCraft uses test fluid that may not be compatible with some resins. It is recommended that the test fluid be flushed from the material pump fluid section. Make sure hose fittings on the pick-up hoses are tight.

19. Safely fill the Catalyst Supply Bottle, P/N LPA-165, (maximum two gallons) with preferred MEKP catalyst, to a minimum level of at least two inches above the Catalyst Bottle Outlet Fitting.

WARNING

Remove Catalyst Bottle, P/N 20941-00 from Catalyst Bottle bracket, P/N LPA-169 for filling. Bottle should be placed at or below lowest level for safe filling. Never fill Catalyst bottle while mounted in bracket as personal injury from catalyst spillage could result.

Section 2 - Operation: Start-Up Instructions

The Spartan II comes complete and fitted with all resin hoses, catalyst bottle and filters. The injection head is fully connected to the machine circuit and tested and secured against leaks prior to dispatch.

Sec. 2:1

 The following instructions are to be used as a guide for consistent and continual operation. Any deviation from the "standard operation", usually requires more maintenance to the equipment and material formulation to assure consistent results. For example: the use of fillers in resins.

 Refer to specific user manuals (if available) for detailed component start-up and shut-down instructions.

Solvent

Before initial operation of any internal mix system, make certain the solvent flush set-up is fully operational.

1. Turn solvent regulator clockwise to approximately 65 psi.

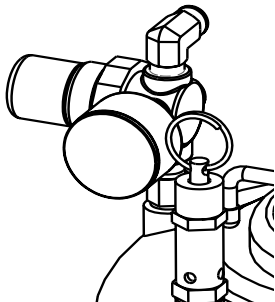

2. Place injection nozzle over a proper waste container. Turn 3-way valve on top of the solvent tank so the arrow is pointing up for air purge, for solvent turn the valve so the arrow is pointing down. Repeat air purge to blow solvent through the gun head.

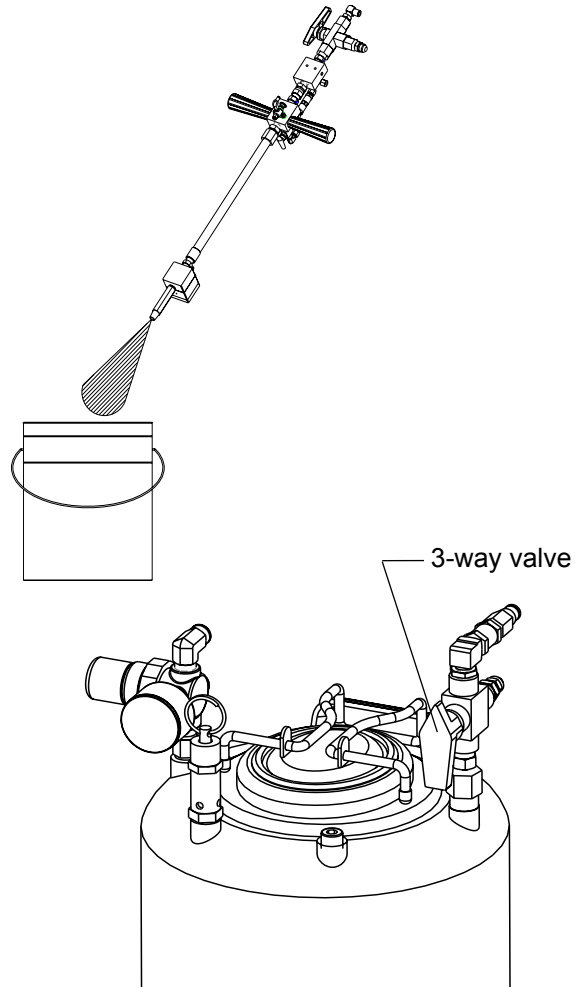

3. Exhaust air through the gun head until traces of solvent have been dissipated.



Since the system is an internal mix system, the mixer requires flushing with air-solvent-air after each dispense or before the mixed material starts to gel.

Section 2 - Operation: Start-Up Instructions

Resin

1. Detach the catalyst slave pump from the material pump.
Pull and rotate knob to disengage the catalyst drive arm.

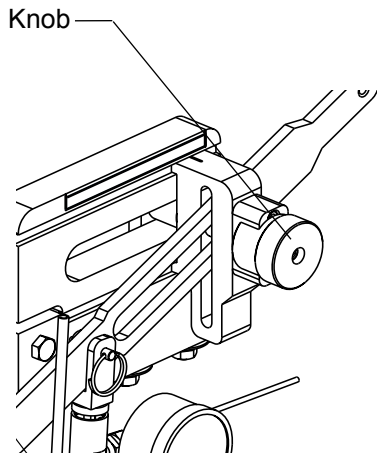

2. Turn main valve on the gun head to the recirculation position.

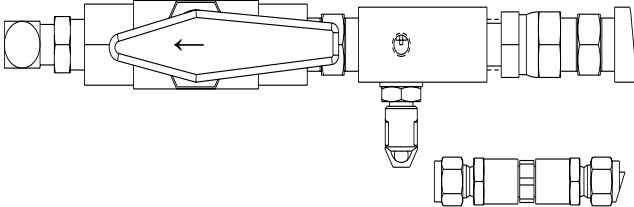

3. Turn the material air regulator fully counter-clockwise.

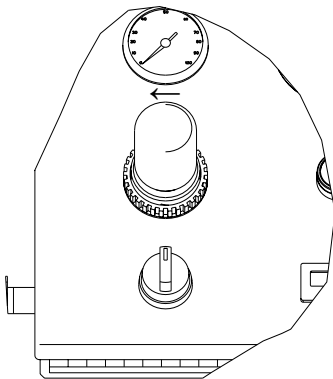

4. Switch machine recirculation to "ON".

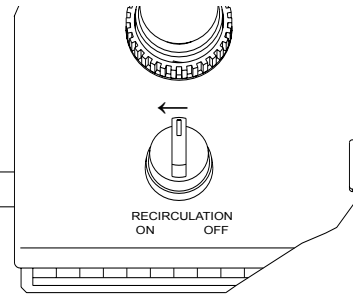

5. Turn the material injection regulator slowly clockwise until gauge indicates 10 PSI or until pump cycles slowly.

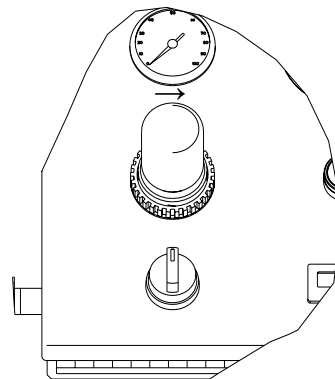

8. Pump should cycle clean solvent through the system and out the recirculation hose.

9. End recirculation when solvent appears reasonably clean. "OFF"

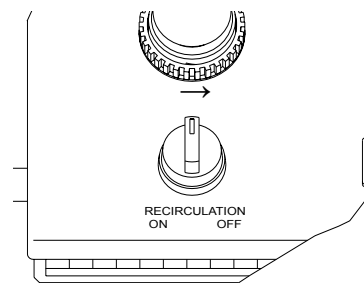

10. Remove material pump pick-up tube from solvent container and dry thoroughly.

Section 2 - Operation: Start-Up Instructions

Sec. 2:1

11. Switch machine recirculation to "ON".

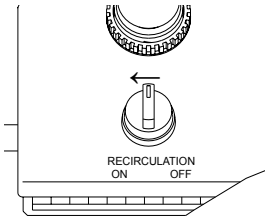

12. When solvent has stopped exiting the recirculation hose, end recirculation. (OFF)

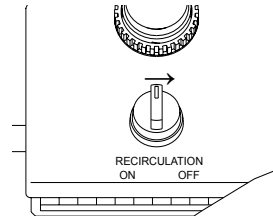

13. Place material pump pick-up tube in desired container of material while keeping recirculation return hose in a waste container.

14. Turn machine to recirculation. (ON)

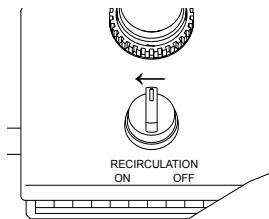

15. Let material pump cycle slowly until a steady stream of clean material is seen exiting the recirculation hose.

16. Switch machine recirculation to "OFF".

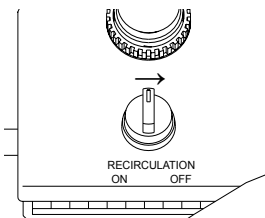

17. Secure recirculation hose in the material supply container.



Dispose of resin in the waste container in a proper manner.

Catalyst

1. Turn Catalyst Valve on the dispense gun to recirculation position (arrow on valve should point away from gun block).

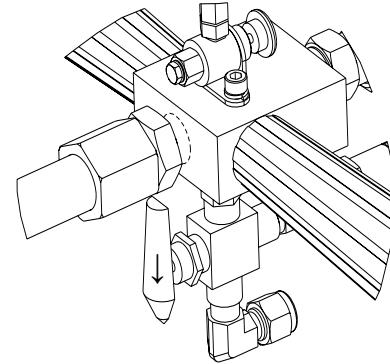

Make sure all the air is purged out of the catalyst pump on new start up.

- 2a. Pull and rotate Pivot knob to disengage the catalyst drive arm.

- b. Turn the slave pump yellow ball valve to the open position.

- c. Hand prime the pump until a steady stream of catalyst flows back to the bottle.

- d. Close the ball valve. Hand stroke the pump until it develops 50-60 PSI.

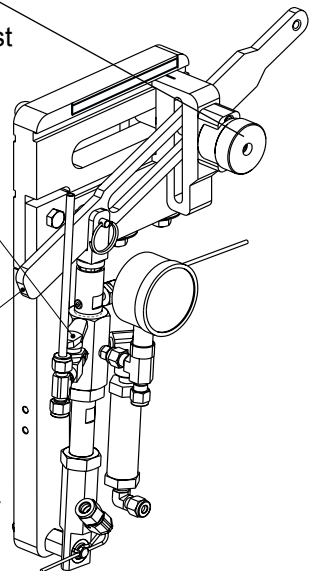

3. Set the slave pump to 3.5 percent.

Section 2 - Operation: Start-Up Instructions



It is usually a general practice when starting up the system to let the system recirculate with the Catalyst Slave Pump set at 3.5%. This ensures good catalyst volume movement through the system to remove air in the catalyst system.

4. Re-engage the catalyst pivot knob.



Make sure that the knob engages inside the catalyst drive arm slot. Failure to do so will cause damage to the catalyst drive arm

Recirculation Mode (Start-Up)

1. Both Catalyst Valve and Material Valve on the Dispense Gun should be in the Recirculation position.

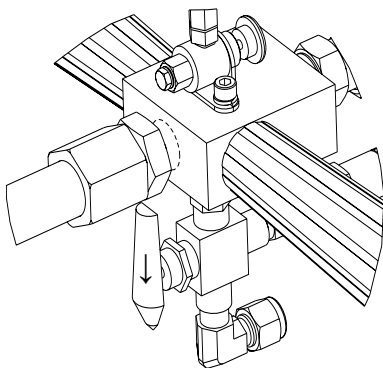
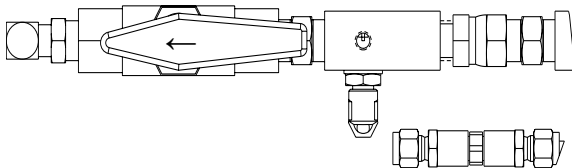

2. Switch machine recirculation to "ON".

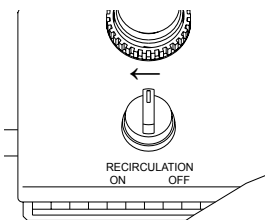

3. Turn air motor pressure regulator slowly clockwise until pump cycles slowly.

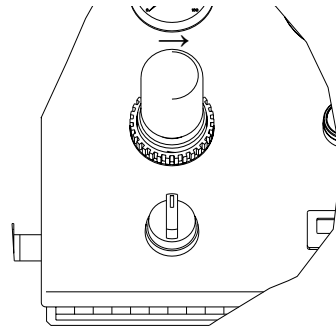

The Recirculation Mode should be used in initial start-up or when air bubbles are observed coming through the ends of the Recirculation Hoses.

Injection Instructions

1. Switch machine to injection. (set recirculation to off)

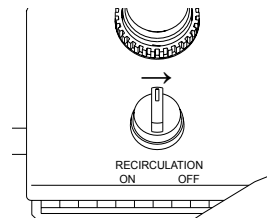

2. Turn valves on gun head to injection.

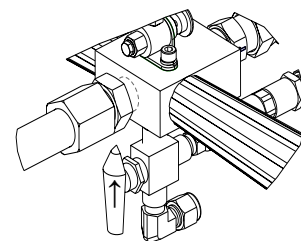
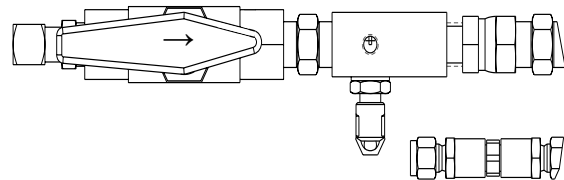

⚠ CAUTION

When making test material dispenses or during flushing operation, make certain that dispensed material and/or solvent is contained in a suitable container and that this material and/or solvent is disposed of properly.

Section 2 - Operation: System Start-up

7. Flush gun head thoroughly. Turn 3-way valve on top of the solvent tank so the arrow is pointing up for air purge, for solvent turn the valve so the arrow is pointing down.

Sec2:1

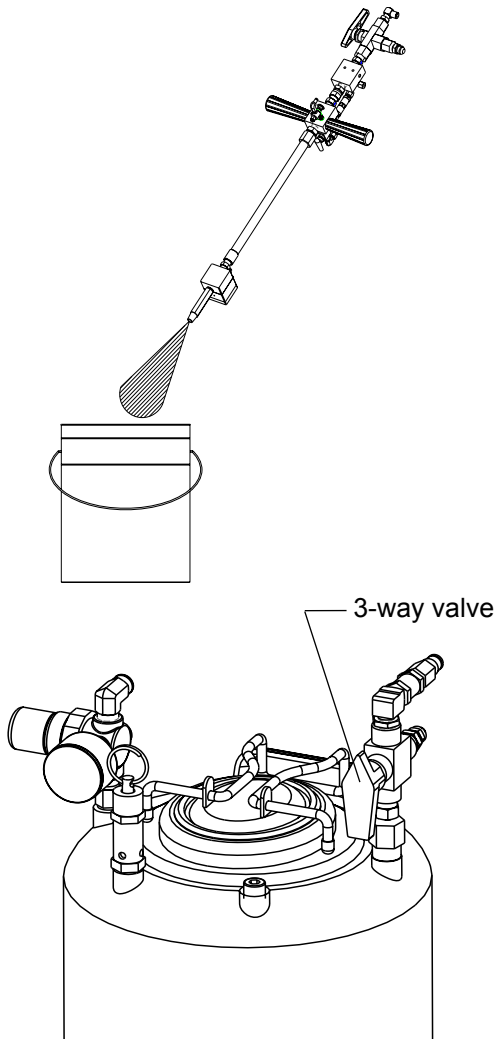

Section 2 - Operation: System Shut Down

Shut Down Procedure

The purpose of the shut down procedure is to verify that all critical parts of the system, i.e., the mixing area, have been checked and cleaned to assure trouble-free start-up the next time the system is to be operated.

1. Turn both ball valves on gun head to "OFF". (90°)

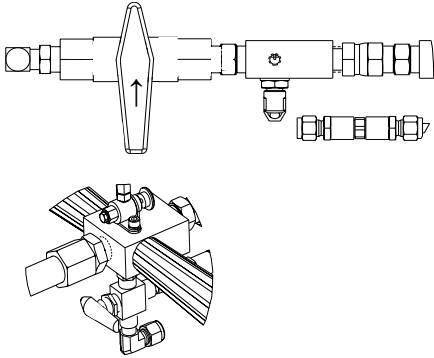

If using a filled resin it is suggested that the material pump and hoses be flushed with a "neat" resin and that the neat resin is flowing through the system and exiting the material recirculation hose thoroughly before shut down procedures are completed.

2. Flush gun head with solvent and air purge thoroughly.
3. Material pump should be stopped with pump shaft in up position and shaft should be cleaned of any contaminants.

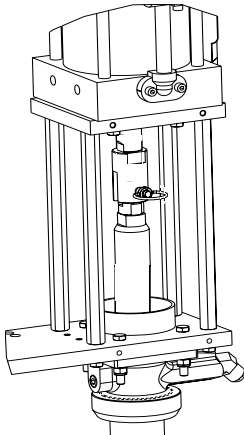

4. Material pump lube cup should be cleaned of old lube and refilled with new pump lube.

5. Material pump should now be cycled so that shaft is left in down position during shut-down period.

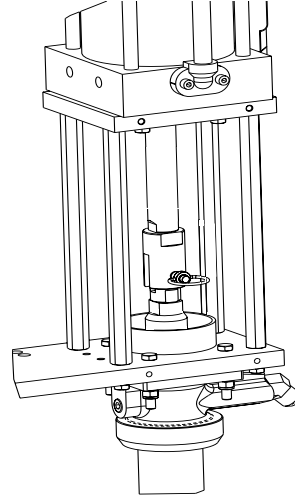

6. If you are using fillers mixed into the resin, remember on periods of shut-down, the fillers can settle to the bottom of the pump and pipe-works.
7. Shut down main air supply by closing yellow lock out valve.

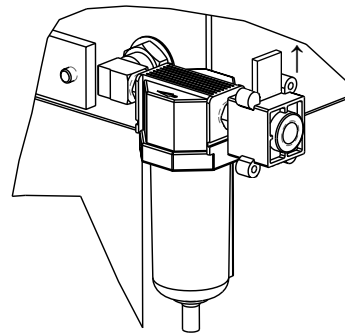

8. Slowly bleed the air pressure from the tank by lifting the ring on the relief valve.

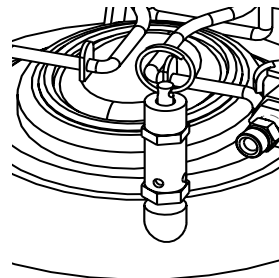

Failure to cycle Pump Shaft to DOWN position may result in contaminants to dry or harden on shaft. When pump is next operated, severe damage may be done to upper pump seals.

Section 3 - General Information: Assembly Drawings

23200-00 Unit Assembly

Sec3:1

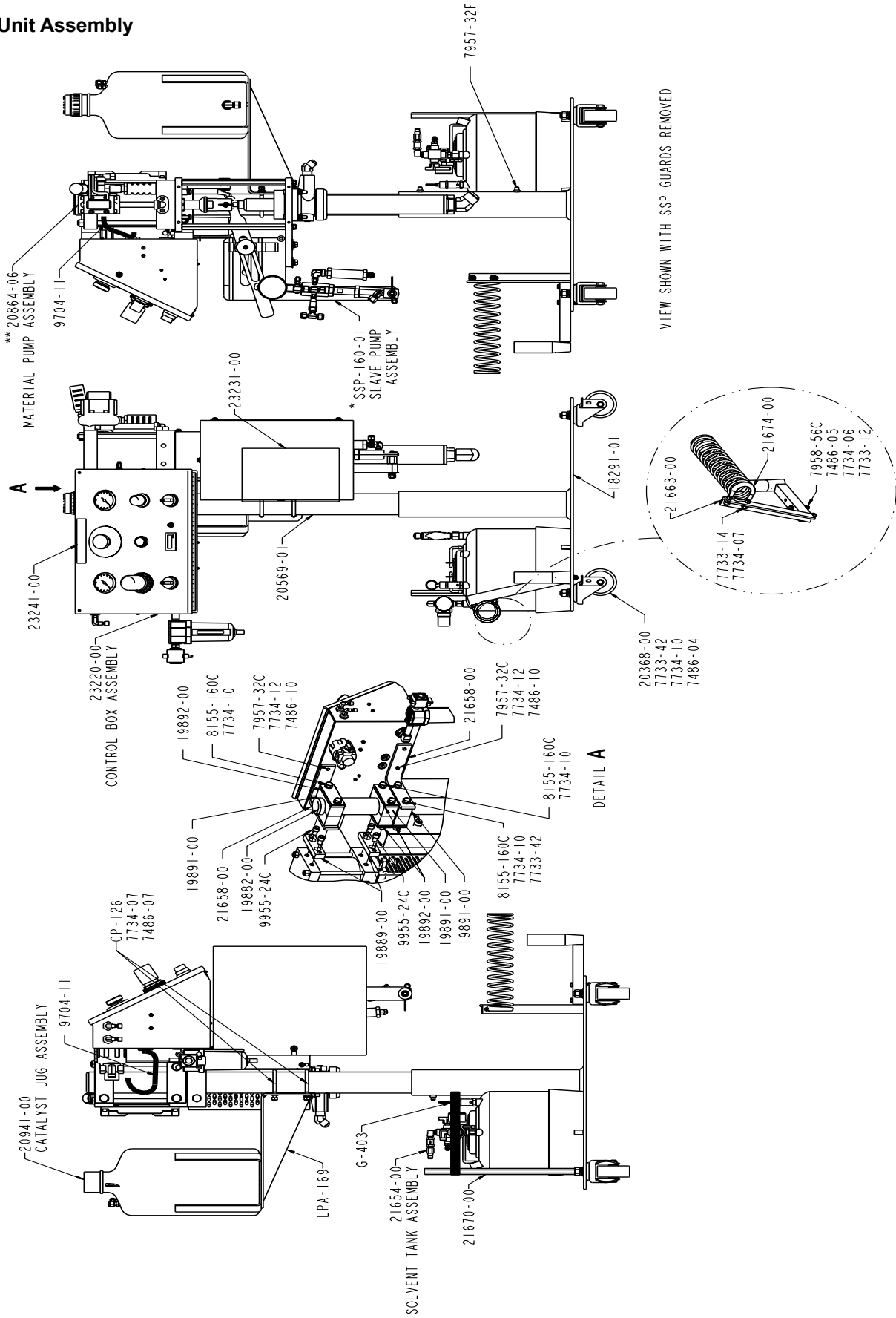

* For a detailed view, see GC-1337

** For a detailed view, see GC-1303

Section 3 - General Information: Assembly Drawings

23200-00 Unit Assembly

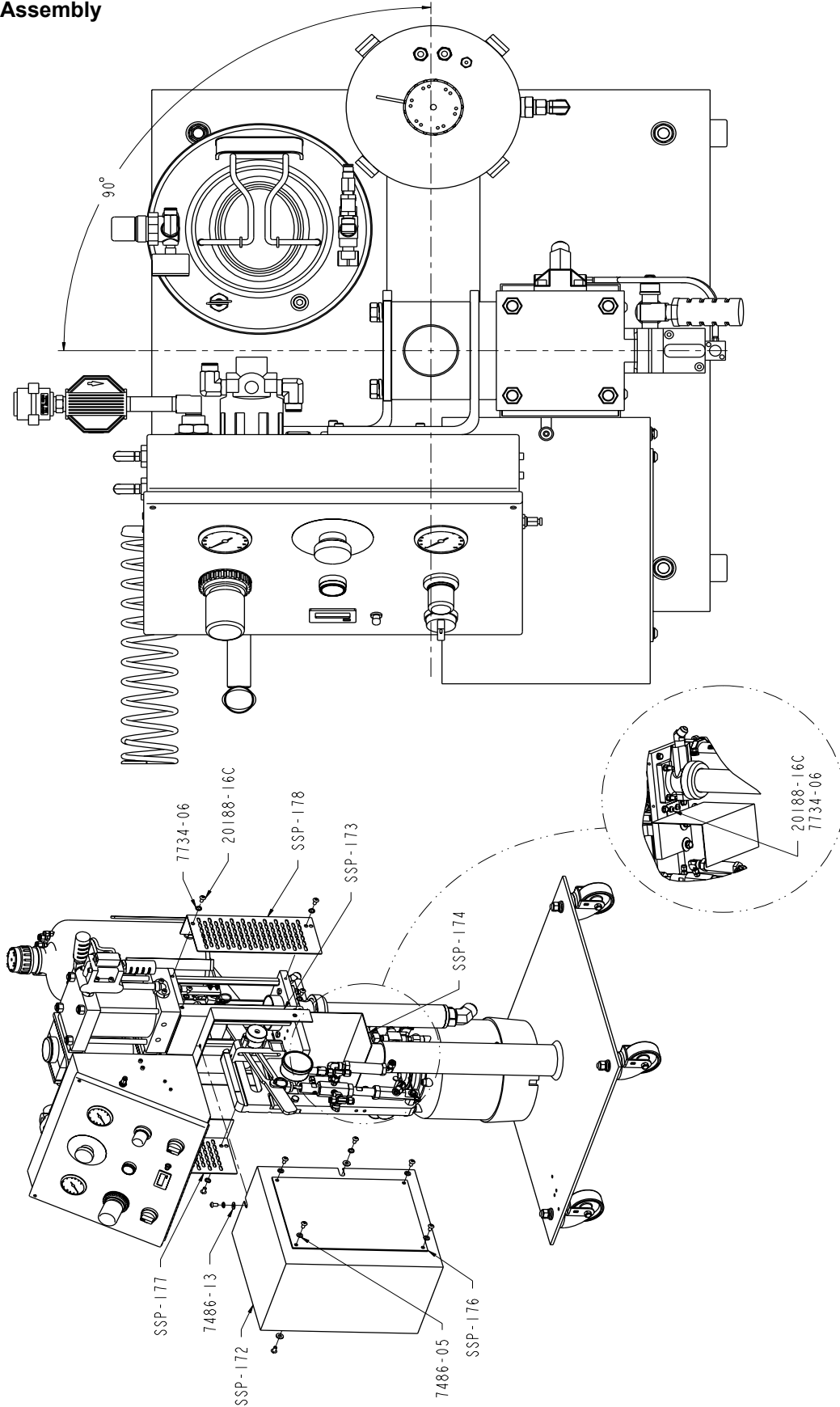

Sec3:1

Section 3 - General Information: Assembly Drawings

23200-00 Unit Assembly

Sec3:1

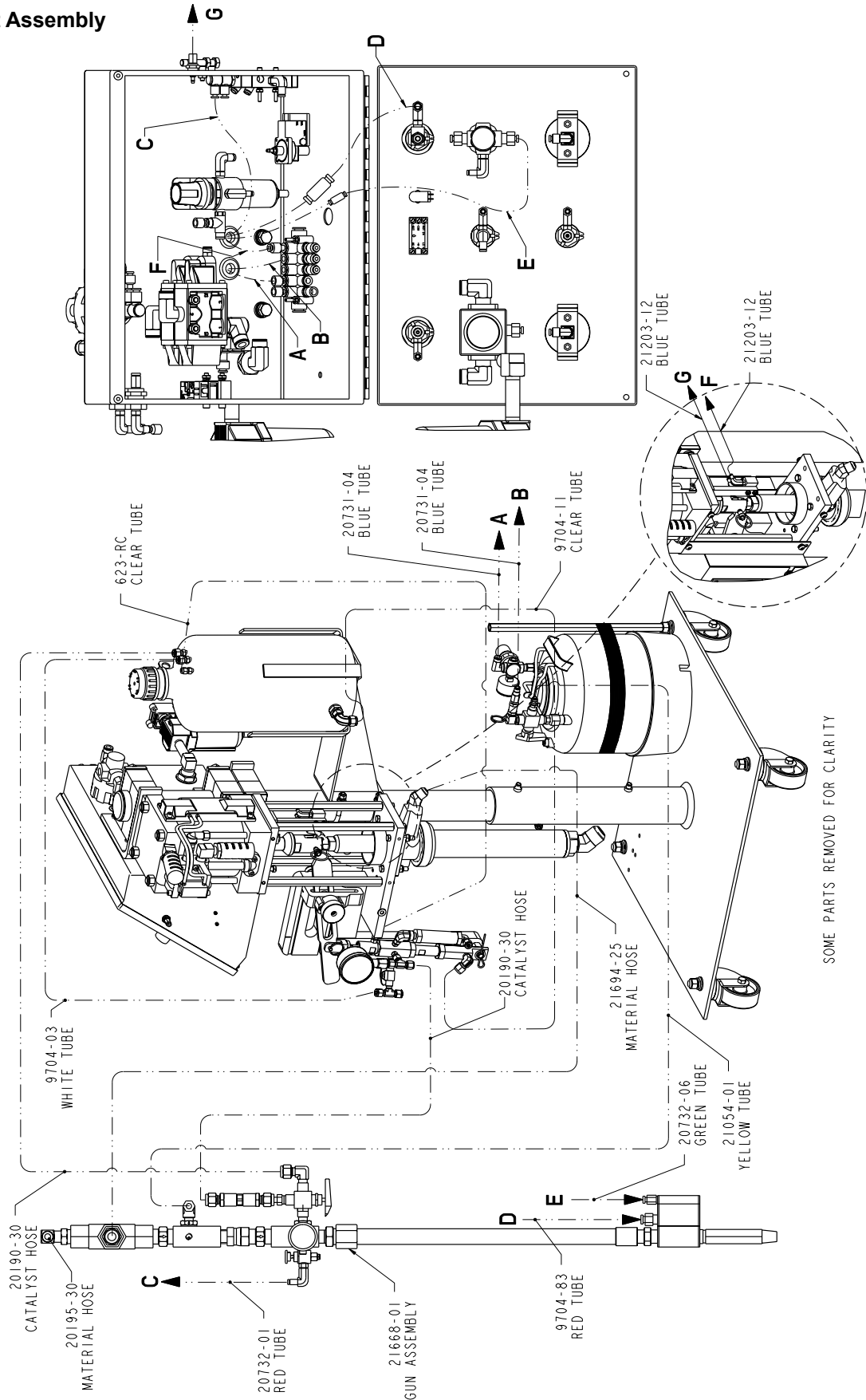

SOME PARTS REMOVED FOR CLARITY

SOME PARTS REMOVED FOR CLARITY

Section 3 - General Information: Assembly Drawings

23200-00 Hose Diagram

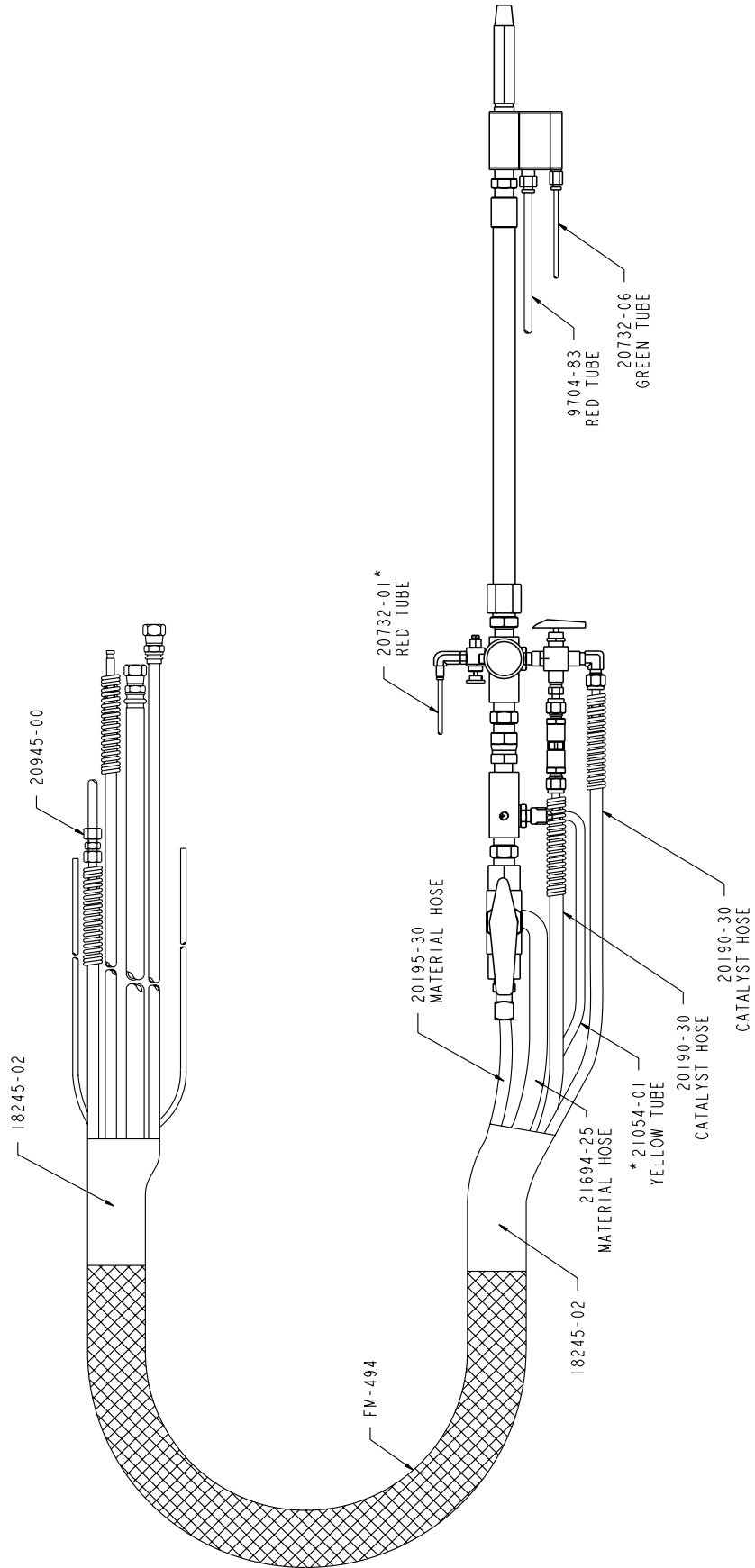

* Part numbers 20732-01
and 21054-01 go inside of
9704-09.

Section 3 - General Information: Assembly Drawings

23200-00 Unit Assembly

Part Number	Description
CP-126	U-BOLT
FM-494	EXPANDABLE SLEEVING
G-403	RUBBER TARP STRAP
GAM-268-01	PICK-UP TUBE
LPA-169	BOTTLE SUPPORT
SSP-160-01	PUMP MOUNTING ASSY.
SSP-172	SURROUND GUARD
SSP-173	LEFT PUMP GUARD
SSP-174	GUARD ANGLE BRACKET
SSP-176	GUARD WINDOW
SSP-177	RIGHT REAR PUMP GUARD
SSP-178	RIGHT FRONT PUMP GUARD
13424-01	CABLE TIE
17440-00	GROUNDING CLAMP
18245-02	HEAT SHRINK TUBING
18291-01	FLOOR MOUNT MAST
19845-00	LITERATURE KIT
19882-00	SUPPORT MAST CAP
19889-00	MOUNTING ADAPTER
19891-00	PIPE CLAMP
19892-00	COVER PLATE
20188-16C	SCREW
20190-30	CATALYST HOSE
20195-30	MATERIAL HOSE
20368-00	SWIVEL CASTER
20569-01	SPARTAN SUPPORT MAST
20731-04	POLYETHYLENE TUBING
20732-01	POLYETHYLENE TUBING
20732-06	POLYETHYLENE TUBING
20864-06	SPARTAN II PUMP ASSY.
20941-00	CATALYST JUG
20945-00	CATALYST RECIRCULATION ASSY.
21054-01	NYLON TUBING
21203-12	POLYURETHANE TUBING
21654-00	SOLVENT TANK
21658-00	MOUNTING BRACKET
21663-00	GUN MOUNTING BLOCK
21668-01	SPARTAN II GUN ASSY
21670-00	SUPPORT TANK
21674-00	GUIDE HOSE ASSY.
21694-25	MATERIAL HOSE

Part Number	Description
23220-00	CONTROL BOX
23231-00	SPARTAN II DECAL
23241-00	SPARTAN II DECAL
3923-02	SPIRAL WRAP
7486-04	WASHER
7486-05	WASHER
7486-07	WASHER
7486-10	WASHER
7486-13	WASHER
7733-12	HEX NUT
7733-14	HEX NUT
7733-42	HEX NUT
7734-06	LOCK WASHER
7734-07	LOCK WASHER
7734-10	LOCK WASHER
7734-12	LOCK WASHER
7957-32C	SCREW
7957-32F	SCREW
7958-56C	SCREW
8155-160C	SCREW
9704-11	TUBING
9704-83	TUBING
9955-24C	SCREW

Sec3:1

Section 3 - General Information: Sub-Assembly Drawings

23220-00 Control Box Assembly

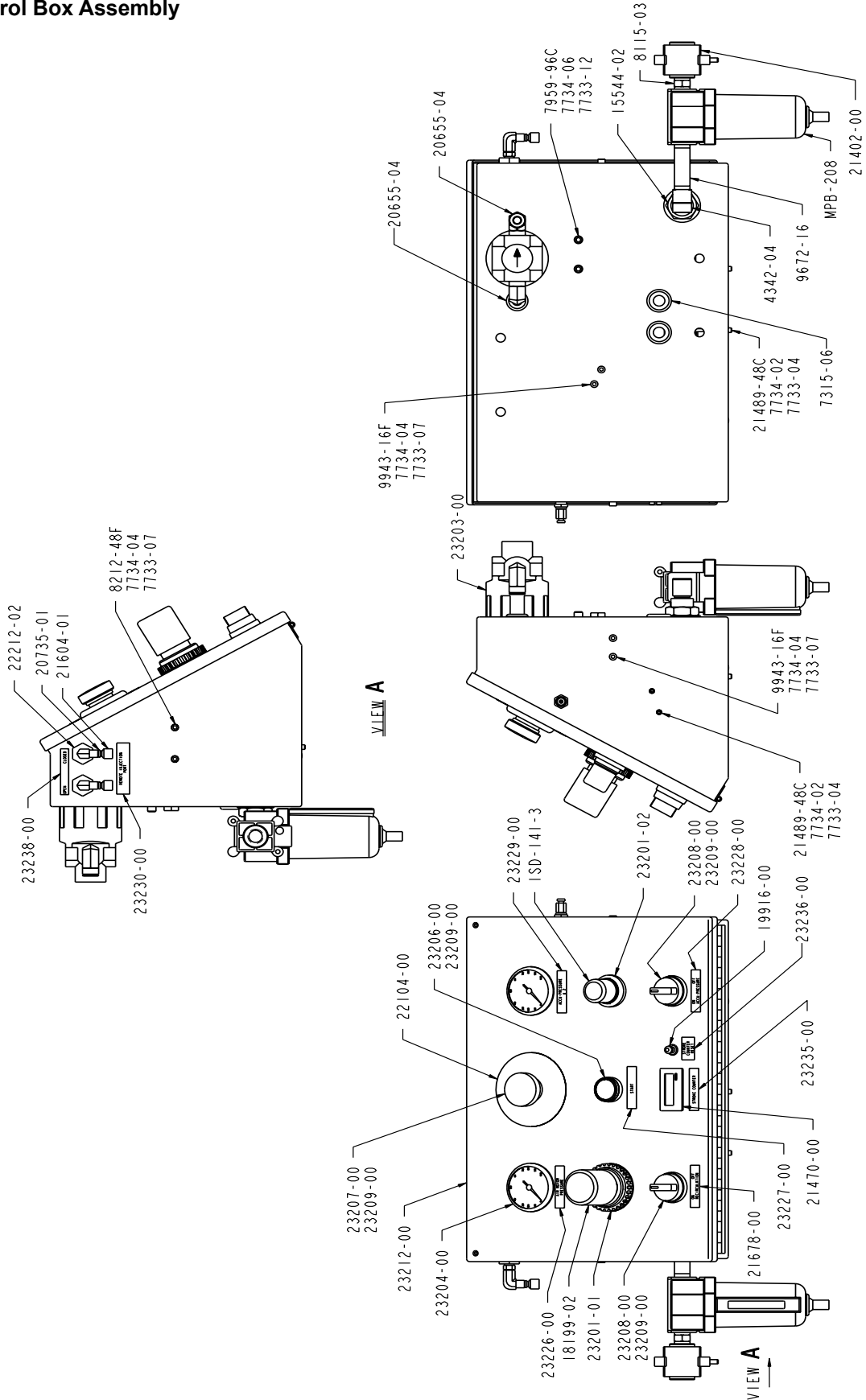

Section 3 - General Information: Sub-Assembly Drawings

23220-00 Control Box Assembly

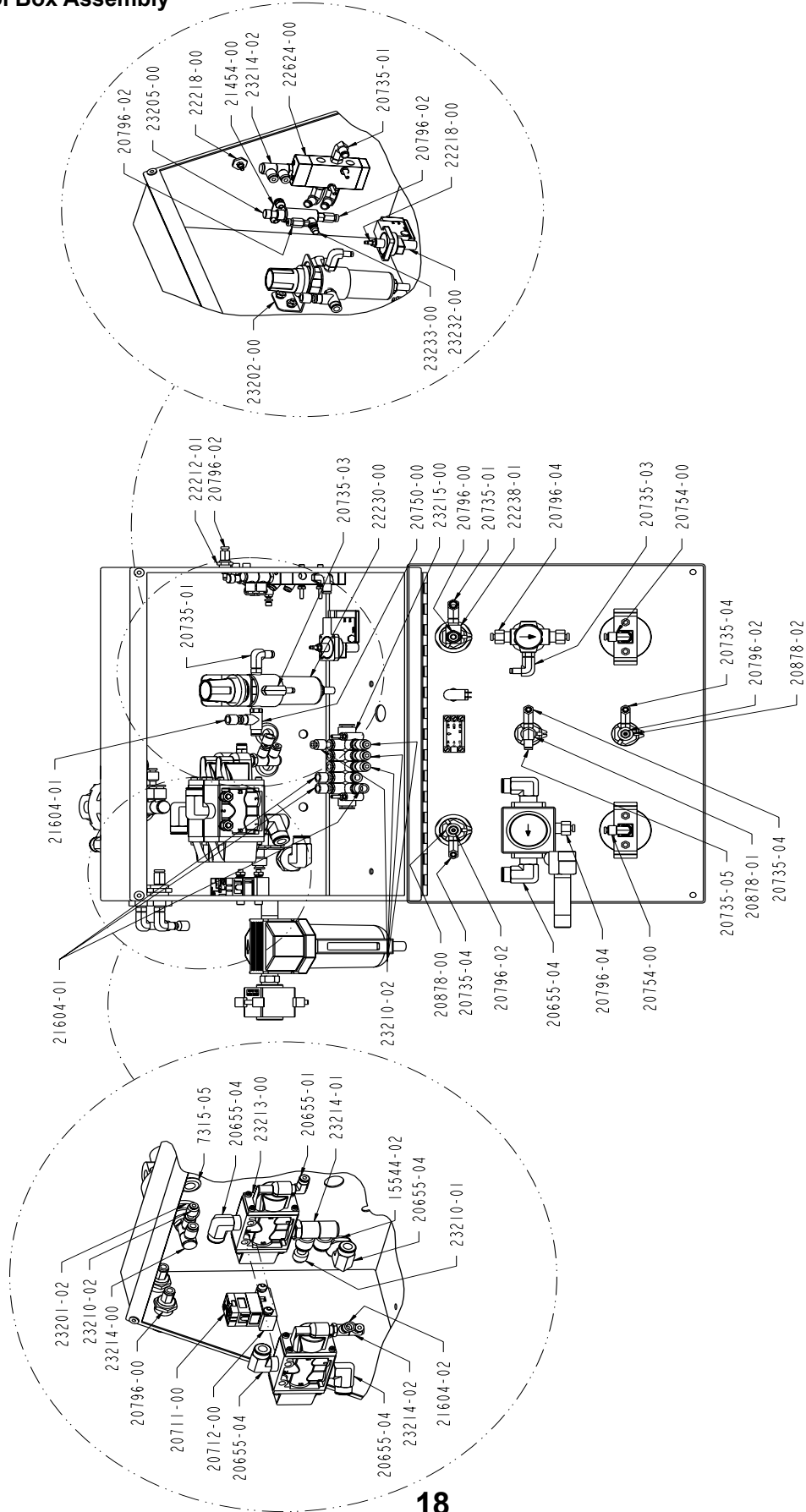

VIEW SHOWN WITH COVER OPEN

Sec3:2

Section 3 - General Information: Sub-Assembly Drawings

23220-00 Control Box Assembly

GLASSCRAFT P/N	SIZE & COLOR	LENGTH
21203-12	5/32" BLUE	10 FEET
21203-02	1/4" YELLOW	7 FEET
21203-14	3/8" BLUE	11 FEET
21203-04	1/4" BLUE	10 FEET
21203-13	5/32" YELLOW	11 FEET

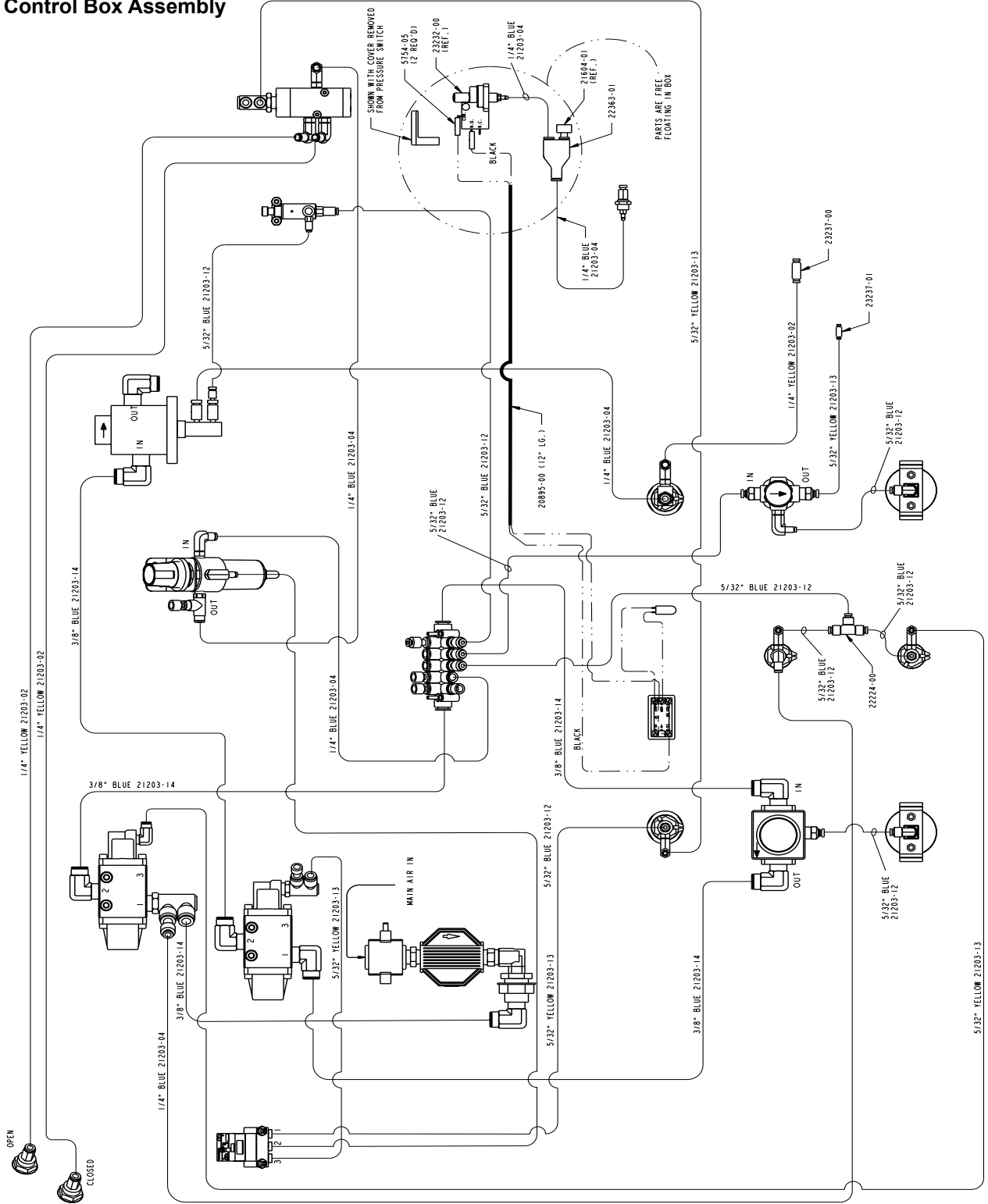

Section 3 - General Information: Sub-Assembly Drawings

23220-00 Control Box Assembly

Part Number	Description
ISD-141-3	MINI REGULATOR
MPB-208	AIR FILTER
15544-02	BULKHEAD FITTING
18199-02	AIR REGULATOR
19916-00	PUSH SWITCH
20655-01	ELBOW FITTING
20655-04	ELBOW FITTING
20711-00	AIR VALVE
20712-00	RELAY SUBPLATE
20735-01	ELBOW FITTING
20735-03	ELBOW FITTING
20735-04	ELBOW FITTING
20735-05	ELBOW FITTING
20750-00	MALE RUN SWIVEL TEE
20754-00	ELBOW FITTING
20796-00	FITTING
20796-02	FITTING
20796-04	FITTING
20878-00	MINIATURE VALVE
20878-01	MINIATURE VALVE
20878-02	MINIATURE VALVE
20895-00	2 COND. CABLE
21203-02	POLYURETHANE TUBING
21203-04	POLYURETHANE TUBING
21203-12	POLYURETHANE TUBING
21203-13	POLYURETHANE TUBING
21203-14	POLYURETHANE TUBING
21402-00	VALVE
21454-00	MOUNTING BRACKET
21470-00	COUNTER
21489-48C	SCREW
21604-01	PLASTIC TUBE PLUG
21604-02	PLASTIC TUBE PLUG
21678-00	RECIRCULATION DECAL
22104-00	EMERGENCY STOP DECAL
22212-01	BULKHEAD FITTING
22212-02	BULKHEAD FITTING
22218-00	FITTING
22224-00	TEE FITTING
22230-00	REGULATOR FILTER
22238-01	POPPET VALVE
22363-01	FITTING
22624-00	SPOOL VALVE
23201-01	PANEL NUT

Part Number	Description
23201-02	PANEL NUT
23202-00	WALL MOUNTED BRACKET
23203-00	REGULATOR
23204-00	PANEL MOUNT GAUGE
23205-00	REGULATOR
23206-00	SPARTAN START BUTTON
23207-00	SPARTAN E-STOP BUTTON
23208-00	SELECTOR SWITCH
23209-00	ADAPTER VALVE
23210-01	TUBE REDUCER
23210-02	TUBE REDUCER
23212-00	SPARTAN II CONTROL BOX
23213-00	SPOOL VALVE
23214-00	FITTING
23214-01	FITTING
23214-02	FITTING
23215-00	AIR MANIFOLD
23226-00	MOTOR PRESSURE DECAL
23227-00	START DECAL
23228-00	ACCU-PRESSURE ON-OFF DECAL
23229-00	ACCU-PRESSURE DECAL
23230-00	REMOTE INJECTION DECAL
23232-00	PRESSURE SWITCH
23233-00	NEEDLE VALVE
23235-00	STROKE COUNTER DECAL
23236-00	STROKE COUNTER DECAL
23237-00	FITTING
23237-01	FITTING
23238-00	OPEN/CLOSED DECAL
4342-04	ELBOW FITTING
5754-05	TERMINAL LUG
7315-05	RUBBER GROMMET
7315-06	RUBBER GROMMET
7733-04	HEX NUT
7733-07	HEX NUT
7733-12	HEX NUT
7734-02	LOCK WASHER
7734-04	LOCK WASHER
7734-06	LOCK WASHER
7959-96C	SCREW
8115-03	FITTING
8212-48F	SCREW
9672-16	FITTING
9943-16F	SCREW

Sec3:2

Section 3 - General Information: Sub-Assembly Drawings

21668-01 Gun Assembly

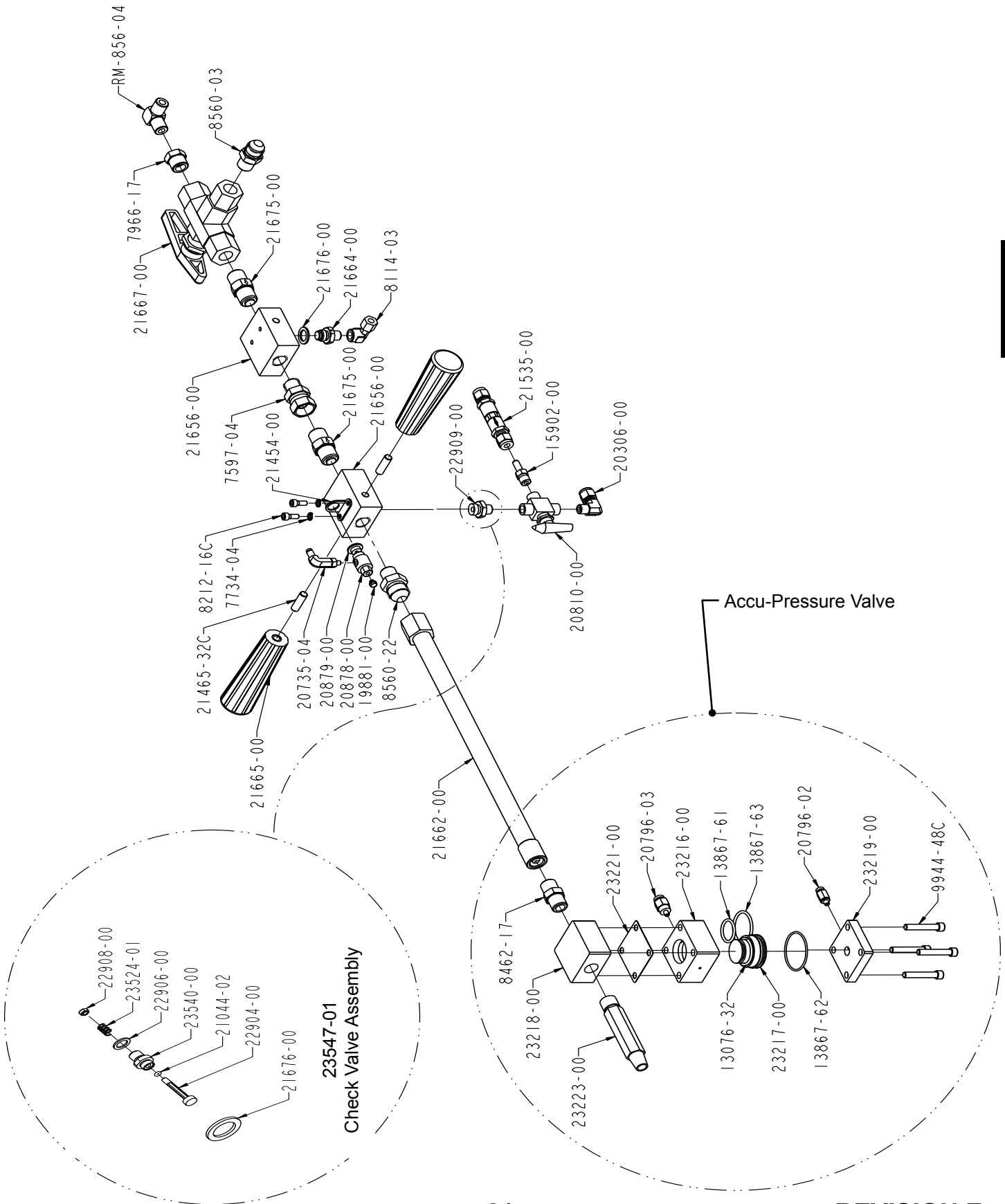

Section 3 - General Information: Sub-Assembly Drawings

21668-01 Gun Assembly

Part Number	Description	Qty.
RM-856-04	ELBOW FITTING	1
13076-32	O-RING	1
13867-61	O-RING	1
13867-62	O-RING	1
13867-63	O-RING	1
15902-00	FITTING	1
19881-00	FITTING	1
20306-00	ELBOW FITTING	1
20735-04	ELBOW FITTING	1
20796-02	FITTING	1
20796-03	FITTING	1
20810-00	BALL VALVE	1
20878-00	VALVE	1
20879-00	PUSH BUTTON	1
21044-02	O-RING	1
21454-00	MOUNTING BRACKET	1
21465-32C	STUD	2
21535-00	CHECK VALVE	1
21656-00	GUN BLOCK	2
21662-00	INJECTION WAND	1
21664-00	CHECK VALVE	1
21665-00	GUN HANDLE	2
21667-00	BALL VALVE	1
21675-00	CHECK VALVE	2
21676-00	CRUSH WASHER	2
22904-00	CHECK VALVE STEM	1
22906-00	CRUSH WASHER	1
22908-00	NUT	1
22909-00	CHECK VALVE BODY	1
23216-00	MPS BLOCK	1
23217-00	PRESSURE SENSOR PISTON	1
23218-00	BOTTOM PLATE	1
23219-00	TOP PLATE	1
23221-00	GASKET	1
23223-00	INJECTION PORT	1
23524-01	SPRING	1
23540-00	CHECK VALVE BODY	1

Part Number	Description	Qty.
7597-04	SWIVEL FITTING	1
7734-04	LOCK WASHER	2
7966-17	FITTING	1
8114-03	ELBOW FITTING	1
8212-16C	SCREW	2
8462-17	FITTING	1
8560-03	FITTING	1
8560-22	FITTING	1
9944-48C	SCREW	4

Sec3:2

Section 3 - General Information: Sub-Assembly Drawings

23547-01 Check Valve Assembly

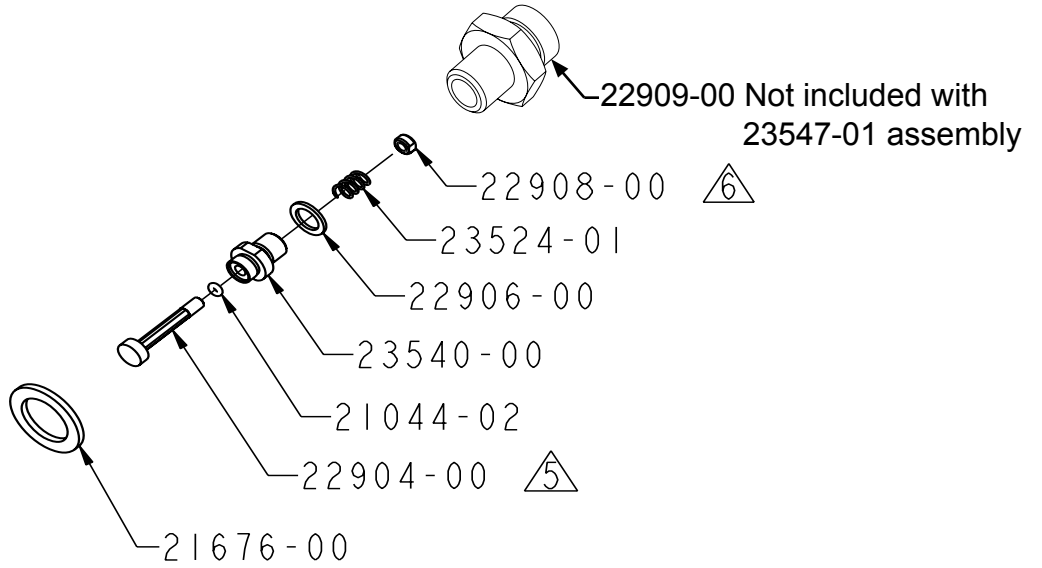

6 TIGHTEN NUT TO SHOW 1/2 TO 1 THREAD.
5 USE PURPLE LOCTITE 222 ON THREADS.

Sec3:2

21664-00 Solvent/Air Purge Check Valve Assembly	21675-00 Resin Check Valve Assembly
--	--

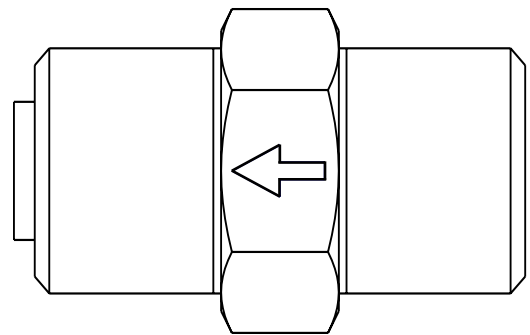
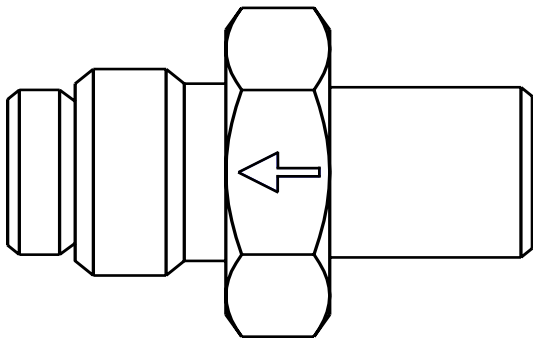

Section 3 - General Information: Sub-Assembly Drawings

GAM-268-01 Material Pick-Up Kit

Sec3:2

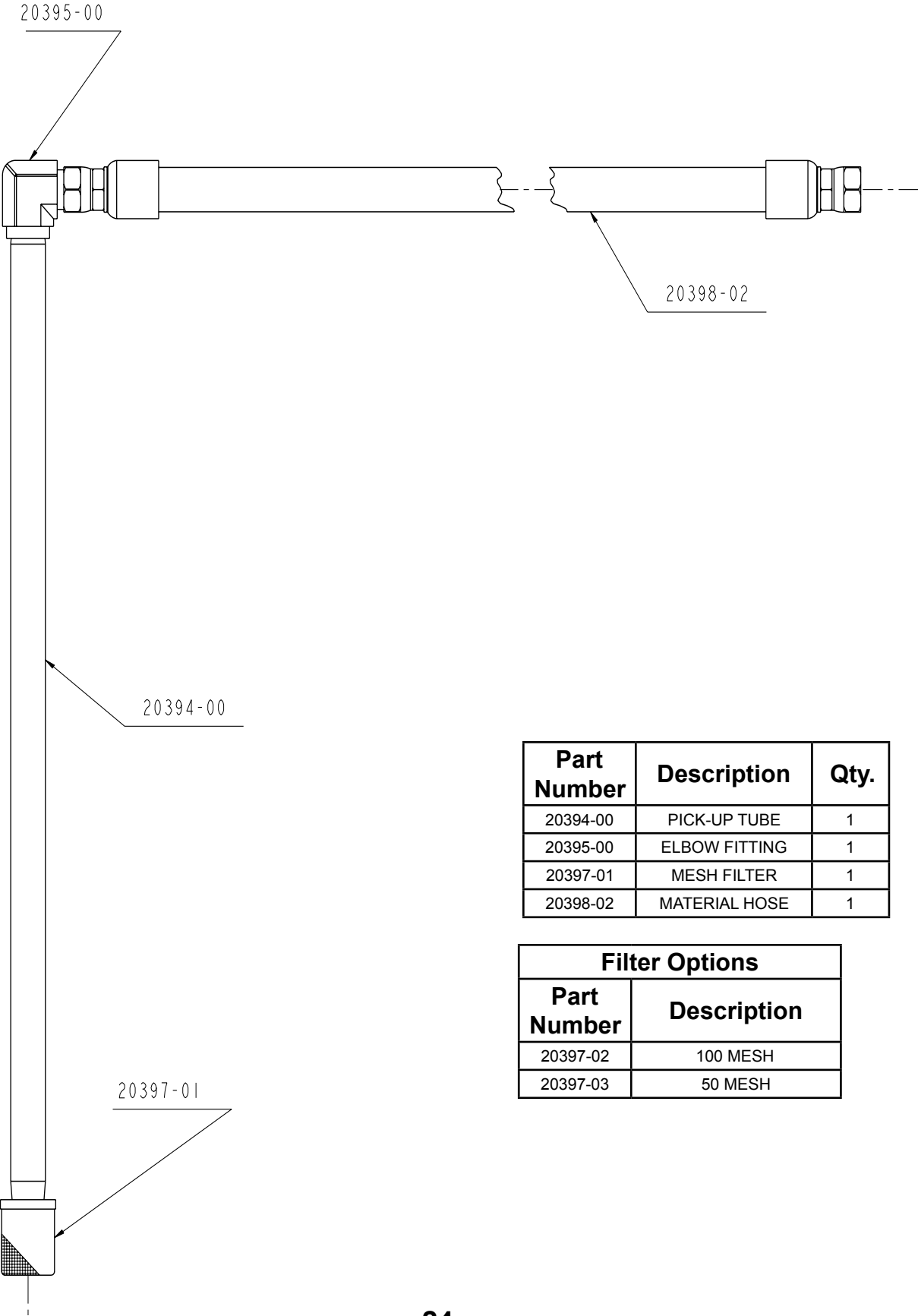

Part Number	Description	Qty.
20394-00	PICK-UP TUBE	1
20395-00	ELBOW FITTING	1
20397-01	MESH FILTER	1
20398-02	MATERIAL HOSE	1

Filter Options	
Part Number	Description
20397-02	100 MESH
20397-03	50 MESH

Section 3 - General Information: Sub-Assembly Drawings

20941-00 Catalyst Bottle Assembly

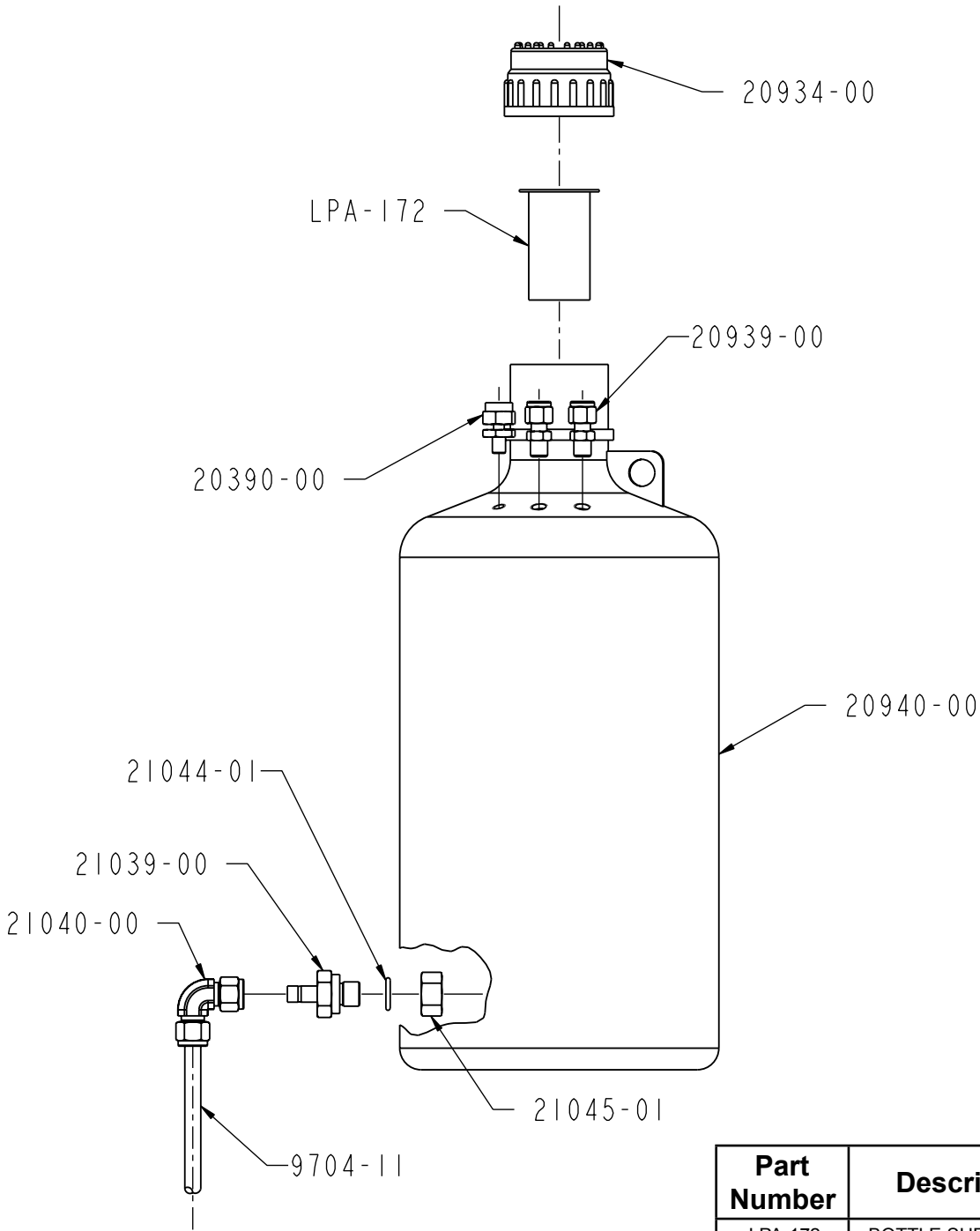

Sec3:2

Part Number	Description	Qty.
LPA-172	BOTTLE SUPPLY FILTER	1
20390-00	FITTING	1
20934-00	JUG CAP	1
20939-00	MALE CONNECTOR	2
20940-00	SUPPLY BOTTLE	1
21039-00	FITTING	1
21040-00	ELBOW FITTING	1
21045-01	HEX NUT	1
9704-11	TUBING	5

Section 3 - General Information: Sub-Assembly Drawings

21654-00 Solvent Tank Assembly

Sec3:2

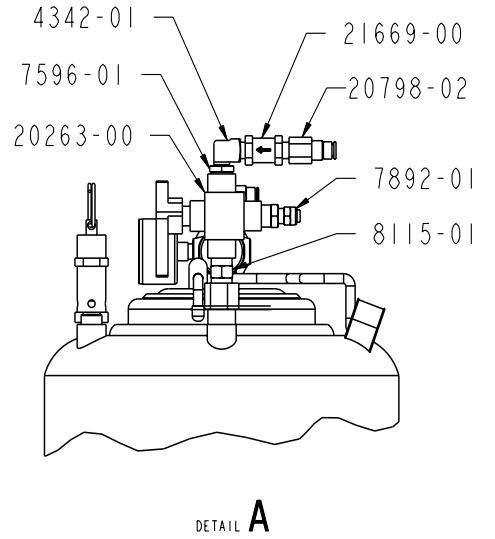
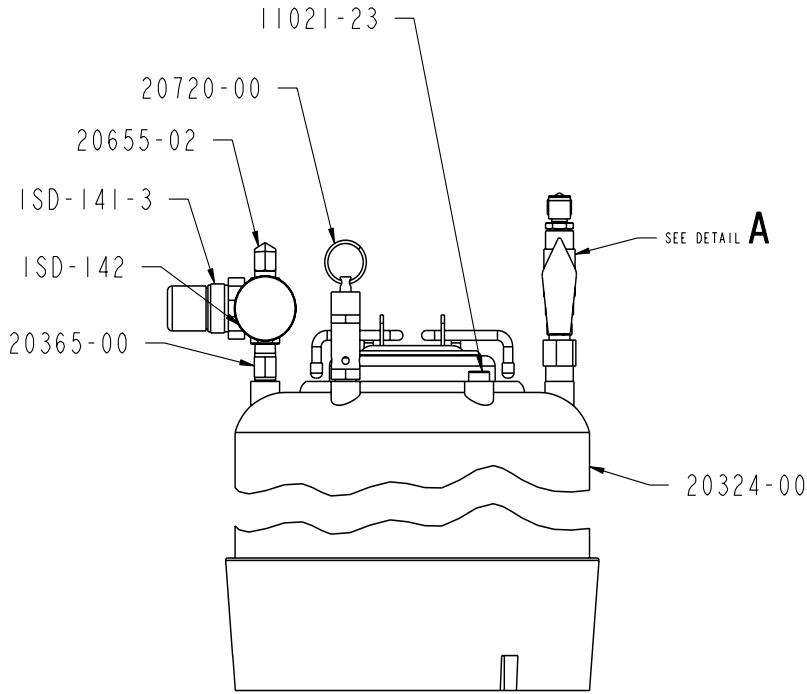

Part Number	Description	Qty.
ISD-141-3	MINI REGULATOR	1
ISD-142	SOLVENT POT GAUGE	1
11021-23	PIPE PLUG	1
20263-00	VALVE	1
20324-00	SOLVENT TANK	1
20365-00	VALVE	1
20655-02	ELBOW FITTING	1
20720-00	VALVE	1
20798-02	FITTING	1
21669-00	CHECK VALVE	1
4342-01	ELBOW FITTING	1
7596-01	FITTING	1
7892-01	FITTING	1
8115-01	FITTING	1

Section 3 - General Information: Maintenance

Maintenance

It is recommended that the following service be performed on a weekly basis.

1. Inspect and lubricate Catalyst Slave Pump Linkage. (See Catalyst Slave Pump User Manual.)
2. Inspect Pump Shafts on Material and Catalyst Pumps, making certain they are clean and free of foreign material. Clean and lubricate as required.

For long term storage of your injection system, it is recommended that the following procedures be followed:

1. Place dry nitrogen in the material drums and secure drum.
2. Make certain all air and material valves are in their "OFF" position.



GlasCraft recommends that you contact your gel-coat and/or resin supplier concerning material pot-life during extended periods of shut-down. The decision as to whether or not to leave material in your system should be based on information from your material suppliers as well as GlasCraft.

Consult your local authorized GlasCraft distributor for more information concerning system storage.

Section 3 - General Information: Troubleshooting

Troubleshooting



Before altering catalyst percentage by moving the catalyst pump to a new desired location on the ratio arm ALWAYS ensure that the catalyst recirculation valve is turned to the recirculation position, and the air pressure is removed from the system.

It is absolutely essential that both streams of material are pumped to the head without air or gas entrapped. For example, if air is drawn into the resin stream through the resin pump inlet system, i.e., via bad connection or filter end coming out of resin surface, then this air if not purged out of the machine by recirculating on by-pass will naturally go to the head through the mixer and into the RTM mold. This fault condition will manifest itself in the molded part having very small bubbles; almost in a froth like state, on the upper side of the molded part once the mold is opened. The reason for these bubbles being so small is due to the fact that air coming through the mixer with the resin is mixed and frothed before finally entering the mold.

Air or gas in the catalyst stream, leads to a different type of fault in the molded part. This condition will be manifest by observing when opening the mold after injection and supposed cure, that there are wet patches of uncured or semi-gelled resin in the molded part. The causes attributed to this are:

1. Air is drawn in by the catalyst pump through a bad connection on the inlet stream from the catalyst container or pump inlet connection.
2. Catalyst contamination in the pump system causing oxidation resulting in peroxide gas bubbles being generated within the supposedly hydraulic sealed system of the catalyst.
3. The catalyst pump has faulty seals or is contaminated with particles.

To ensure that the catalyst system is totally hydraulically tight, it is expedient after a period of shut-down that the procedures in the instructions for commissioning the catalyst stream should be repeated.

Section 3 - General Information: Options

23240-00 Spartan II Auto (DELUXE)

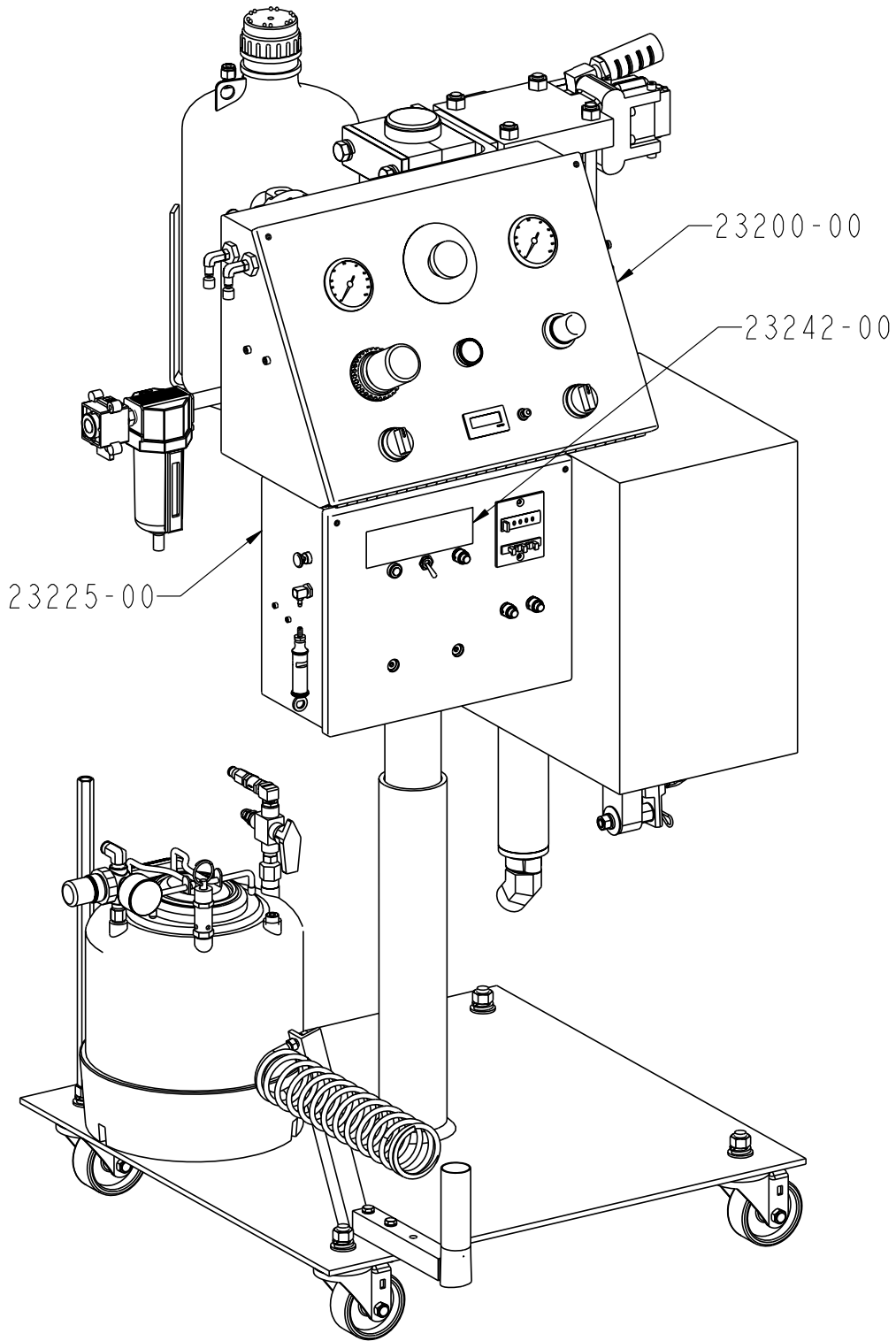

Section 3 - General Information: Options

23225-00 Spartan II Modules

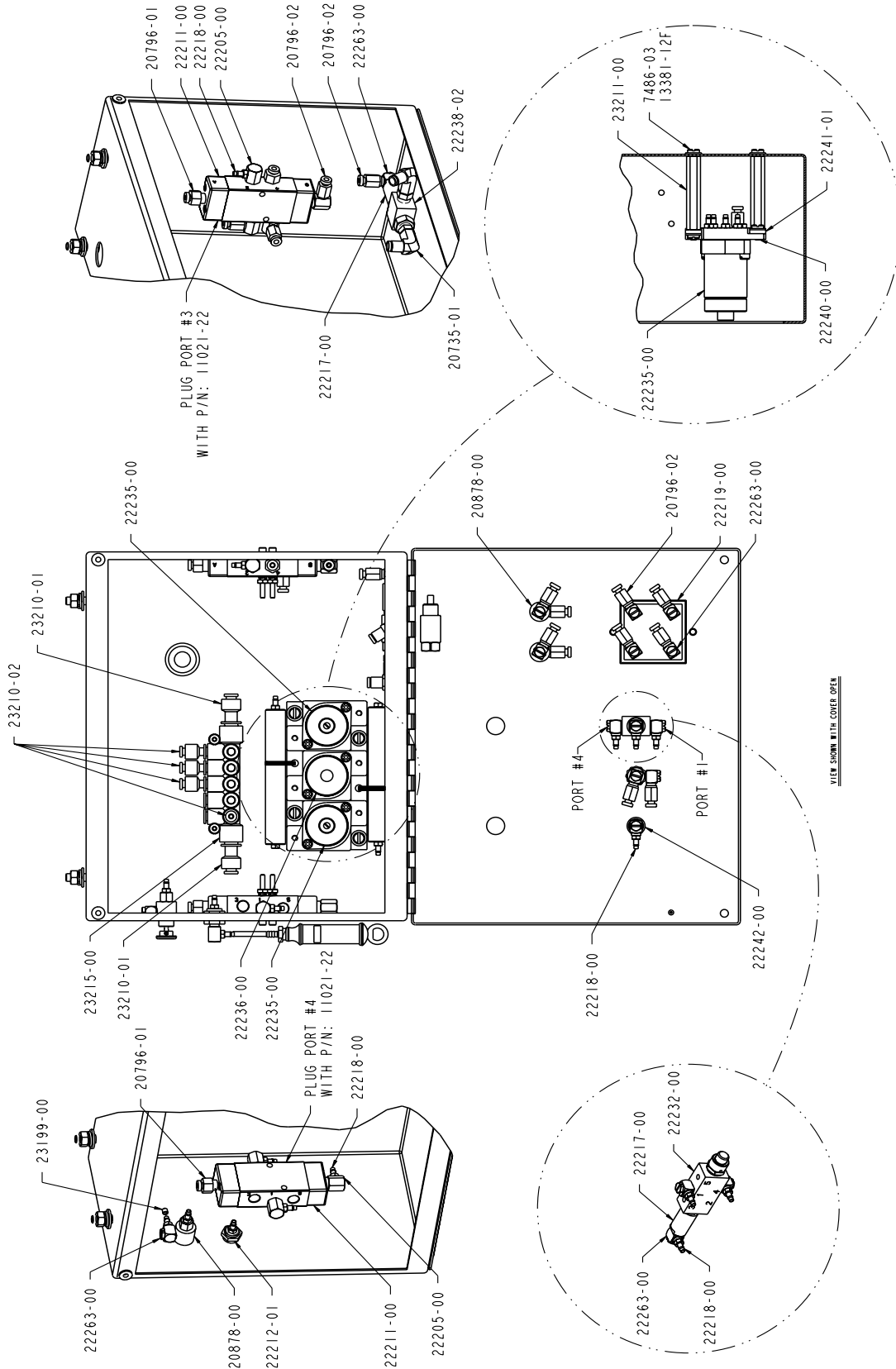

Sec3:5

Section 3 - General Information: Options

23225-00 Spartan II Modules

Part Number	Description	Qty.
10080-03	FITTING	1
11021-22	PIPE PLUG	2
13381-12F	SCREW	14
13424-01	CABLE TIE	3
20735-01	ELBOW FITTING	2
20796-01	FITTING	3
20796-02	FITTING	24
20878-00	MINIATURE VALVE	3
20879-00	PUSH BUTTON	1
21203-01	POLYURETHANE TUBING	AN
21203-04	POLYURETHANE TUBING	9
21203-05	POLYURETHANE TUBING	12
21203-10	POLYURETHANE TUBING	5
21203-11	POLYURETHANE TUBING	7
21203-12	POLYURETHANE TUBING	12
21203-13	POLYURETHANE TUBING	3
21203-15	POLYURETHANE TUBING	3
21489-48C	SCREW	6
21660-00	VALVE	1
22205-00	FITTING	7
22207-00	FITTING	3
22211-00	SPOOL VALVE	2
22212-01	BULKHEAD FITTING	1
22213-01	RED PUSH BUTTON	1
22213-02	BLACK PUSH BUTTON	1
22213-03	BLACK PUSH BUTTON	1
22214-00	FITTING	4
22216-00	SHUTTLE VALVE	3
22217-00	PILOT ACTUATOR	2
22218-00	FITTING	24
22219-00	PREDETERMINING COUNTER	1
22222-00	DECAL, INJ EMERGENCY, AC	1
22224-00	FTG, TEE, TUBE, PUSH-IN, 5	1

Part Number	Description	Qty.
22232-00	SPOOL VALVE	1
22234-00	INLINE VOLUME CHAMBER	2
22235-00	DELAY VALVE	2
22236-00	VALVE	1
22238-02	POPPET VALVE	1
22239-00	FITTING	1
22240-00	VALVE PLATE	3
22241-01	VALVE MOUNTING BRACKET	2
22242-00	PRESSURE INDICATOR	1
22244-05F	SCREW	8
22247-00	GEL TIMER DECAL	1
22248-00	ADJUSTMENT DECAL	1
22249-00	AIR PURGE DECAL	1
22251-00	SOLVENT FLUSH DECAL	1
22252-00	SOLVENT ADJUSTMENT DECAL	1
22263-00	ADJUSTABLE "L" FITTING	14
22267-00	METROPLITAN WHISTLE	1
23199-00	SIGNAL DELAY	1
23210-01	TUBE REDUCER	2
23210-02	TUBE REDUCER	4
23211-00	HEX STANDOFF	4
23215-00	AIR MANIFOLD	1
23224-00	CONTROL BOX	1
7315-06	RUBBER GROMMET	1
7486-03	WASHER	14
7486-13	WASHER	8
7733-04	HEX NUT	6
7733-12	HEX NUT	4
7734-02	LOCK WASHER	6
7734-06	WASHER, LOCK, SPRING, 1/4	4
9944-24C	SCREW, SHDC, AS, .250-20X	4

AN = AS NEEDED

Section 4 - Safety Information: General Safety

Operating Your Polyester System Safely

1.0 Introduction

Any tool, if used improperly, can be dangerous. Safety is ultimately the responsibility of those using the tool. In like manner, safe operation of polyester processes is the responsibility of those who use such processes and those who operate the equipment. This manual outlines procedures to be followed in conducting polyester operations safely.

This system has been specifically designed for use of Polyester Resin, Gel-Coat, and Methyl Ethyl Ketone Peroxides (MEKP) applications. Other formulations or blends considered for use in this equipment is strictly prohibited without the expressed consent by GlasCraft Inc.

GlasCraft, Inc. cannot eliminate every danger nor foresee every circumstance that might cause an injury during equipment operation. Some risks, such as the high pressure liquid stream that exits the spray tip, are inherent to the nature of the machine operation and are necessary to the process in order to manufacture the end-product. For this reason, ALL personnel involved in polyester operations should read and understand the Safety Manual. It is very important for the safety of employees involved in the operation that equipment operators, maintenance and supervisory personnel understand the requirements for safe operation.

Each user should examine his own operation, develop his own safety program and be assured that his equipment operators follow correct procedures. GlasCraft hopes that this manual is helpful to the user and recommends that the precautions in this manual be included in any such program. GlasCraft recommends this Safety Manual remain on your equipment at all times for your personnel safety.

In addition to the manual, GlasCraft recommends that the user consult the regulations established under the Occupational Safety & Health Act (OSHA), particularly the following sections:

- 1910.94 Pertaining to ventilation.
- 1910.106 Pertaining to flammable liquids.
- 1910.107 Pertaining to spray finishing operations,

particularly Paragraph (m) Organic Peroxides and Dual Component Coatings.

Other standards and recognized authorities to consult are the National Fire Protection Association (NFPA) bulletins as follows:

- NFPA No. 33 Chapter 14, Organic Peroxides and Dual Component Materials
- NFPA No. 63 Dust Explosion Prevention
- NFPA No. 70 National Electrical Code
- NFPA No. 77 Static Electricity
- NFPA No. 91 Blower and Exhaust System
- NFPA No. 654 Plastics Industry Dust Hazards
- Type of Fire Extinguishing equipment recommended :

Fire Extinguisher -- code ABC, rating number 4a60bc. Extinguishing Media -- Foam, Carbon Dioxide, Dry Chemical, Water Fog.

Copies of the above bulletins are available, at a nominal charge from:

National Fire Protection Association
470 Atlantic Avenue
Boston, MA 02210

Research Report No. 11 of the American Insurance Association deals with "Fire, Explosion and Health Hazards of Organic Peroxides". It is published by...

American Insurance Association
85 John Street
New York, New York 10038

Local codes and authorities also have standards to be followed in the operation of your spraying equipment. Your insurance carrier will be helpful in answering questions that arise in your development of safe procedures.

1.2 Personnel Safety Equipment

GlasCraft recommends the following Personal Safety Equipment for conducting safe operations of the Polyester Systems:



Section 4 - Safety Information: General Safety

GlasCraft recommends that the user consult the state and local regulations established for all Safety equipment listed.

2.0 Material Safety

2.1 Hazards Associated with Laminating Operations

The major hazards which should be guarded against in polyester laminating operations are those associated with:

1. The flammability and explosion dangers of the catalyst normally used - Methyl Ethyl Ketone Peroxide (MEKP).
2. The flammability dangers of clean-up solvents sometimes used (GlasCraft recommends that clean-up solvents be nonflammable), and of resin diluents used, such as styrene.
3. The flammability dangers of catalyst diluents, if used. (GlasCraft recommends that catalyst not be diluted.)
4. The flammability dangers of the uncured liquid resins used.
5. The combustibility dangers of the cured laminate, accumulations of overspray, and laminate sandings.
6. The toxicity dangers of all the chemicals used in laminating operations with respect to ingestion, inhalation and skin and eye hazards.

2.2 Catalyst

(Methyl Ethyl Ketone Peroxide)

MEKP is among the more hazardous materials found in commercial channels. The safe handling of the "unstable (reactive)" chemicals presents a definite challenge to the plastics industry. The highly reactive property which makes MEKP valuable to the plastics industry in producing the curing reaction of polyester resins also produces the hazards which require great care and caution in its storage, transportation, handling, processing and disposal.

MEKP is not a single chemical. Various polymeric forms may exist which are more or less hazardous with respect to each other. These differences may arise not only from different molecular structures (all are, nevertheless, called "MEKP") and from possible trace impurities left from the manufacture of the chemicals, but may also arise by contamination of the MEKP with other materials in its

storage or use. Even a small amount of contamination with acetone, for instance, may produce an extremely shock-sensitive and explosive compound.

Contamination with promoters, or materials containing promoters, such as laminate sandings, or with any readily oxidizable material, such as brass or iron, will cause exothermic "redox" reactions which can become explosive in nature. Heat applied to MEKP, or heat build-up from contamination reactions can cause it to reach what is called its Self-Accelerating Decomposition Temperature (SADT).

Researchers have reported measuring pressure rates-of-rise well in excess of 100,000 psi per second when certain MEKP's reach their SADT. (For comparison, the highest pressure rate-of-rise listed in NFPA Bulletin No. 68, "Explosion Venting", is 12,000 psi per second for an explosion of 12% acetylene and air. The maximum value listed for a hydrogen explosion is 10,000 psi per second.)

Some forms of MEKP, if allowed to reach their SADT, will burst even an open topped container. This suggests that it is not possible to design a relief valve to vent this order of magnitude of pressure rate-of-rise. The user should be aware that any closed container, be it a pressure vessel, surge chamber, or pressure accumulator, could explode under certain conditions. There is no engineering substitute for care by the user in handling organic peroxide catalysts.

If, at any time, the pressure relieve valve on top of the catalyst tank should vent, the area should be evacuated at once and the fire department called. The venting could be the first indication of a heat, and therefore, pressure build-up that could eventually lead to an explosion. Moreover, if a catalyst tank is sufficiently full when the pressure relief valve vents, some catalyst may spray out, which could cause eye injury. For this reason, and many others, anyone whose job puts them in an area where this vented spray might go, should always wear full eye protection even when laminating operations are not taking place.

Section 4 - Safety Information: General Safety

Safety in handling MEKP depends to a great extent on employee education, proper safety instructions and safe use of the chemicals and equipment. Workers should be thoroughly informed of the hazards that may result from improper handling of MEKP, especially in regards to contamination, heat, friction and impact. They should be thoroughly instructed regarding the proper action to be taken in the storage, use and disposal of MEKP and other hazardous materials used in the laminating operation.

In addition, users should make every effort to:

1. Store MEKP in a cool, dry place in original containers away from direct sunlight and away from other chemicals.
2. Keep MEKP away from heat, sparks and open flames.
3. Prevent contamination of MEKP with other materials, including polyester overspray and sandings, polymerization accelerators and promoters, brass, aluminum and non-stainless steels.
4. Never add MEKP to anything that is hot, since explosive decomposition may result.
5. Avoid contact with skin, eyes and clothing. Protective equipment should be worn at all times. During clean-up of spilled MEKP, personal safety equipment, gloves and eye protection must be worn. Fire fighting equipment should be at hand and ready.
6. Avoid spillage, which can heat up to the point of self-ignition.
7. Repair any leaks discovered in the catalyst system immediately, and clean up the leaked catalyst at once in accordance with the catalyst manufacturer's instructions.
8. Use only original equipment or equivalent parts from GlasCraft in the catalyst system (i.e.: hoses, fittings, etc.) because a dangerous chemical reaction may result between substituted parts and MEKP.
9. Catalyst accumulated from the purging of hoses or the measurement of fluid output deliveries should never be returned to the supply tank. such catalyst should be diluted

with copious quantities of clean water and disposed of in accordance with the catalyst manufacturer's instructions.

The extent to which the user is successful in accomplishing these ends and any additional recommendations by the catalyst manufacturer determines largely the safety that will be present in his operation.

2.3 Clean-Up Solvents and Resin Diluents

WARNING

A hazardous situation may be present in your pressurized fluid system!

Hydrocarbon Solvents can cause an explosion when used with aluminum or galvanized components in a closed (pressurized) fluid system (pumps, heaters, filters, valves, spray guns, tanks, etc.)

The explosion could cause serious injury, death and/or substantial property damage.

Cleaning agents, coatings, paints, etc. may contain Halogenated Hydrocarbon Solvents.

Some GlasCraft spray equipment includes aluminum or galvanized components and will be affected by Halogenated Hydrocarbon Solvents.

There are three key elements to the Halogenated Hydrocarbon (HHC) solvent hazard.

1. **The presence of HHC solvents.** 1,1,1-Trichloroethane and Methylene Chloride are the most common of these solvents. However, other HHC solvents are suspect if used; either as part of paint or adhesives formulation, or for clean-up flushing.
2. **Aluminum or Galvanized Parts.** Most handling equipment contains these elements. In contact with these metals, HHC solvents could generate a corrosive reaction of a catalytic nature.
3. **Equipment capable of withstanding pressure.** When HHC solvents contact aluminum or galvanized parts inside a closed container such as a pump, spray gun, or fluid handling system, the chemical reaction can, over time, result in a build-up of heat and pressure, which can reach explosive proportions. When all three elements are present, the result can be an extremely violent explosion. the reaction can be sustained with very little aluminum or galvanized metal; **any amount of aluminum is too much.**

Section 4 - Safety Information: General Safety

The reaction is unpredictable. Prior use of an HHC solvent without incident (corrosion or explosion) does NOT mean that such use is safe. These solvents can be dangerous alone (as a clean-up or flushing agent) or when used as a component or a coating material. There is no known inhibitor that is effective under all circumstances. Furthermore, the mixing of HHC solvents with other

materials or solvents, such as MEK, alcohol, and toluene, may render the inhibitors ineffective.

The use of reclaimed solvents is particularly hazardous. Reclaimers may not add any inhibitors. Also, the possible presence of water in reclaimed solvents could feed the reaction.

Anodized or other oxide coatings cannot be relied upon to prevent the explosive reaction. Such coatings can be worn, cracked, scratched, or too thin to prevent contact. There is no known way to make oxide coatings or to employ aluminum alloys which will safely prevent the chemical reaction under all circumstances.

Several solvent suppliers have recently begun promoting HHC solvents for use in coating systems. The increasing use of HHC solvents is increasing the risk. Because of their exemption from many State Implementation Plans as Volatile Organic Compounds (VOC's), their low flammability hazard, and their not being classified as toxic or carcinogenic substances, HHC solvents are very desirable in many respects.

WARNING

Do not use Halogenated Hydrocarbon solvents in pressurized fluid systems having aluminum or galvanized wetted parts.



GlasCraft is aware of NO stabilizers available to prevent Halogenated Hydrocarbon solvents from reaction under all conditions with aluminum components in a closed fluid system.

TAKE IMMEDIATE ACTION...

Halogenated Hydrocarbon solvents are dangerous when used with aluminum components in a closed fluid system.

Consult your material supplier to determine whether your solvent or coating contains Halogenated Hydrocarbon Solvents.

GlasCraft recommends that you contact your solvent

supplier regarding the best non-flammable clean-up solvent with the heat toxicity for your application.

If, however, you find it necessary to use flammable solvents, they must be kept in approved, electrically grounded containers.

Bulk solvent should be stored in a well-ventilated, separate building, 50 feet away from your main plant.

You should allow only enough solvent for one day's use in your laminating area.

"NO SMOKING" signs must be posted and observed in all areas of storage or where solvents and other flammable materials are used.

Adequate ventilation (as covered in OSHA Section 1910.94 and NFPA No. 91) is important wherever solvents are stored or used, to minimize, confine and exhaust the solvent vapors.

Solvents should be handled in accordance with OSHA Section 1910.106 and 1910.107.

2.4 Catalyst Diluents

GlasCraft spray-up and gel-coat systems currently produced are designed so that catalyst diluents are not required. GlasCraft, therefore, recommends that diluents not be used. This avoids the possible contamination which could lead to an explosion due to the handling and mixing of MEKP and diluent. In addition, it eliminates any problems from the diluent being contaminated through rust particles in drums, poor quality control on the part of the diluent supplier, or any other reason. If, however, diluents are absolutely required, contact your catalyst supplier and follow his instructions explicitly. Preferably, the supplier should premix the catalyst to prevent possible "on the job" contamination while mixing.

WARNING

If diluents are not used, it should be remembered that catalyst spillage, gun, hose and packing leaks are potentially more hazardous, since each drop contains a higher concentration of catalyst, and therefore will react quicker with overspray and the like.

2.5 Uncured Liquid Resin

Resin should be stored in a well ventilated building at least 50 feet from your main plant. In addition, the storage temperature should not exceed 75 degrees F.

Section 4 - Safety Information: General Safety

In your main plant, store only enough resin for one day's production.

"NO SMOKING" signs must be posted and observed in all areas where resin is stored and/or used.

Refer to OSHA Section 1910.94, 1910.106, 1910.107 and consult resin suppliers for more detailed information.

Adequate ventilation (as covered in OSHA Section 1910.94 and NFPA No. 91) is important wherever solvents are stored or used, to minimize, confine and exhaust the solvent vapors.

Resin must never be stored in an area where MEKP is stored or used.

Open-top drums should not be used, due to possible contamination and possible catalyzation from overspray or spillage of MEKP into drum, which could not only severely damage the polyester spray system, but might also cause the drum of resin to ignite.

When spraying test patterns or purging the gun, always remove the test samples and waste from the building immediately and dispose of them in accordance with your material supplier's recommendations.

2.6 Cured Laminate, Overspray and Laminate Sandings Accumulation

Remove all accumulations of overspray, FRP sandings, etc. from the building as they occur. If this waste is allowed to build up, spillage of catalyst is more likely to start a fire. In addition, the fire would burn hotter and longer.

Floor coverings, if used, should be non-combustible.

Spilled or leaked catalyst may cause a fire if it comes in contact with an FRP product, oversprayed chop or resin, FRP sandings or any other material with MEKP.

To prevent this spillage and leakage, you should:

1. Maintain your GlasCraft System. Check the gun several times daily for catalyst and resin packing or valve leaks. REPAIR ALL LEAKS IMMEDIATELY.
2. Never leave the gun hanging over, or lying inside the mold. A catalyst leak in this situation would certainly damage the part, possibly the mold, and may cause a fire.

3. Inspect resin and catalyst hoses daily for wear or stress at the entry and exits of the boom sections and at the gun and fittings. Replace if wear or weakness is evident or suspected.
4. Arrange the hoses and fiberglass roving guides so that the fiberglass strands DO NOT rub against any of the hoses at any point. If allowed to rub, the hoses may be cut through, causing a hazardous leakage of material which could increase the danger of fire. Also the material may spew onto personnel in the area.

2.7 Toxicity of Chemicals

GlasCraft recommends that you consult OSHA Sections 1910.94, 1910.106, 1910.107 and NFPA No. 33, Chapter 14, and NFPA No. 91.

Contact your chemical supplier(s) and determine the toxicity of the various chemicals used, as well as the best methods to prevent injury, irritation and danger to personnel.

Also determine the best methods of first aid treatment for each chemical used in your plant.

2.8 Treatment of Chemical Injuries

Great care should be used in handling the chemicals (resins, catalyst and solvents) used in polyester systems. Such chemicals should be treated as if they hurt your skin and eyes and as if they are poison to your body. For this reason, GlasCraft recommends the use of protective clothing and eye wear in using polyester systems.

However, users should be prepared in the event of such an injury. Precautions include:

1. Know precisely what chemicals you are using and obtain information from your chemical supplier on what to do in the event the chemical gets onto your skin or into the eyes, or is swallowed.
2. Keep this information together and easily available so that it may be used by those administering first aid or treating the injured person.
3. Be sure the information from your chemical supplier includes instructions on how to treat any toxic effects the chemicals may have.

Section 4 - Safety Information: General Safety

WARNING

Contact a doctor immediately in the event of any injury and give him the information you have collected. If your information includes first aid instructions, administer first aid immediately while you are contacting the doctor.

Fast treatment of the outer skin and eyes that contact such chemicals generally includes immediate and thorough washing of the exposed skin and immediate and continuous flushing of the eyes with lots of clean water for at least 15 minutes or more. These general instructions of first aid treatment, however, may be incorrect for some chemicals; that is why you must know the chemicals and treatment before an accident occurs. Treatment for swallowing a chemical frequently depends upon the nature of the chemical.



Refer to your System User Manual for complete and detailed operating instructions and service information.

3.0 Equipment Safety

WARNING

GlasCraft suggest that personnel safety equipment such as EYE GOGGLES, GLOVES, EAR PROTECTION, and RESPIRATORS be worn when servicing or operating this equipment. Ear protection should be worn when operating a fiberglass chopper to protect against hearing loss since noise levels can be as high as 116 dB (decibels).

This equipment should only be operated or serviced by technically trained personnel!!!

WARNING

Never place fingers, hands, or any body part near or directly in front of the spray gun fluid tip. The force of the liquid as it exits the spray tip can cause serious injury by shooting liquid through the skin. NEVER LOOK DIRECTLY INTO THE GUN SPRAY TIP OR POINT THE GUN AT OR NEAR ANOTHER PERSON.

(TREAT THE GUN AS IF IT WERE A LOADED PISTOL)

3.1 Emergency Stop Procedures

The following steps should be followed in order to stop the machinery in an emergency situation:

1. The yellow air valve located where the air enters the machine should be pushed to the "OFF" (closed) position. To do this simply push on the lever protruding out the side of the valve. This will also cause all the system air to bleed out of the system in a matter of a few seconds thus making the system incapable of operating.



Step 2 is a precautionary step and should be followed whenever the emergency stop valve is activated to the stop mode. Failure to do so will damage regulators and components when reactivating to the ON position.

2. Turn all system regulators to OFF (counterclockwise) position.



Verify that the Catalyst Pressure Relief Line and the Resin Return Line are secured before relieving catalyst and resin fluid pressure.

3. Catalyst pressure in the Slave Pump can be eliminated by rotating the yellow valve handle on the Slave Pump 90 degrees to the "ON" position.



The "ON" position the valve handle is parallel (in line) with the valve body .

The "OFF" position the valve handle is perpendicular (across) the valve body.

4. Resin pressure can be eliminated by rotating the yellow handled valve on the bottom of the fluid filter 90 degrees. Place a container under the bottom of the valve to catch any resin that is ejected from the valve.

3.2 General Safety Precautions

The following general safety precautions should be followed when servicing or operating this equipment to ensure operator safety:

- When filling catalyst container, protective eye equipment must be worn to protect against injuries.
- Always maintain adequate material levels to prevent loss of prime during system operation.
- At the first sign of a leak, stop operations, activate emergency stop valve, back off air regulators and open all bleed valves to remove all pressure from the gun, hoses, pump, catalyst system and any other liquid containers.
- Solvent Pot Pressure Relief:
- Turn Solvent Pressure Regulator counter clock wise (ccw) until regulator handle stops.
- Open Petcock valve to bleed Solvent Tank pressure completely.
- Catalyst Injector Pressure Relief:
- Refer to Catalyst Injector User Manual for proper pressure relief.
- Never operate a Fiberglass System with fixed Pinch Point guards removed from system.
- Do not operate Fiberglass Chopper Guns without protective covers in place.
- Correct packing or valve seat leaks immediately.
- Never immerse the gun in any liquid.
- Periodically check operation of catalyst alarms to make sure they are operation properly.
- Frequently check condition of hoses. Replace worn hoses and other parts before they fail.
- Catalyst fluid nozzles and seals **MUST** be in good condition at all times to prevent internal and external leaks. Inspect periodically and replace as needed, or at intervals of three to four months. Use catalyst nozzle seal only once to prevent possible leakage of catalyst into air passages of gun.
- Make absolutely certain that all pressure has been relieved from the gun before disassembly from the hoses before loosening any fittings; from the material or catalyst pump before disassembly; from the catalyst injector before disassembly or filling.
- If you have any doubt that fluid pressure is relieved, call your GlasCraft distributor or GlasCraft, Inc. before proceeding with any disassembly.
- Use only genuine GlasCraft replacement parts when repairing your system. Substitutes may not be the proper material or may not fit the system and may cause dangerous operating conditions and the failure of other components.

3.3 Grounding

Grounding an object means providing an adequate path for the flow of an electrical charge from the object to the ground. An adequate path is one that permits charge to flow from the object fast enough that it will not accumulate to the extent that a spark can be formed. It is not possible to define exactly what will be an adequate path under all conditions since it depends on many variables.

In any event, the grounding means should have the lowest possible electrical resistance. Grounding straps should be installed on all loose conductive objects in the spraying area. This includes material containers and equipment. GlasCraft recommends grounding straps be made of AWG No. 18 stranded wire as a minimum, and that larger wire be used where possible. NFPA Bulletin No. 77 states that the electrical resistance of such a leakage path may be as low as 1 meg ohm (106 ohms) but that resistances as high as 10,000 meg ohms will produce an adequate leakage path in some cases.

Whenever flammable or combustible liquids are transferred from one container to another, or from one container to the equipment, both containers or container and equipment shall be effectively bonded and grounded to dissipate static electricity.

For further information, see **National Fire Protection Association (NFPA) 77** titled "Recommended Practice on Static Electrical". Refer especially to Section 7-7 titled "Spray Application of Flammable and Combustible Materials". Check with local codes and authorities for other specific standards that might apply to your application.



GlasCraft provides a grounding wire and clamp assembly p/n 17440-00 with all FRP equipment.

Never use hard materials such as wire, pins, etc., to clear a plugged gun. Hard materials can cause permanent damage. Dab with a bristle brush, blow backwards with air until clear while wearing a protective eye shield. Repeat as many times as necessary.

Do not perform any maintenance or repairs until you have followed the precautions stated above. If you, as an equipment operator or supervisor, do not feel that you have been adequately trained or instructed and that you lack the technical knowledge to operate or perform maintenance on a piece of GlasCraft equipment, please call GlasCraft, Inc. Before operating or performing maintenance on the equipment.

If you have any questions regarding the above precautions or any service or operation procedures, call your GlasCraft distributor or GlasCraft, Inc.

NOTICE

All statements, information and data given herein are believed to be accurate and reliable but are presented without guaranty, warranty or responsibility of any kind expressed or implied. The user should not assume that all safety measures are indicated or that other measures are not required.

GlasCraft
DISPENSING EXCELLENCE

5845 WEST 82nd STREET, SUITE 102
INDIANAPOLIS, INDIANA 46728 U.S.A.
PHONE (317) 875-5592 FAX (317) 875-5456

Section 4 - Safety Information: Notes

Sec4:2

Section 4 - Safety Information: Limited Warranty Policy

GLASCRAFT, INC. (“GlasCraft”) warrants to the original Purchaser of GlasCraft manufactured equipment and parts, that all GlasCraft manufactured equipment and parts will conform to their published written specifications and be free of defects in workmanship and material for a period of one (1) year from the original date of installation. GlasCraft makes no warranty to anyone other than the original Purchaser.

If any GlasCraft manufactured part or equipment is found to be defective in workmanship or material within the one-year period from the date of installation, as determined solely by GlasCraft, GlasCraft, in its sole discretion, will either repair or replace the defective part or equipment at GlasCraft’s cost, including freight charges both ways, or credit or refund the purchase price for the defective equipment or part.

A warranty claim will be honored only when:

1. GlasCraft has been informed, in writing, of any such defect in workmanship or material within ten (10) days after discovery by the original Purchaser;
2. An official of GlasCraft has issued a return authorization number; and
3. The claimed defective equipment or part has been returned to GlasCraft by the original Purchaser, freight prepaid (with proper return authorization number(s) attached), to: GlasCraft, Inc., 5845 West 82nd Street, Suite 102, Indianapolis, IN 46278, U.S.A.

This warranty shall not apply to any equipment or parts that have been altered or repaired by anyone other than GlasCraft or to defects or damage resulting from improper installation, misuse, negligence, accident, or use not specified by GlasCraft. This warranty shall not apply to any equipment where any parts or components were replaced by any parts or components not manufactured or supplied by GlasCraft. The decision by GlasCraft shall be conclusive and binding on Purchaser.

GlasCraft does not warrant that any equipment or parts sold to Purchaser meet or comply with any local, state, federal, or other jurisdiction’s regulations or codes. GlasCraft does not warrant that any equipment or part sold to Purchaser, when used individually or in concert with any other part, equipment, device, component or process, does not infringe on any patent rights of any third party. GlasCraft only warrants that it has no specific knowledge of any such infringement.

GlasCraft makes no warranty as to any parts or equipment manufactured by others. Purchaser shall look solely and only to the manufacturer of such parts or equipment with respect to any warranty claims. GlasCraft hereby assigns to Purchaser the original manufacturer’s warranties to all such equipment and parts, to the full extent permitted.

THE AFORESAID WARRANTY IS IN LIEU OF ALL OTHER WARRANTIES, EXPRESS OR IMPLIED. SPECIFICALLY THERE ARE NO WARRANTIES OF MERCHANTABILITY OR FITNESS FOR A PARTICULAR PURPOSE, WHICH WARRANTIES ARE SPECIFICALLY DISCLAIMED.

GlasCraft shall not be liable for any loss or expense resulting from damage or accidents caused by improper use or application of materials manufactured or sold by GlasCraft or its distributors or agents.

UNDER NO CIRCUMSTANCES SHALL GLASCRAFT’S LIABILITY EXCEED THE AMOUNT PURCHASER PAID FOR THE CLAIMED DEFECTIVE EQUIPMENT OR PART. UNDER NO CIRCUMSTANCES SHALL GLASCRAFT BE LIABLE FOR INCIDENTAL OR CONSEQUENTIAL DAMAGES OR FOR LOST PROFITS.

No action arising from or relating to any goods manufactured by or purchased from GlasCraft may be brought more than one (1) year after the cause of action accrues.

Section 4 - Safety Information: Technical Assistance

Thank You for selecting GlasCraft spray equipment

Should you have any questions or need technical assistance, contact your factory authorized GlasCraft distributor.

Distributor: _____

Phone: _____

Contact: _____

For any issues your distributor cannot address, the GlasCraft technical service department is always available to assist you with the operation of your spray equipment. To help our technical representatives expedite your call and better address your questions, please have the following information ready and available when you phone GlasCraft.

*** If your questions are not urgent, You can e-mail all correspondence to service@glascraft.com**

Model: _____

Spray gun: _____

Serial number: _____

Material pump: _____

Serial number: _____

Catalyst pump: _____

Chopper: _____

Serial number: _____

Type of material: _____

Type of catalyst: _____

Catalyst percentage: _____

Air compressor size: _____

Compressor to system supply line: _____

Pressure at the system: _____

Main air line volume: _____

System gauge pressures

AAC pressure: _____

Atomizing air pressure: _____
(external mix)

Material pump pressure: _____

Solvent flush pressure: _____

For Your Reference



Date Purchased _____
Distributor _____

Contact _____
Phone _____
E-mail _____

GlasCraft manufactures a complete line of FRP spray systems. If your application is in-plant or a field contractor - GlasCraft has a system package to meet your requirements.

***FORMULA - INTERNAL & EXTERNAL MIX POLYESTER EQUIPMENT
CHOPPER & GELCOAT SYSTEMS***

- . NO NEEDLE IN THE SPRAY GUN
- . INFINITELY ADJUSTABLE CATALYST PUMP

INDY - INTERNAL & EXTERNAL MIX EQUIPMENT

- . LOWEST LEVEL OF EMISSIONS
- . AUTOMATIC EQUIPMENT FOR ROBOT APPLICATIONS

SPARTAN - CLOSED MOLD / RTM EQUIPMENT

- . HAND HELD & DELUXE MODELS
- . PROGRAMMABLE CATALYST PERCENTAGES

SPECIALTY DISPENSE EQUIPMENT

- . APD - HIGH VISCOSITY POLYESTER PUTTY DISPENSE
- . RCD - RESIN / CATALYST DISPENSE
- . PFR - PRESSURE FED ROLLERS

For more information concerning any of these GlasCraft products,
contact your local authorized GlasCraft distributor or visit www.glascraft.com



Quality and Performance...
GENUINE GLASCRAFT

Glas **Craft**
DISPENSING EXCELLENCE



www.glascraft.com

GC-1355
REVISION F.2

5845 WEST 82nd STREET
INDIANAPOLIS, INDIANA 46278
U.S.A.

Phone (317) 875-5592
Fax (317) 875-5456
E-Mail sales@glascraft.com