

# USER MANUAL

## SSP *Super Slave Pump*

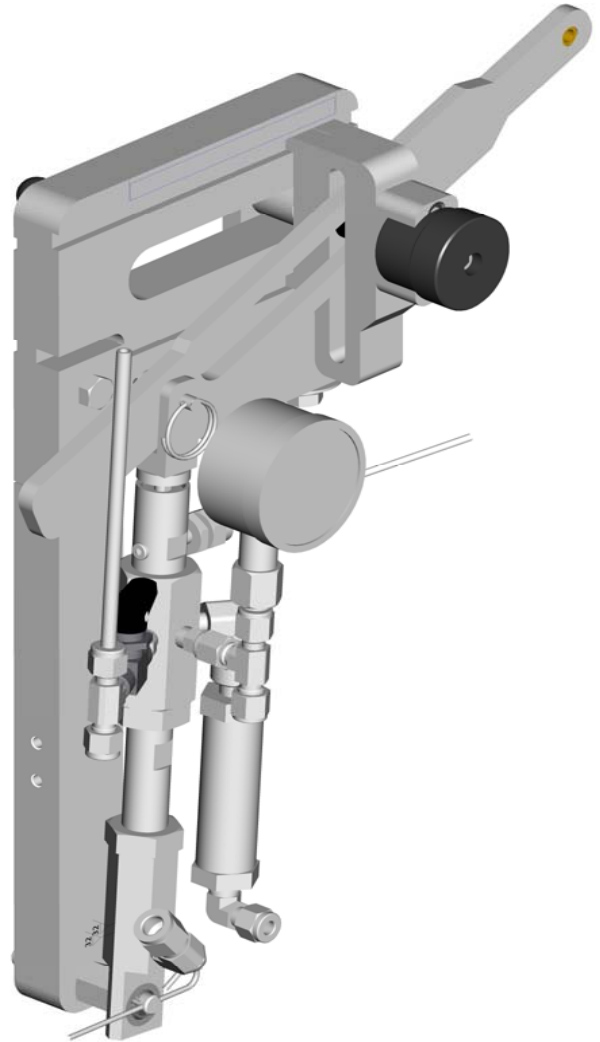

# Table Of Contents

## Section 1 Installation

1:1 Introduction .....	1
1:2 Standard Equipment .....	2
1:3 Specifications .....	N/A
1:4 Equipment Assembly .....	3

## Section 2 Operation

2:1 New System Start-up Instructions .....	N/A
2:2 Shut-down Instructions .....	N/A
2:3 Daily Start-Up Instructions .....	N/A

## Section 3 General Information

3:1 Assembly Drawings .....	4
3:2 Sub Assembly Drawings .....	N/A
3:3 Maintenance .....	9
3:4 Troubleshooting .....	N/A
3:5 Options .....	N/A

## Section 4 Safety Information

4:1 General Safely .....	10
4:2 Notes .....	18
4:3 Limited Warranty Policy .....	19
4:4 Technical Assistance .....	20
For Your Reference .....	<b>INSIDE BACK COVER</b>

N/A = None Applicable

# Section 1 - Installation

## Introduction

Before operating, maintaining or servicing any **GlasCraft** system, read and understand all of the technical and safety literature provided with **GlasCraft** products. If you do not have the proper or related manuals and safety literature for your **GlasCraft** system, contact your **GlasCraft** distributor or **GlasCraft, Inc.**

In this **GlasCraft** technical and safety publication, the following advisories will be provided where appropriate:



Is information about the procedure in progress.



*Is imperative information about equipment protection.*



*Indicates a hazardous situation which, if not avoided, could result in minor or moderate injury.*



*Indicates a hazardous situation which, if not avoided, could result in death or serious injury.*



*Indicates a hazardous situation which, if not avoided, could result in electrical shock or serious injury.*

The information in this document is intended only to indicate the components and their normal working relationship typical use. Each assembly should be directed by a **GlasCraft** distributor or made from the **GlasCraft** Assembly instructions provided.

This manual provides information for the assembly, operation, maintenance and service of this **GlasCraft** product as used in a typical configuration. While it lists standard specifications and procedures, some deviations may be found.

In order to provide our users with the most up-to-date technology possible, we are constantly seeking to improve products. If technological change occurs after a product is on the market, we will implement that technology in future production and, if practical, make it available to current users as a retrofit, up-date or supplement. If you find some discrepancy between your unit and the available documentation, contact your **GlasCraft** distributor to resolve the difference. **GlasCraft, Inc.** reserves the right to change or modify this product as it deems necessary.

Careful study and continued use of this manual will provide a better understanding of the equipment and process, resulting in more efficient operation, longer trouble-free service and faster, easier troubleshooting.

## Section 1 - Installation: Standard Equipment

### Model - Super Slave Pump

<b>Part Number</b>	<b>Description</b>
SSP-160-XX	SUPER SLAVE PUMP
GC-1337	USER MANUAL

## Section 1 - Installation: Equipment Assembly

1. Attach the slave pump assembly to the fluid section plate.

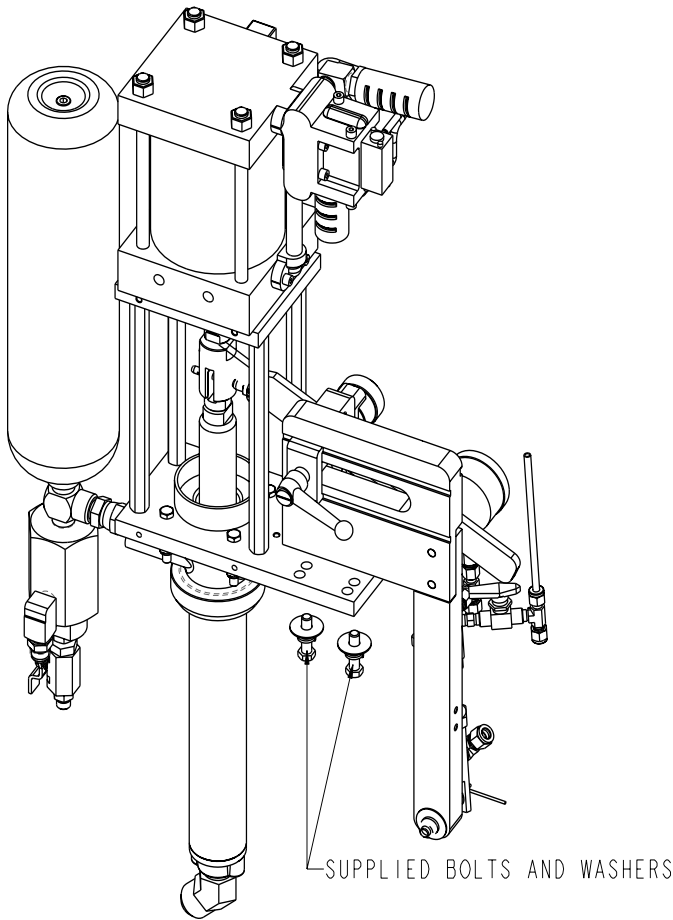

2. Attach the slave pump drive arm to pump shaft.

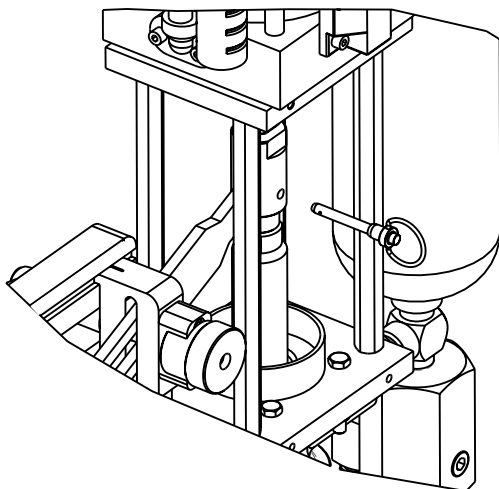

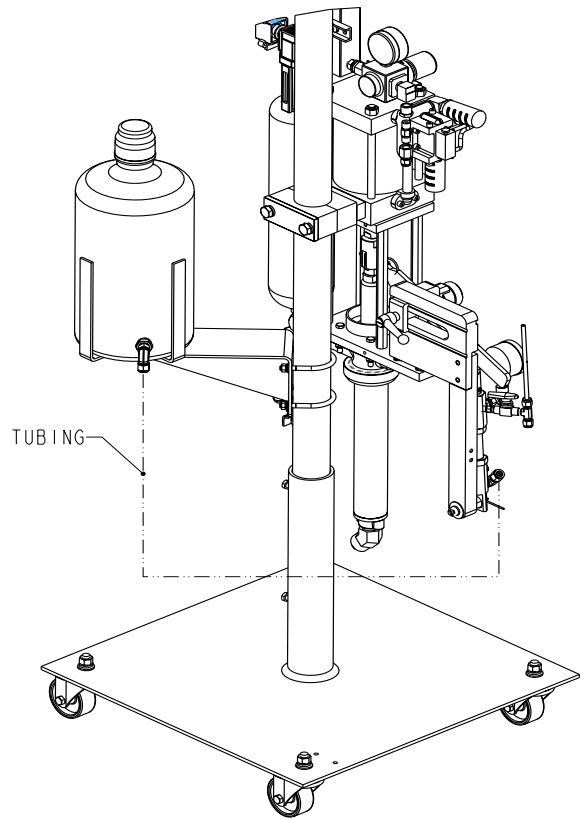

3. Install the tubing from the catalyst pump to the catalyst jug. Use two wrenches to carefully tighten compression nuts to lock the tubing down.

 The tubing must be cut to desired length, giving a natural gravity feed supply to the slave pump.

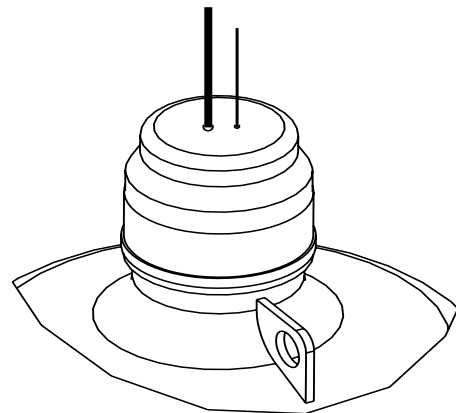

4. Install the catalyst and bypass tubing into the holes in the catalyst jug cap. **Make sure the filter screen is in place under the cap.**



 Refer to system manuals for proper start-up and shut down.

## Section 3 - General Information: Assembly Drawings

### SSP-160-01 Super Slave Pump

Sec. 3:1

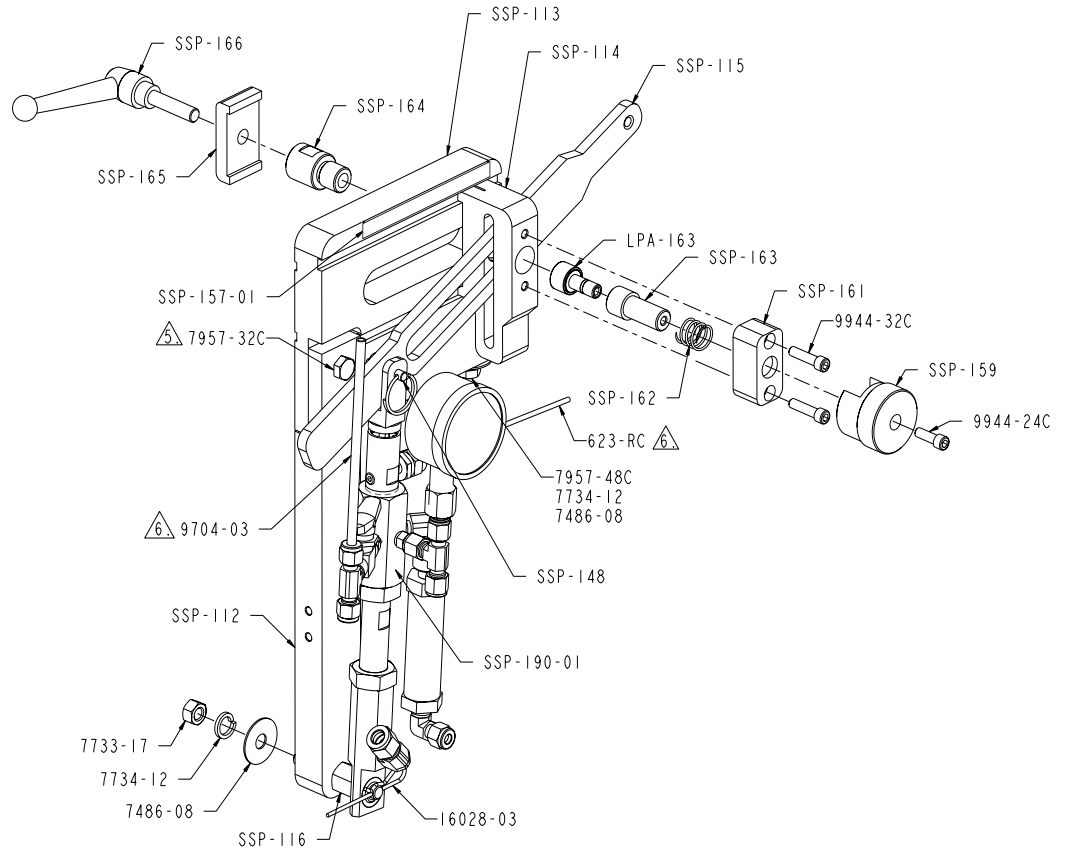

⚠ BOTH RETURN LINES P/N 9704-03 AND 623-RC, RUN FROM THE SLAVE PUMP ASSY. TO THE CATALYST BOTTLE.

⚠ USE BLUE LOCTITE (#24231-242) AS NEEDED, BOTH SCREWS.

Part Number	Description	Qty.
LPA-163	CAM, FOLLOWER	1
SSP-112	PLATE EXTENSION	1
SSP-113	PLATE ADAPTER	1
SSP-114	SLAVE PUMP SLIDER	1
SSP-115	SLAVE PUMP DRIVE ARM	1
SSP-116	HEX ADAPTER	1
SSP-148	RELEASE PIN	1
SSP-157-01	CALIBRATION DECAL	1
SSP-159	PIVOT KNOB	1
SSP-161	SLAVE PUMP LOCK	1
SSP-162	COMPRESSION SPRING	1
SSP-163	PIVOT HANDLE	1

Part Number	Description	Qty.
SSP-164	SLIDER INSERT	1
SSP-165	SLIDER LOCK	1
SSP-166	CLAMPING HANDLE	1
SSP-190-01	SLAVE PUMP	1
16028-03	HITCH PIN	1
623-RC	TUBING	5
7486-08	WASHER	3
7733-17	HEX NUT	1
7734-12	LOCK WASHER	3
7957-32C	SCREW	2
7957-48C	SCREW	2
9704-03	TUBING	5
9944-24C	SCREW	1
9944-32C	SCREW	2

## Section 3 - General Information: Assembly Drawings

### SSP-160-02 Super Slave Pump

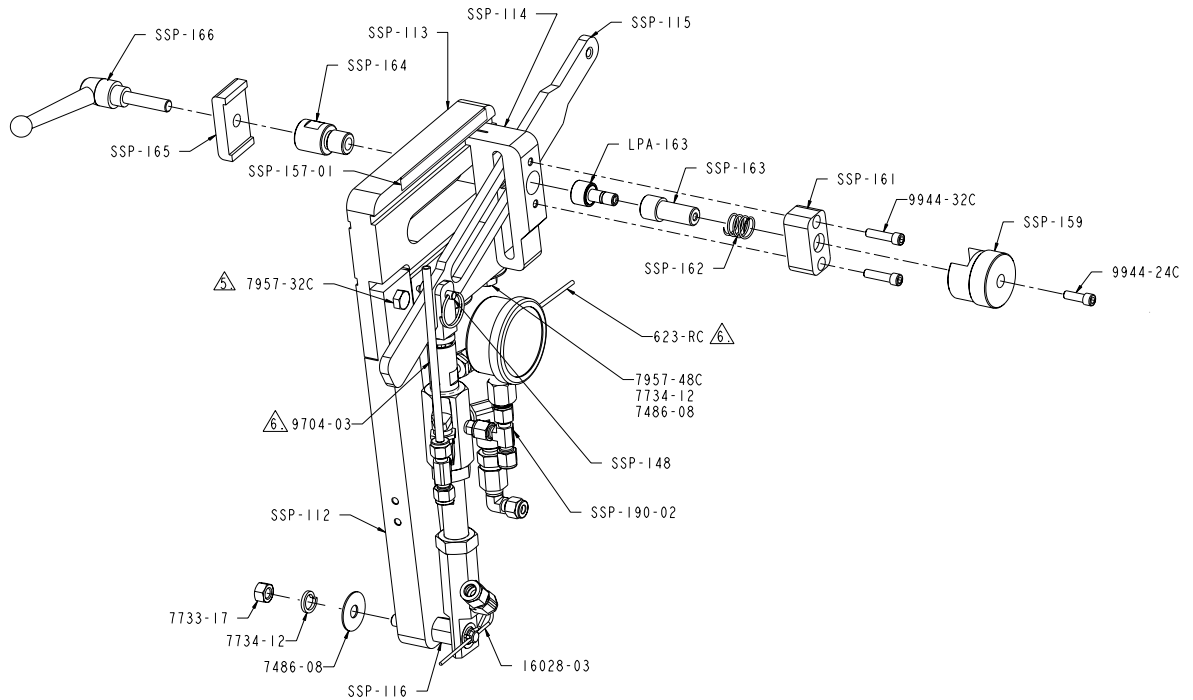

△ BOTH RETURN LINES P/N 9704-03 AND 623-RC, RUN FROM THE SLAVE PUMP ASSY. TO THE CATALYST BOTTLE.

△ USE BLUE LOCTITE (#24231-242) AS NEEDED, BOTH SCREWS.

Part Number	Description	Qty.
LPA-163	CAM, FOLLOWER	1
SSP-112	PLATE EXTENSION	1
SSP-113	PLATE ADAPTER	1
SSP-114	SLAVE PUMP SLIDER	1
SSP-115	SLAVE PUMP DRIVE ARM	1
SSP-116	HEX ADAPTER	1
SSP-148	RELEASE PIN	1
SSP-157-01	CALIBRATION DECAL	1
SSP-159	PIVOT KNOB	1
SSP-161	SLAVE PUMP LOCK	1
SSP-162	COMPRESSION SPRING	1
SSP-163	PIVOT HANDLE	1

Part Number	Description	Qty.
SSP-164	SLIDER INSERT	1
SSP-165	SLIDER LOCK	1
SSP-166	CLAMPING HANDLE	1
SSP-190-02	SLAVE PUMP	1
16028-03	HITCH PIN	1
623-RC	TUBING	5
7486-08	WASHER	3
7733-17	HEX NUT	1
7734-12	LOCK WASHER	3
7957-32C	SCREW	2
7957-48C	SCREW	2
9704-03	TUBING	5
9944-24C	SCREW	1
9944-32C	SCREW	2

Sec. 3:1

## Section 3 - General Information: Assembly Drawings

### SSP-160-04 Super Slave Pump

Sec. 3:1

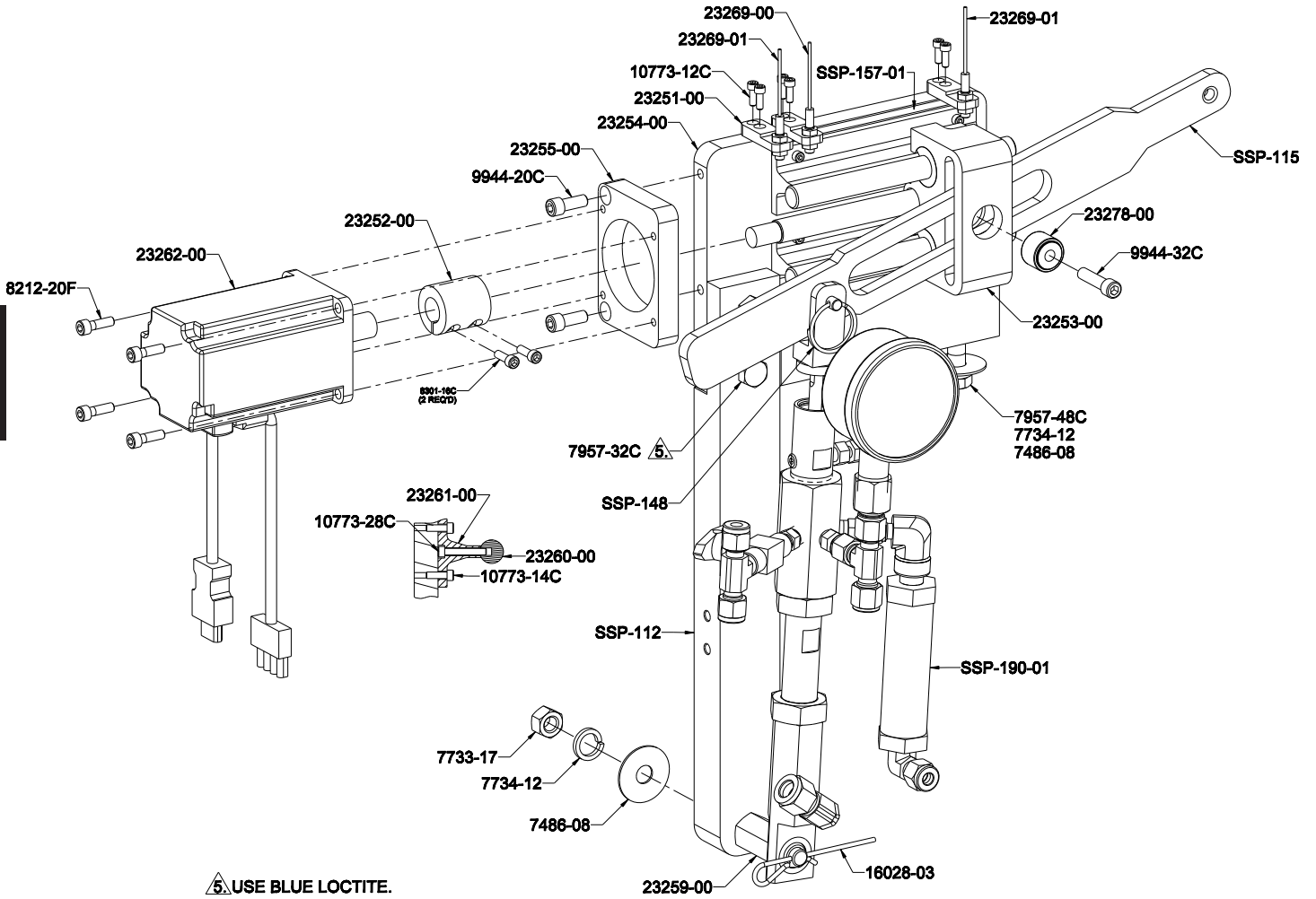

5. USE BLUE LOCTITE.

Part Number	Description	Qty.
10773-12C	SCREW	6
10773-14C	SCREW	8
10773-28C	SCREW	4
16028-03	HITCH PIN	1
23251-00	MOUNTING BRACKET	3
23252-00	MOTOR COUPLER	1
23253-00	SLAVE SLIDER	1
23254-00	ADJUSTABLE MOUNT	1
23255-00	ADAPTER PLATE	1
23256-00	ADJUSTMENT ROD	1
23259-00	HEX ADAPTER	1
23260-00	PRECISION ROD	2
23261-00	SUPPORT RAIL	2
23262-00	SERVO MOTOR	1
23269-00	NORMALLY OPEN SENSOR	1
23269-01	NORMALLY CLOSED SENSOR	2

Part Number	Description	Qty.
23278-00	ROLLER BEARING	1
7486-08	WASHER	3
7733-17	HEX NUT	1
7734-12	LOCK WASHER	3
7957-32C	SCREW	2
7957-48C	SCREW	2
8212-20F	SCREW	4
8301-16C	SCREW	2
9944-20C	SCREW	2
9944-32C	SCREW	1
SSP-112	SLAVE PLATE EXTENSION	1
SSP-115	DRIVE ARM	1
SSP-148	RELEASE PIN	1
SSP-157-01	CALIBRATION DECAL	1
SSP-190-01	SLAVE PUMP	1



## Section 3 - General Information: Assembly Drawings

### SSP-190-01 Fluid Section

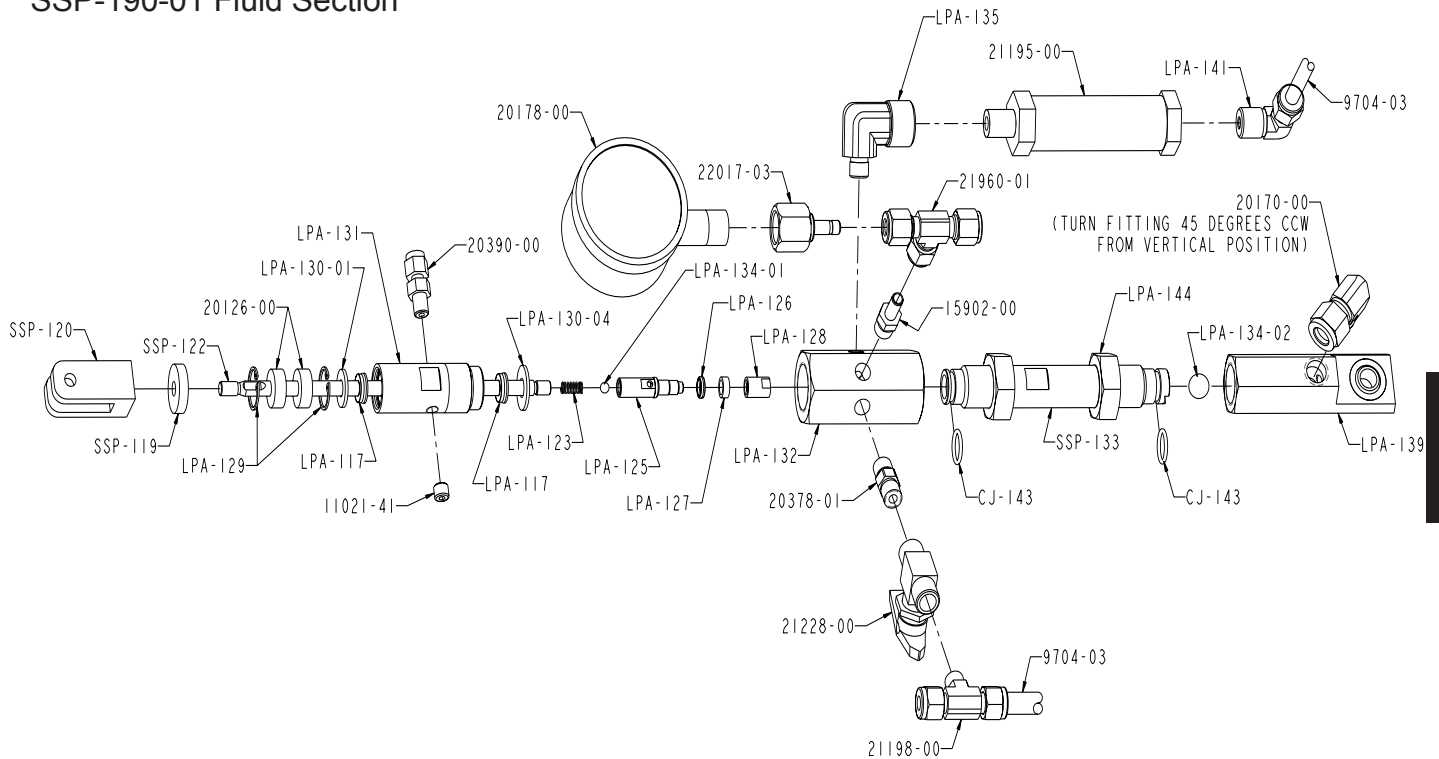

Sec. 3:1

Part Number	Description	Qty.
CJ-143	O-RING	2
LPA-117	SEAL	2
LPA-123	COMPRESSION SPRING	1
LPA-125	TRANSFER HOUSING	1
LPA-126	SEAL	1
LPA-127	PISTON GUIDE	1
LPA-128	GUIDE SUPPORT	1
LPA-129	SNAP RING	2
LPA-130-01	CRUSH WASHER	1
LPA-130-04	CRUSH WASHER	1
LPA-131	SEAL HOUSING	1
LPA-132	PUMP HEAD	1
LPA-134-01	BALL	1
LPA-134-02	BALL	1
LPA-135	ELBOW FITTING	1
LPA-139	PUMP CAP	1
LPA-141	ELBOW FITTING	1

Part Number	Description	Qty.
LPA-144	LOCK NUT	2
SSP-119	SLAVE PUMP BUMPER	1
SSP-120	"Y" BRACKET	1
SSP-122	PUMP SHAFT	1
SSP-133	PUMP CYLINDER	1
11021-41	PIPE PLUG	1
15902-00	TUBE FITTING	1
20126-00	FELT WIPER	2
20170-00	ELBOW FITTING	1
20178-00	PRESSURE GAUGE	1
20378-01	FITTING	1
20390-00	FITTING	1
21195-00	RELIEF VALVE	1
21198-00	TEE FITTING	1
21228-00	2-WAY BALL VALVE	1
21960-01	TEE FITTING	1
22017-03	TUBE ADAPTER	1
9704-03	TUBING	0.583

**NOTE:** Do not attempt to remove the teflon insert inside LPA-131.  
**SEAL KIT:** LPA-190-SK

## Section 3 - General Information: Assembly Drawings

### SSP-190-02 Fluid Section

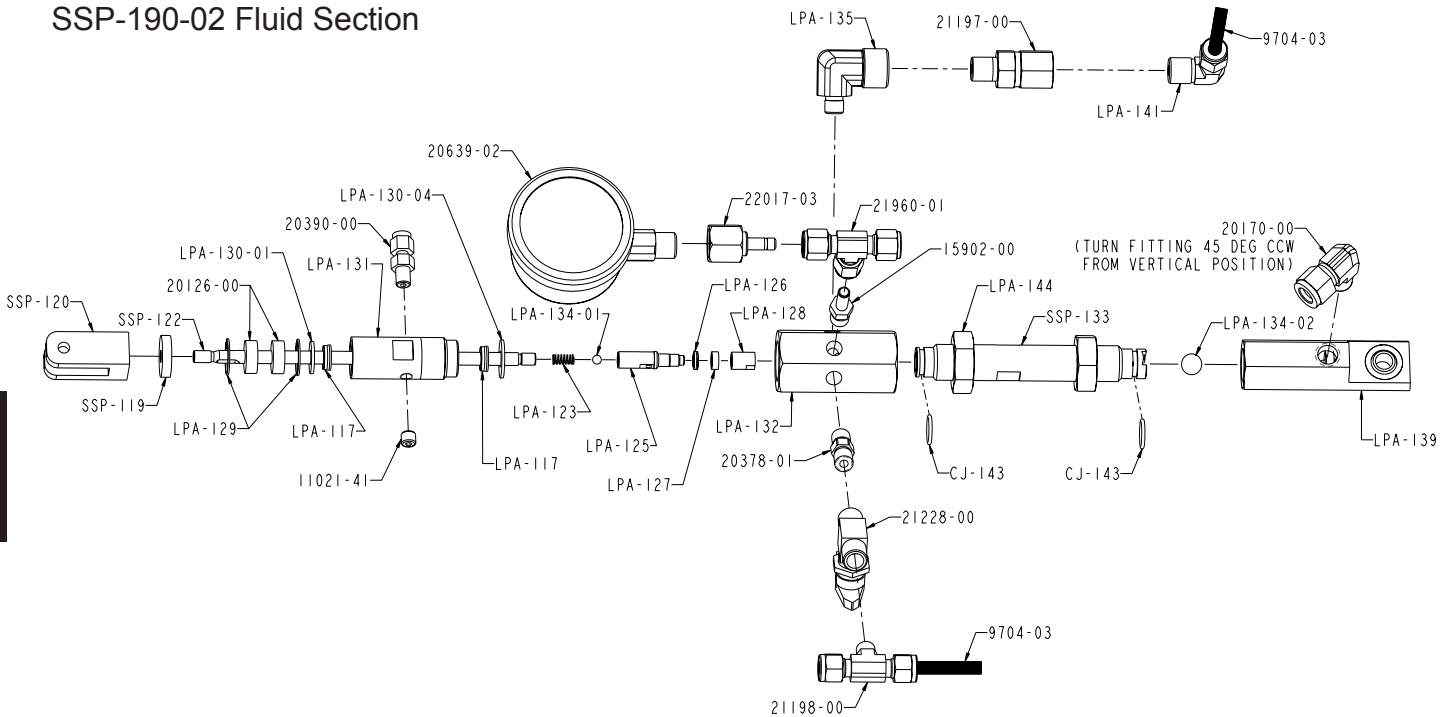

Sec. 3:1

Part Number	Description	Qty.
CJ-143	O-RING	2
LPA-117	SEAL	2
LPA-123	COMPRESSION SPRING	1
LPA-125	TRANSFER HOUSING	1
LPA-126	SEAL	1
LPA-127	PISTON GUIDE	1
LPA-128	GUIDE SUPPORT	1
LPA-129	SNAP RING	2
LPA-130-01	CRUSH WASHER	1
LPA-130-04	CRUSH WASHER	1
LPA-131	SEAL HOUSING	1
LPA-132	PUMP HEAD	1
LPA-134-01	BALL	1
LPA-134-02	BALL	1
LPA-135	ELBOW FITTING	1
LPA-139	PUMP CAP	1
LPA-141	ELBOW FITTING	1

Part Number	Description	Qty.
LPA-144	LOCK NUT	2
SSP-119	SLAVE PUMP BUMPER	1
SSP-120	"Y" BRACKET	1
SSP-122	PUMP SHAFT	1
SSP-133	PUMP CYLINDER	1
11021-41	PIPE PLUG	1
15902-00	TUBE FITTING	1
20126-00	FELT WIPER	2
20170-00	ELBOW FITTING	1
20378-01	FITTING	1
20390-00	FITTING	1
20639-02	GAUGE	1
21197-00	RELIEF VALVE	1
21198-00	TEE FITTING	1
21228-00	2-WAY BALL VALVE	1
21960-01	TEE FITTING	1
22017-03	TUBE ADAPTER	1
9704-03	TUBING	0.583

**NOTE:** Do not attempt to remove the teflon insert inside LPA-131.  
**SEAL KIT:** LPA-190-SK

## Section 3 - General Information: Maintenance

### Weekly Maintenance

1. Remove catalyst check valve. Pull the poppet at the end of the check valve lightly with your hand. Inspect and clean any contamination. Replace into gun.
2. Clean filter at resin pump. When opening pump relief valve, make sure all resin and air is evacuated from surge bottle.
3. Inspect and clean filter on pick-up wand.
4. Clean pump lube cup and add fresh pump lube.

### Repair Kits:

<b>LPA-190-RK</b>		
<b>Part Number</b>	<b>Description</b>	<b>Qty.</b>
CJ-143	O-RING	2
CJ-154	O-RING	1
D-123-10	O-RING	1
LPA-117	SEAL	2
LPA-126	SEAL	1
LPA-127	PISTON GUIDE	1
LPA-118	TUBING	1.75 FT.
LPA-123	SPRING	1
LPA-130-04	CRUSH WASHER	1
LPA-134-01	BALL	1
LPA-134-02	BALL	1
LPA-157	DECAL	1
9704-11	TUBING	5 FT.
9704-03	TUBING	1 FT.
20126-00	FELT WIPER	2
17653-01	FRONT FERRULE	1
17653-26	BACK FERRULE	1

<b>LPA-190-SK</b>		
<b>Part Number</b>	<b>Description</b>	<b>Qty.</b>
CJ-143	O-RING	2
CJ-154	O-RING	1
D-123-10	O-RING	1
LPA-117	SEAL	2
LPA-126	SEAL	1
LPA-127	PISTON GUIDE	1
LPA-130-04	CRUSH WASHER	1
20126-00	FELT WIPER	2

## Section 4 - Safety Information: General Safety

### Operating Your Polyester System Safely

#### 1.0 Introduction

Any tool, if used improperly, can be dangerous. Safety is ultimately the responsibility of those using the tool. In like manner, safe operation of polyester processes is the responsibility of those who use such processes and those who operate the equipment. This manual outlines procedures to be followed in conducting polyester operations safely.

This system has been specifically designed for use of Polyester Resin, Gel-Coat, and Methyl Ethyl Ketone Peroxides (MEKP) applications. Other formulations or blends considered for use in this equipment is strictly prohibited without the expressed consent by GlasCraft Inc.

GlasCraft, Inc. cannot eliminate every danger nor foresee every circumstance that might cause an injury during equipment operation. Some risks, such as the high pressure liquid stream that exits the spray tip, are inherent to the nature of the machine operation and are necessary to the process in order to manufacture the end-product. For this reason, ALL personnel involved in polyester operations should read and understand the Safety Manual. It is very important for the safety of employees involved in the operation that equipment operators, maintenance and supervisory personnel understand the requirements for safe operation.

Each user should examine his own operation, develop his own safety program and be assured that his equipment operators follow correct procedures. GlasCraft hopes that this manual is helpful to the user and recommends that the precautions in this manual be included in any such program. GlasCraft recommends this Safety Manual remain on your equipment at all times for your personnel safety.

In addition to the manual, GlasCraft recommends that the user consult the regulations established under the Occupational Safety & Health Act (OSHA), particularly the following sections:

- 1910.94 Pertaining to ventilation.
- 1910.106 Pertaining to flammable liquids.
- 1910.107 Pertaining to spray finishing operations,

particularly Paragraph (m) Organic Peroxides and Dual Component Coatings.

Other standards and recognized authorities to consult are the National Fire Protection Association (NFPA) bulletins as follows:

- NFPA No. 33 Chapter 14, Organic Peroxides and Dual Component Materials
- NFPA No. 63 Dust Explosion Prevention
- NFPA No. 70 National Electrical Code
- NFPA No. 77 Static Electricity
- NFPA No. 91 Blower and Exhaust System
- NFPA No. 654 Plastics Industry Dust Hazards
- Type of Fire Extinguishing equipment recommended :

Fire Extinguisher -- code ABC, rating number 4a60bc. Extinguishing Media -- Foam, Carbon Dioxide, Dry Chemical, Water Fog.

Copies of the above bulletins are available, at a nominal charge from:

National Fire Protection Association  
470 Atlantic Avenue  
Boston, MA 02210

Research Report No. 11 of the American Insurance Association deals with "Fire, Explosion and Health Hazards of Organic Peroxides". It is published by...

American Insurance Association  
85 John Street  
New York, New York 10038

Local codes and authorities also have standards to be followed in the operation of your spraying equipment. Your insurance carrier will be helpful in answering questions that arise in your development of safe procedures.

#### 1.2 Personnel Safety Equipment

GlasCraft recommends the following Personal Safety Equipment for conducting safe operations of the Polyester Systems:



EYE PROTECTION



HEARING PROTECTION



BREATHING PROTECTION

## Section 4 - Safety Information: General Safety

GlasCraft recommends that the user consult the state and local regulations established for all Safety equipment listed.

### 2.0 Material Safety

#### 2.1 Hazards Associated with Laminating Operations

The major hazards which should be guarded against in polyester laminating operations are those associated with:

1. The flammability and explosion dangers of the catalyst normally used - Methyl Ethyl Ketone Peroxide (MEKP).
2. The flammability dangers of clean-up solvents sometimes used (GlasCraft recommends that clean-up solvents be nonflammable), and of resin diluents used, such as styrene.
3. The flammability dangers of catalyst diluents, if used. (GlasCraft recommends that catalyst not be diluted.)
4. The flammability dangers of the uncured liquid resins used.
5. The combustibility dangers of the cured laminate, accumulations of overspray, and laminate sandings.
6. The toxicity dangers of all the chemicals used in laminating operations with respect to ingestion, inhalation and skin and eye hazards.

#### 2.2 Catalyst

##### (Methyl Ethyl Ketone Peroxide)

MEKP is among the more hazardous materials found in commercial channels. The safe handling of the "unstable (reactive)" chemicals presents a definite challenge to the plastics industry. The highly reactive property which makes MEKP valuable to the plastics industry in producing the curing reaction of polyester resins also produces the hazards which require great care and caution in its storage, transportation, handling, processing and disposal.

MEKP is not a single chemical. Various polymeric forms may exist which are more or less hazardous with respect to each other. These differences may arise not only from different molecular structures (all are, nevertheless, called "MEKP") and from possible trace impurities left from the manufacture of the chemicals, but may also arise by contamination of the MEKP with other materials in its storage or use. Even a small amount of contamination with acetone, for instance, may produce an extremely shock-sensitive and explosive compound.

**Contamination with promoters, or materials containing promoters, such as laminate sandings, or with any readily oxidizable material, such as brass or iron, will cause exothermic "redox" reactions which can become explosive in nature.**

**Heat applied to MEKP, or heat build-up from contamination reactions can cause it to reach what is called its Self-Accelerating Decomposition Temperature (SADT).**

Researchers have reported measuring pressure rates-of-rise well in excess of 100,000 psi per second when certain MEKP's reach their SADT. (For comparison, the highest pressure rate-of-rise listed in NFPA Bulletin No. 68, "Explosion Venting", is 12,000 psi per second for an explosion of 12% acetylene and air. The maximum value listed for a hydrogen explosion is 10,000 psi per second.)

Some forms of MEKP, if allowed to reach their SADT, will burst even an open topped container. This suggests that it is not possible to design a relief valve to vent this order of magnitude of pressure rate-of-rise. The user should be aware that any closed container, be it a pressure vessel, surge chamber, or pressure accumulator, could explode under certain conditions. There is no engineering substitute for care by the user in handling organic peroxide catalysts. If, at any time, the pressure relieve valve on top of the catalyst tank should vent, the area should be evacuated at once and the fire department called. The venting could be the first indication of a heat, and therefore, pressure build-up that could eventually lead to an explosion. Moreover, if a catalyst tank is sufficiently full when the pressure relief valve vents, some catalyst may spray out, which could cause eye injury. For this reason, and many others, anyone whose job puts them in an area where this vented spray might go, should always wear full eye protection even when laminating operations are not taking place.

## Section 4 - Safety Information: General Safety

Safety in handling MEKP depends to a great extent on employee education, proper safety instructions and safe use of the chemicals and equipment. Workers should be thoroughly informed of the hazards that may result from improper handling of MEKP, especially in regards to contamination, heat, friction and impact. They should be thoroughly instructed regarding the proper action to be taken in the storage, use and disposal of MEKP and other hazardous materials used in the laminating operation.

In addition, users should make every effort to:

1. Store MEKP in a cool, dry place in original containers away from direct sunlight and away from other chemicals.
2. Keep MEKP away from heat, sparks and open flames.
3. Prevent contamination of MEKP with other materials, including polyester overspray and sandings, polymerization accelerators and promoters, brass, aluminum and non-stainless steels.
4. Never add MEKP to anything that is hot, since explosive decomposition may result.
5. Avoid contact with skin, eyes and clothing. Protective equipment should be worn at all times. During clean-up of spilled MEKP, personal safety equipment, gloves and eye protection must be worn. Fire fighting equipment should be at hand and ready.
6. Avoid spillage, which can heat up to the point of self-ignition.
7. Repair any leaks discovered in the catalyst system immediately, and clean up the leaked catalyst at once in accordance with the catalyst manufacturer's instructions.
8. Use only original equipment or equivalent parts from GlasCraft in the catalyst system (i.e.: hoses, fittings, etc.) because a dangerous chemical reaction may result between substituted parts and MEKP.
9. Catalyst accumulated from the purging of hoses or the measurement of fluid output deliveries should never be returned to the supply tank. such catalyst should be diluted

with copious quantities of clean water and disposed of in accordance with the catalyst manufacturer's instructions.

The extent to which the user is successful in accomplishing these ends and any additional recommendations by the catalyst manufacturer determines largely the safety that will be present in his operation.

### 2.3 Clean-Up Solvents and Resin Diluents

#### **WARNING**

*A hazardous situation may be present in your pressurized fluid system!*

*Hydrocarbon Solvents can cause an explosion when used with aluminum or galvanized components in a closed (pressurized) fluid system (pumps, heaters, filters, valves, spray guns, tanks, etc.)*

*The explosion could cause serious injury, death and/or substantial property damage.*

*Cleaning agents, coatings, paints, etc. may contain Halogenated Hydrocarbon Solvents.*

*Some GlasCraft spray equipment includes aluminum or galvanized components and will be affected by Halogenated Hydrocarbon Solvents.*

There are three key elements to the Halogenated Hydrocarbon (HHC) solvent hazard.

1. **The presence of HHC solvents.** 1,1,1-Trichloroethane and Methylene Chloride are the most common of these solvents. However, other HHC solvents are suspect if used; either as part of paint or adhesives formulation, or for clean-up flushing.
2. **Aluminum or Galvanized Parts.** Most handling equipment contains these elements. In contact with these metals, HHC solvents could generate a corrosive reaction of a catalytic nature.
3. **Equipment capable of withstanding pressure.** When HHC solvents contact aluminum or galvanized parts inside a closed container such as a pump, spray gun, or fluid handling system, the chemical reaction can, over time, result in a build-up of heat and pressure, which can reach explosive proportions. When all three elements are present, the result can be an extremely violent explosion. the reaction can be sustained with very little aluminum or galvanized metal; **any amount of aluminum is too much.**



## Section 4 - Safety Information: General Safety

The reaction is unpredictable. Prior use of an HHC solvent without incident (corrosion or explosion) does NOT mean that such use is safe. These solvents can be dangerous alone (as a clean-up or flushing agent) or when used as a component or a coating material. There is no known inhibitor that is effective under all circumstances. Furthermore, the mixing of HHC solvents with other

materials or solvents, such as MEK, alcohol, and toluene, may render the inhibitors ineffective.

The use of reclaimed solvents is particularly hazardous. Reclaimers may not add any inhibitors. Also, the possible presence of water in reclaimed solvents could feed the reaction.

Anodized or other oxide coatings cannot be relied upon to prevent the explosive reaction. Such coatings can be worn, cracked, scratched, or too thin to prevent contact. There is no known way to make oxide coatings or to employ aluminum alloys which will safely prevent the chemical reaction under all circumstances.

Several solvent suppliers have recently begun promoting HHC solvents for use in coating systems. The increasing use of HHC solvents is increasing the risk. Because of their exemption from many State Implementation Plans as Volatile Organic Compounds (VOC's), their low flammability hazard, and their not being classified as toxic or carcinogenic substances, HHC solvents are very desirable in many respects.

### **WARNING**

*Do not use Halogenated Hydrocarbon solvents in pressurized fluid systems having aluminum or galvanized wetted parts.*

 *GlasCraft is aware of NO stabilizers available to prevent Halogenated Hydrocarbon solvents from reaction under all conditions with aluminum components in a closed fluid system.*

**TAKE IMMEDIATE ACTION...**

*Halogenated Hydrocarbon solvents are dangerous when used with aluminum components in a closed fluid system.*

Consult your material supplier to determine whether your solvent or coating contains Halogenated Hydrocarbon Solvents.

GlasCraft recommends that you contact your solvent supplier regarding the best non-flammable clean-up solvent with the heat toxicity for your application.

If, however, you find it necessary to use flammable solvents, they must be kept in approved, electrically grounded containers.

Bulk solvent should be stored in a well-ventilated, separate building, 50 feet away from your main plant.

You should allow only enough solvent for one day's use in your laminating area.

"NO SMOKING" signs must be posted and observed in all areas of storage or where solvents and other flammable materials are used.

Adequate ventilation (as covered in OSHA Section 1910.94 and NFPA No. 91) is important wherever solvents are stored or used, to minimize, confine and exhaust the solvent vapors. Solvents should be handled in accordance with OSHA Section 1910.106 and 1910.107.

## 2.4 Catalyst Diluents

GlasCraft spray-up and gel-coat systems currently produced are designed so that catalyst diluents are not required. GlasCraft, therefore, recommends that diluents not be used. This avoids the possible contamination which could lead to an explosion due to the handling and mixing of MEKP and diluent. In addition, it eliminates any problems from the diluent being contaminated through rust particles in drums, poor quality control on the part of the diluent supplier, or any other reason. If, however, diluents are absolutely required, contact your catalyst supplier and follow his instructions explicitly. Preferably, the supplier should premix the catalyst to prevent possible "on the job" contamination while mixing.

### **WARNING**

*If diluents are not used, it should be remembered that catalyst spillage, gun, hose and packing leaks are potentially more hazardous, since each drop contains a higher concentration of catalyst, and therefore will react quicker with overspray and the like.*

## 2.5 Uncured Liquid Resin

Resin should be stored in a well ventilated building at least 50 feet from your main plant. In addition, the storage temperature should not exceed 75 degrees F.

## Section 4 - Safety Information: General Safety

In your main plant, store only enough resin for one day's production.

"NO SMOKING" signs must be posted and observed in all areas where resin is stored and/or used.

Refer to OSHA Section 1910.94, 1910.106, 1910.107 and consult resin suppliers for more detailed information.

Adequate ventilation (as covered in OSHA Section 1910.94 and NFPA No. 91) is important wherever solvents are stored or used, to minimize, confine and exhaust the solvent vapors.

Resin must never be stored in an area where MEKP is stored or used.

Open-top drums should not be used, due to possible contamination and possible catalyzation from overspray or spillage of MEKP into drum, which could not only severely damage the polyester spray system, but might also cause the drum of resin to ignite.

When spraying test patterns or purging the gun, always remove the test samples and waste from the building immediately and dispose of them in accordance with your material supplier's recommendations.

### 2.6 Cured Laminate, Overspray and Laminate Sandings Accumulation

Remove all accumulations of overspray, FRP sandings, etc. from the building as they occur. If this waste is allowed to build up, spillage of catalyst is more likely to start a fire. In addition, the fire would burn hotter and longer.

Floor coverings, if used, should be non-combustible.

Spilled or leaked catalyst may cause a fire if it comes in contact with an FRP product, oversprayed chop or resin, FRP sandings or any other material with MEKP.

To prevent this spillage and leakage, you should:

1. Maintain your GlasCraft System. Check the gun several times daily for catalyst and resin packing or valve leaks. REPAIR ALL LEAKS IMMEDIATELY.
2. Never leave the gun hanging over, or lying inside the mold. A catalyst leak in this situation would certainly damage the part, possible the mold, and may cause a fire.

3. Inspect resin and catalyst hoses daily for wear or stress at the entry and exits of the boom sections and at the gun and fittings. Replace if wear or weakness is evident or suspected.

4. Arrange the hoses and fiberglass roving guides so that the fiberglass strands DO NOT rub against any of the hoses at any point. If allowed to rub, the hoses may be cut through, causing a hazardous leakage of material which could increase the danger of fire. Also the material may spew onto personnel in the area.

### 2.7 Toxicity of Chemicals

GlasCraft recommends that you consult OSHA Sections 1910.94, 1910.106, 1910.107 and NFPA No. 33, Chapter 14, and NFPA No. 91.

Contact your chemical supplier(s) and determine the toxicity of the various chemicals used, as well as the best methods to prevent injury, irritation and danger to personnel. Also determine the best methods of first aid treatment for each chemical used in your plant.

### 2.8 Treatment of Chemical Injuries

Great care should be used in handling the chemicals (resins, catalyst and solvents) used in polyester systems. Such chemicals should be treated as if they hurt your skin and eyes and as if they are poison to your body. For this reason, GlasCraft recommends the use of protective clothing and eye wear in using polyester systems.

However, users should be prepared in the event of such an injury. Precautions include:

1. Know precisely what chemicals you are using and obtain information from your chemical supplier on what to do in the event the chemical gets onto your skin or into the eyes, or is swallowed.
2. Keep this information together and easily available so that it may be used by those administering first aid or treating the injured person.
3. Be sure the information from your chemical supplier includes instructions on how to treat any toxic effects the chemicals may have.



## Section 4 - Safety Information: General Safety

### **WARNING**

Contact a doctor immediately in the event of any injury and give him the information you have collected. If your information includes first aid instructions, administer first aid immediately while you are contacting the doctor.

Fast treatment of the outer skin and eyes that contact such chemicals generally includes immediate and thorough washing of the exposed skin and immediate and continuous flushing of the eyes with lots of clean water for at least 15 minutes or more. These general instructions of first aid treatment, however, may be incorrect for some chemicals; that is why you must know the chemicals and treatment before an accident occurs. Treatment for swallowing a chemical frequently depends upon the nature of the chemical.

 Refer to your System User Manual for complete and detailed operating instructions and service information.

### 3.0 Equipment Safety

#### **WARNING**

GlasCraft suggest that personnel safety equipment such as **EYE GOGGLES, GLOVES, EAR PROTECTION, and RESPIRATORS** be worn when servicing or operating this equipment. Ear protection should be worn when operating a fiberglass chopper to protect against hearing loss since noise levels can be as high as 116 dB (decibels). This equipment should only be operated or serviced by technically trained personnel!!!

#### **WARNING**

Never place fingers, hands, or any body part near or directly in front of the spray gun fluid tip. The force of the liquid as it exits the spray tip can cause serious injury by shooting liquid through the skin. **NEVER LOOK DIRECTLY INTO THE GUN SPRAY TIP OR POINT THE GUN AT OR NEAR ANOTHER PERSON. (TREAT THE GUN AS IF IT WERE A LOADED PISTOL)**

### 3.1 Emergency Stop Procedures

The following steps should be followed in order to stop the machinery in an emergency situation:

1. The yellow air valve located where the air enters the machine should be pushed to the "OFF" (closed) position. To do this simply push on the lever protruding out the side of the valve. This will also cause all the system air to bleed out of the system in a matter of a few seconds thus making the system incapable of operating.

 Step 2 is a precautionary step and should be followed whenever the emergency stop valve is activated to the stop mode. Failure to do so will damage regulators and components when reactivating to the ON position.

2. Turn all system regulators to OFF (counter-clockwise) position.

 Verify that the Catalyst Pressure Relief Line and the Resin Return Line are secured before relieving catalyst and resin fluid pressure.

3. Catalyst pressure in the Slave Pump can be eliminated by rotating the yellow valve handle on the Slave Pump 90 degrees to the "ON" position.

 The "ON" position the valve handle is parallel (in line) with the valve body .  
The "OFF" position the valve handle is perpendicular (across) the valve body.

4. Resin pressure can be eliminated by rotating the yellow handled valve on the bottom of the fluid filter 90 degrees. Place a container under the bottom of the valve to catch any resin that is ejected from the valve.

### 3.2 General Safety Precautions

The following general safety precautions should be followed when servicing or operating this equipment to ensure operator safety:

- When filling catalyst container, protective eye equipment must be worn to protect against injuries.
- Always maintain adequate material levels to prevent loss of prime during system operation.
- At the first sign of a leak, stop operations, activate emergency stop valve, back off air regulators and open all bleed valves to remove all pressure from the gun, hoses, pump, catalyst system and any other liquid containers.
- Solvent Pot Pressure Relief:
- Turn Solvent Pressure Regulator counter clock wise (ccw) until regulator handle stops.
- Open Petcock valve to bleed Solvent Tank pressure completely.
- Catalyst Injector Pressure Relief:
- Refer to Catalyst Injector User Manual for proper pressure relief.
- Never operate a Fiberglass System with fixed Pinch Point guards removed from system.
- Do not operate Fiberglass Chopper Guns without protective covers in place.
- Correct packing or valve seat leaks immediately.
- Never immerse the gun in any liquid.
- Periodically check operation of catalyst alarms to make sure they are operation properly.
- Frequently check condition of hoses. Replace worn hoses and other parts before they fail.
- Catalyst fluid nozzles and seals **MUST** be in good condition at all times to prevent internal and external leaks. Inspect periodically and replace as needed, or at intervals of three to four months. Use catalyst nozzle seal only once to prevent possible leakage of catalyst into air passages of gun.
- Make absolutely certain that all pressure has been relieved from the gun before disassembly from the hoses before loosening any fittings; from the material or catalyst pump before disassembly; from the catalyst injector before disassembly or filling.
- If you have any doubt that fluid pressure is relieved, call your GlasCraft distributor or GlasCraft, Inc. before proceeding with any disassembly.
- Use only genuine GlasCraft replacement parts when repairing your system. Substitutes may not be the proper material or may not fit the system and may cause dangerous operating conditions and the failure of other components.

## Section 4 - Safety Information: General Safety

### 3.3 Grounding

Grounding an object means providing an adequate path for the flow of an electrical charge from the object to the ground. An adequate path is one that permits charge to flow from the object fast enough that it will not accumulate to the extent that a spark can be formed. It is not possible to define exactly what will be an adequate path under all conditions since it depends on many variables.

In any event, the grounding means should have the lowest possible electrical resistance. Grounding straps should be installed on all loose conductive objects in the spraying area. This includes material containers and equipment. GlasCraft recommends grounding straps be made of AWG No. 18 stranded wire as a minimum, and that larger wire be used where possible. NFPA Bulletin No. 77 states that the electrical resistance of such a leakage path may be as low as 1 meg ohm (106 ohms) but that resistances as high as 10,000 meg ohms will produce an adequate leakage path in some cases.

Whenever flammable or combustible liquids are transferred from one container to another, or from one container to the equipment, both containers or container and equipment shall be effectively bonded and grounded to dissipate static electricity.

For further information, see **National Fire Protection Association (NFPA) 77** titled "Recommended Practice on Static Electrical". Refer especially to Section 7-7 titled "Spray Application of Flammable and Combustible Materials". Check with local codes and authorities for other specific standards that might apply to your application.

*GlasCraft provides a grounding wire and clamp assembly p/n 17440-00 with all FRP equipment.*

Never use hard materials such as wire, pins, etc., to clear a plugged gun. Hard materials can cause permanent damage. Dab with a bristle brush, blow backwards with air until clear while wearing a protective eye shield. Repeat as many times as necessary.

Do not perform any maintenance or repairs until you have followed the precautions stated above. If you, as an equipment operator or supervisor, do not feel that you have been adequately trained or instructed and that you lack the technical knowledge to operate or perform maintenance on a piece of GlasCraft equipment, please call GlasCraft, Inc. Before operating or performing maintenance on the equipment.

If you have any questions regarding the above precautions or any service or operation procedures, call your GlasCraft distributor or GlasCraft, Inc.

 *All statements, information and data given herein are believed to be accurate and reliable but are presented without guaranty, warranty or responsibility of any kind expressed or implied. The user should not assume that all safety measures are indicated or that other measures are not required.*

**GlasCraft**  
DISPENSING EXCELLENCE

5845 WEST 82nd STREET, SUITE 102  
INDIANAPOLIS, INDIANA 46728 U.S.A.  
PHONE (317) 875-5592 FAX (317) 875-5456



## Section 4 - Safety Information: Limited Warranty Policy

GLASCRAFT, INC. (“GlasCraft”) warrants to the original Purchaser of GlasCraft manufactured equipment and parts, that all GlasCraft manufactured equipment and parts will conform to their published written specifications and be free of defects in workmanship and material for a period of one (1) year from the original date of installation. GlasCraft makes no warranty to anyone other than the original Purchaser.

If any GlasCraft manufactured part or equipment is found to be defective in workmanship or material within the one-year period from the date of installation, as determined solely by GlasCraft, GlasCraft, in its sole discretion, will either repair or replace the defective part or equipment at GlasCraft’s cost, including freight charges both ways, or credit or refund the purchase price for the defective equipment or part.

A warranty claim will be honored only when:

1. GlasCraft has been informed, in writing, of any such defect in workmanship or material within ten (10) days after discovery by the original Purchaser;
2. An official of GlasCraft has issued a return authorization number; and
3. The claimed defective equipment or part has been returned to GlasCraft by the original Purchaser, freight prepaid (with proper return authorization number(s) attached), to: GlasCraft, Inc., 5845 West 82nd Street, Suite 102, Indianapolis, IN 46278, U.S.A.

This warranty shall not apply to any equipment or parts that have been altered or repaired by anyone other than GlasCraft or to defects or damage resulting from improper installation, misuse, negligence, accident, or use not specified by GlasCraft. This warranty shall not apply to any equipment where any parts or components were replaced by any parts or components not manufactured or supplied by GlasCraft. The decision by GlasCraft shall be conclusive and binding on Purchaser.

GlasCraft does not warrant that any equipment or parts sold to Purchaser meet or comply with any local, state, federal, or other jurisdiction’s regulations or codes. GlasCraft does not warrant that any equipment or part sold to Purchaser, when used individually or in concert with any other part, equipment, device, component or process, does not infringe on any patent rights of any third party. GlasCraft only warrants that it has no specific knowledge of any such infringement.

GlasCraft makes no warranty as to any parts or equipment manufactured by others. Purchaser shall look solely and only to the manufacturer of such parts or equipment with respect to any warranty claims. GlasCraft hereby assigns to Purchaser the original manufacturer’s warranties to all such equipment and parts, to the full extent permitted.

**THE AFORESAID WARRANTY IS IN LIEU OF ALL OTHER WARRANTIES, EXPRESS OR IMPLIED. SPECIFICALLY THERE ARE NO WARRANTIES OF MERCHANTABILITY OR FITNESS FOR A PARTICULAR PURPOSE, WHICH WARRANTIES ARE SPECIFICALLY DISCLAIMED.**

GlasCraft shall not be liable for any loss or expense resulting from damage or accidents caused by improper use or application of materials manufactured or sold by GlasCraft or its distributors or agents.

**UNDER NO CIRCUMSTANCES SHALL GLASCRAFT’S LIABILITY EXCEED THE AMOUNT PURCHASER PAID FOR THE CLAIMED DEFECTIVE EQUIPMENT OR PART. UNDER NO CIRCUMSTANCES SHALL GLASCRAFT BE LIABLE FOR INCIDENTAL OR CONSEQUENTIAL DAMAGES OR FOR LOST PROFITS.**

No action arising from or relating to any goods manufactured by or purchased from GlasCraft may be brought more than one (1) year after the cause of action accrues.

## Section 4 - Safety Information: Technical Assistance.....

### **Thank You for selecting GlasCraft spray equipment**

Should you have any questions or need technical assistance, contact your factory authorized GlasCraft distributor.

Distributor: \_\_\_\_\_

Phone: \_\_\_\_\_

Contact: \_\_\_\_\_



For any issues your distributor cannot address, the GlasCraft technical service department is always available to assist you with the operation of your spray equipment. To help our technical representatives expedite your call and better address your questions, please have the following information ready and available when you phone GlasCraft.

**\* If your questions are not urgent, You can e-mail all correspondence to [service@glascraft.com](mailto:service@glascraft.com)**

Model: \_\_\_\_\_

Spray gun: \_\_\_\_\_

Serial number: \_\_\_\_\_

Material pump: \_\_\_\_\_

Serial number: \_\_\_\_\_

Catalyst pump: \_\_\_\_\_

Chopper: \_\_\_\_\_

Serial number: \_\_\_\_\_

Type of material: \_\_\_\_\_

Type of catalyst: \_\_\_\_\_

Catalyst percentage: \_\_\_\_\_

Air compressor size: \_\_\_\_\_

Compressor to system supply line: \_\_\_\_\_

Pressure at the system: \_\_\_\_\_

Main air line volume: \_\_\_\_\_

#### *System gauge pressures*

AAC pressure: \_\_\_\_\_

Atomizing air pressure: \_\_\_\_\_  
(external mix)

Material pump pressure: \_\_\_\_\_

Solvent flush pressure: \_\_\_\_\_

For Your Reference



Date Purchased \_\_\_\_\_  
Distributor \_\_\_\_\_  
\_\_\_\_\_

Contact \_\_\_\_\_  
Phone \_\_\_\_\_  
E-mail \_\_\_\_\_

GlasCraft manufactures a complete line of FRP spray systems. If your application is in-plant or a field contractor - GlasCraft has a system package to meet your requirements.

***FORMULA - INTERNAL & EXTERNAL MIX POLYESTER EQUIPMENT  
CHOPPER & GELCOAT SYSTEMS***

- . NO NEEDLE IN THE SPRAY GUN
- . INFINITELY ADJUSTABLE CATALYST PUMP

***INDY - INTERNAL & EXTERNAL MIX EQUIPMENT***

- . LOWEST LEVEL OF EMISSIONS
- . AUTOMATIC EQUIPMENT FOR ROBOT APPLICATIONS

***SPARTAN - CLOSED MOLD / RTM EQUIPMENT***

- . HAND HELD & DELUXE MODELS
- . PROGRAMMABLE CATALYST PERCENTAGES

***SPECIALTY DISPENSE EQUIPMENT***

- . APD - HIGH VISCOSITY POLYESTER PUTTY DISPENSE
- . RCD - RESIN / CATALYST DISPENSE
- . PFR - PRESSURE FED ROLLERS

For more information concerning any of these GlasCraft products,  
contact your local authorized GlasCraft distributor or visit [www.glascraft.com](http://www.glascraft.com)

Quality and Performance...

GENUINE GLASCRAFT

**Glas**.....**Craft**

DISPENSING EXCELLENCE



[www.glascraft.com](http://www.glascraft.com)

GC-1337  
REVISION Oct. 2007

5845 WEST 82nd STREET  
INDIANAPOLIS, INDIANA 46278  
U.S.A.

Phone (317) 875-5592  
Fax (317) 875-5456  
E-Mail [sales@glascraft.com](mailto:sales@glascraft.com)