

USER MANUAL

MH VR

Dispensing System

**For use with non-flammable foam and polyurea.
Not for use in explosive atmospheres.**

**Maximum working fluid pressure:
3200 psi. (22.06 MPa, 217.73 bar)**



Important Safety Instructions

Read all warnings and instructions in this manual. Save these instructions.

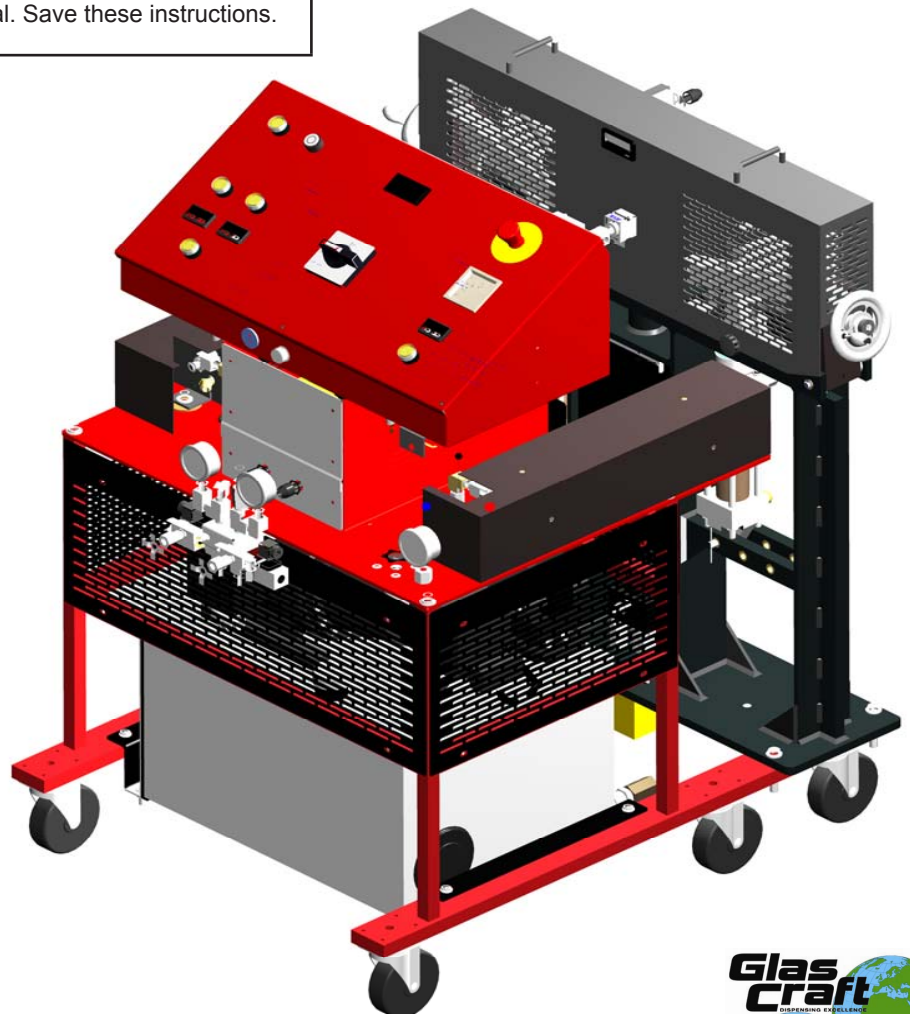

Table Of Contents

Section 1 Installation

Warnings	1
Introduction	5
Standard Equipment	6
Equipment Assembly	7

Section 2 Operation

Start-up Instructions	13
Shut-down Instructions	19
Daily Start-Up Instructions	20

Section 3 General Information

Assembly Drawings	21
Sub Assembly Drawings	34





Section 4 Warranty and Reference Information

Notes	52
Technical Data	53
Limited Warranty Policy	54
Technical Assistance	55
For Your Reference	INSIDE BACK COVER

N/A = Non Applicable





Warnings

The following warnings are for the setup, use, grounding, maintenance, and repair of this equipment. The exclamation point symbol alerts you to a general warning and the hazard symbol refers to procedure-specific risk. Refer back to these warnings. Additional, product-specific warnings may be found throughout the body of this manual where applicable.

 WARNING	
	<p>ELECTRIC SHOCK HAZARD Improper grounding, setup, or usage of the system can cause electric shock.</p> <ul style="list-style-type: none"> • Turn off and disconnect power cord before servicing equipment. • Use only grounded electrical outlets. • Use only 3-wire extension cords. • Ensure ground prongs are intact on sprayer and extension cords. • Do not expose to rain. Store indoors.
	<p>TOXIC FLUID OR FUMES HAZARD Toxic fluids or fumes can cause serious injury or death if splashed in the eyes or on skin, inhaled, or swallowed.</p> <ul style="list-style-type: none"> • Read MSDS's to know the specific hazards of the fluids you are using. • Store hazardous fluid in approved containers, and dispose of it according to applicable guidelines. • Always wear impervious gloves when spraying or cleaning equipment.
	<p>PERSONAL PROTECTIVE EQUIPMENT You must wear appropriate protective equipment when operating, servicing, or when in the operating area of the equipment to help protect you from serious injury, including eye injury, inhalation of toxic fumes, burns, and hearing loss. This equipment includes but is not limited to:</p> <ul style="list-style-type: none"> • Protective eyewear • Clothing and respirator as recommended by the fluid and solvent manufacturer • Gloves • Hearing protection
	<p>SKIN INJECTION HAZARD High-pressure fluid from gun, hose leaks, or ruptured components will pierce skin. This may look like just a cut, but it is a serious injury that can result in amputation. Get immediate surgical treatment.</p> <ul style="list-style-type: none"> • Do not point gun at anyone or at any part of the body. • Do not put your hand over the spray tip. • Do not stop or deflect leaks with your hand, body, glove, or rag. • Close material shutoff valves when not spraying. • Follow Pressure Relief Procedure in this manual, when you stop spraying and before cleaning, checking, or servicing equipment.

Warnings

! WARNING

	<p>FIRE AND EXPLOSION HAZARD</p> <p>Flammable fumes, such as solvent and paint fumes, in work area can ignite or explode. To help prevent fire and explosion:</p> <ul style="list-style-type: none"> • Use equipment only in well ventilated area. • Eliminate all ignition sources; such as pilot lights, cigarettes, portable electric lamps, and plastic drop cloths (potential static arc). • Keep work area free of debris, including solvent, rags and gasoline. • Do not plug or unplug power cords, or turn power or light switches on or off when flammable fumes are present. • Ground all equipment in the work area. • Use only grounded hoses. • Hold gun firmly to side of grounded pail when triggering into pail. • If there is static sparking or you feel a shock, stop operation immediately. Do not use equipment until you identify and correct the problem. • Keep a working fire extinguisher in the work area.
	<p>PRESSURIZED ALUMINUM PARTS HAZARD</p> <p>Do not use 1,1,1-trichloroethane, methylene chloride, other halogenated hydrocarbon solvents or fluids containing such solvents in pressurized aluminum equipment. Such use can cause serious chemical reaction and equipment rupture, and result in death, serious injury, and property damage.</p>
	<p>EQUIPMENT MISUSE HAZARD</p> <p>Misuse can cause death or serious injury.</p> <ul style="list-style-type: none"> • Do not operate the unit when fatigued or under the influence of drugs or alcohol. • Do not exceed the maximum working pressure or temperature rating of the lowest rated system component. See Technical Data in all equipment manuals. • Use fluids and solvents that are compatible with equipment wetted parts. See Technical Data in all equipment manuals. Read fluid and solvent manufacturer's warnings. For complete information about your material, request MSDS forms from distributor or retailer. • Check equipment daily. Repair or replace worn or damaged parts immediately with genuine manufacturer's replacement parts only. • Do not alter or modify equipment. • Use equipment only for its intended purpose. Call your distributor for information. • Route hoses and cables away from traffic areas, sharp edges, moving parts, and hot surfaces. • Do not kink or over bend hoses or use hoses to pull equipment. • Keep children and animals away from work area. • Comply with all applicable safety regulations.
	<p>MOVING PARTS HAZARD</p> <p>Moving parts can pinch or amputate fingers and other body parts.</p> <ul style="list-style-type: none"> • Keep clear of moving parts. • Do not operate equipment with protective guards or covers removed. • Pressurized equipment can start without warning. Before checking, moving, or servicing equipment, follow the Pressure Relief Procedure in this manual. Disconnect power or air supply.
	<p>BURN HAZARD</p> <p>Equipment surfaces and fluid that's heated can become very hot during operation. To avoid severe burns, do not touch hot fluid or equipment. Wait until equipment/fluid has cooled completely.</p>

Warnings

Isocyanate Hazard

					
<p>Spraying materials containing isocyanates creates potentially harmful mists, vapors, and atomized particulates.</p> <p>Read material manufacturer's warnings and material MSDS to know specific hazards and precautions related to isocyanates.</p> <p>Prevent inhalation of isocyanate mists, vapors, and atomized particulates by providing sufficient ventilation in the work area. If sufficient ventilation is not available, a supplied-air respirator is required for everyone in the work area.</p> <p>To prevent contact with isocyanates, appropriate personal protective equipment, including chemically impermeable gloves, boots, aprons, and goggles, is also required for everyone in the work area.</p>					

To prevent exposing ISO to moisture:

- Always use a sealed container with a desiccant dryer in the vent, or a nitrogen atmosphere. **Never** store ISO in an open container.
- Keep the ISO lube pump reservoir filled with Graco Throat Seal Liquid (TSL), Part 206995. The lubricant creates a barrier between the ISO and the atmosphere.
- Use moisture-proof hoses specifically designed for ISO, such as those supplied with your system.
- Never use reclaimed solvents, which may contain moisture. Always keep solvent containers closed when not in use.
- Never use solvent on one side if it has been contaminated from the other side.
- Always park pumps when you shutdown.
- Always lubricate threaded parts with Part 217374 ISO pump oil or grease when reassembling.

Moisture Sensitivity of Isocyanates

Isocyanates (ISO) are catalysts used in two component foam and polyurea coatings. ISO will react with moisture (such as humidity) to form small, hard, abrasive crystals, which become suspended in the fluid. Eventually a film will form on the surface and the ISO will begin to gel, increasing in viscosity. If used, this partially cured ISO will reduce performance and the life of all wetted parts.



The amount of film formation and rate of crystallization varies depending on the blend of ISO, the humidity, and the temperature.

Warnings

Keep Components A and B Separate

CAUTION

To prevent cross-contamination of the equipment's wetted parts, never interchange component A (isocyanate) and component B (resin) parts. The gun is shipped with the A side on the left. The fluid manifold, fluid housing, side seal assembly, check valve cartridge, and mix chamber are marked on the A side.

Foam Resins with 245 fa Blowing Agents

New foam blowing agents will froth at temperatures above 90°F (33 °C) when not under pressure, especially if agitated. To reduce frothing, minimize preheating in a circulation system.

Changing Materials

- When changing materials, flush the equipment multiple times to ensure it is thoroughly clean.
- Always clean the fluid inlet strainers after flushing.
- Check with your material manufacturer for chemical compatibility.
- Most materials use ISO on the A side, but some use ISO on the B side.
- Epoxies often have amines on the B (hardener) side. Polyureas often have amines on the B (resin) side.

Section 1 - Installation: Introduction

Introduction

Before operating, maintaining or servicing any **GlasCraft** system, read and understand all of the technical and safety literature provided with **GlasCraft** products. If you do not have the proper or related manuals and safety literature for your **GlasCraft** system, contact your **GlasCraft** distributor or **GlasCraft, Inc.**

In this **GlasCraft** technical and safety publication, the following advisories will be provided where appropriate:



Information about the procedure in progress.



Is imperative information about equipment protection.



Indicates a hazardous situation that can result in minor or moderate injury.



Indicates a hazardous situation that can result in death or serious injury.



Indicates a hazardous situation that can result in electrical shock or serious injury.

The information in this document is intended only to indicate the components and their normal working relationship typical use. Each assembly should be directed by a **GlasCraft** distributor or made from the **GlasCraft** Assembly instructions provided.

This manual provides information for the assembly, operation, maintenance and service of this **GlasCraft** product as used in a typical configuration. While it lists standard specifications and procedures, some deviations may be found.

In order to provide our users with the most up-to-date technology possible, we are constantly seeking to improve products. If a technological change occurs after a product is on the market, we will implement that technology in future production and, if practical, make it available to current users as a retrofit, update or supplement. If you find a discrepancy between your unit and the available documentation, contact your **GlasCraft** distributor to resolve the difference. **GlasCraft, Inc.** reserves the right to change or modify this product as it deems necessary.

Careful study and continued use of this manual will provide a better understanding of the equipment and process, resulting in more efficient operation, longer trouble-free service and faster, easier troubleshooting.

Section 1 - Installation: Standard Equipment

Model - MH VR

Standard Equipment	
Part Number	Description
22300-XX	MH VR Dispensing System
SPGN-FS-02F	Probler P2 Gun• W/ Flat Spray Mixing Chamber
256626	Whip Hose Assembly
249588	High Pressure Heated Hose Assembly
17798-25	Air hose assembly
18101-01	1/4 in. x 1/4 in. Fitting
1017-00	1/4 in. x 1/4 in. Hose adapter
59934-04	Dioctyl Phthalate, 1 Qt.
GC-1300	System User Manual

Section 1 - Installation: Equipment Assembly

Optional Transfer Pump Installation

P/n: 17666-01

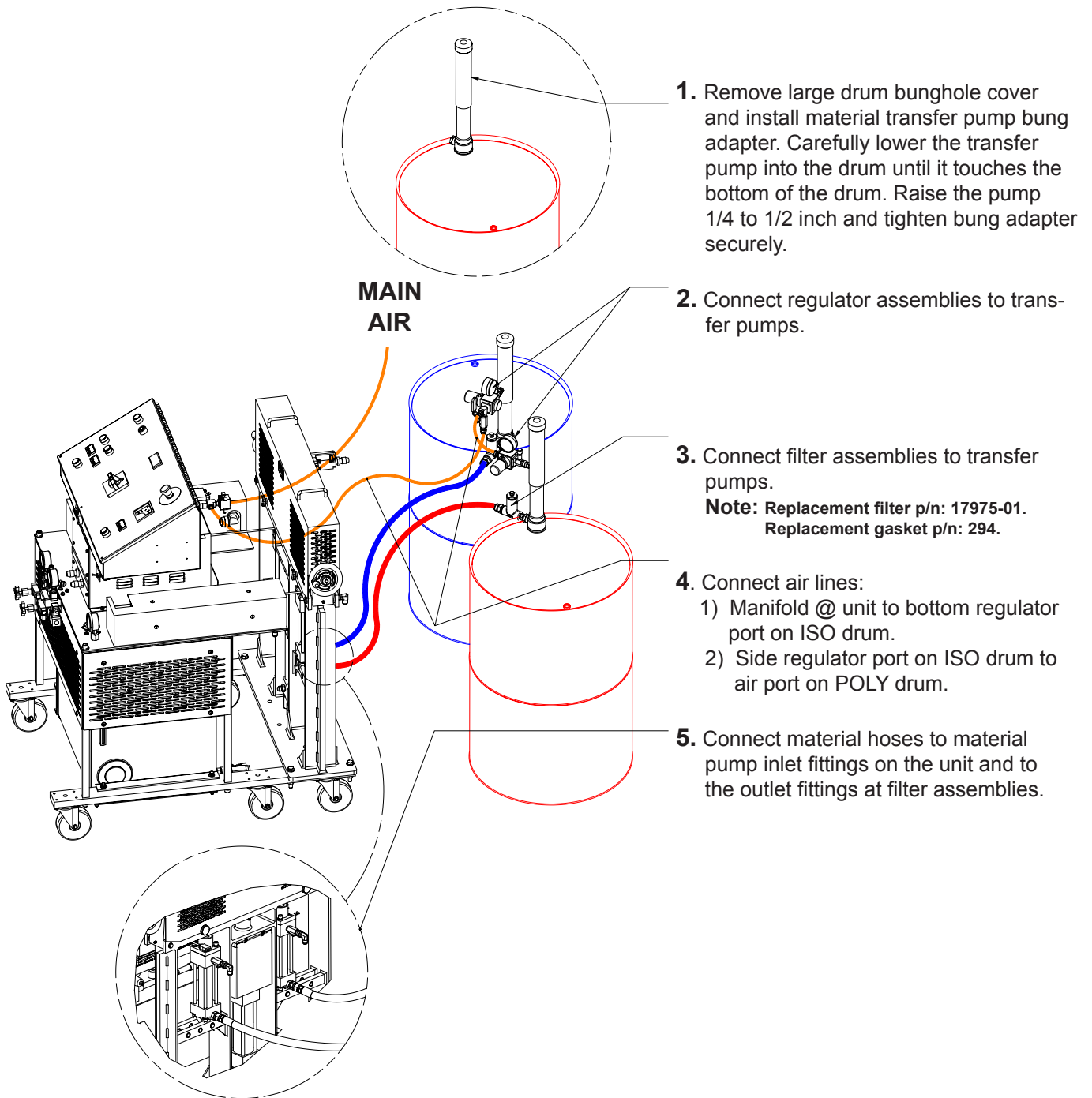

Optional Desiccant Dryer Kit

P/n: 23410-00 should be installed on the ISO material drum. Replacement cartridge p/n: 23409-00.

Section 1 - Installation: Equipment Assembly

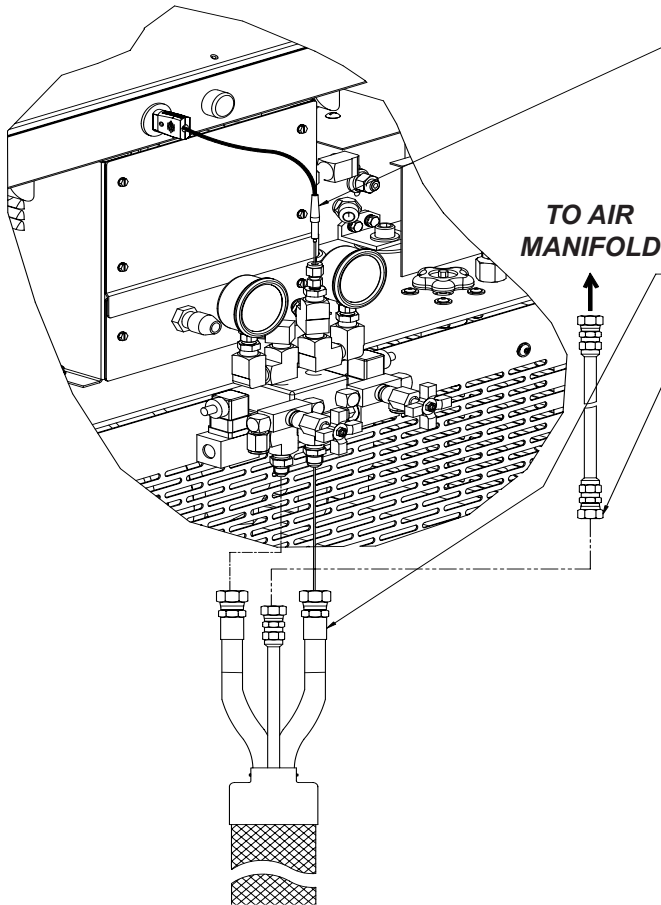

6. Install thermocouple at tee fitting.
 - a. Feed 12' line through hose.
 - b. Nut & Ferrules will lock into fitting.
 - c. Tighten nut 1-1/4 turns past finger tight.
 - d. Plug thermocouple into control box.

Note: When replacing thermocouple p/n 22074-00 use kit p/n: 21214-01.
7. Connect hose assembly, p/n: 22023-01 to the front of the unit. The fittings are sized differently and will attach only one way. (match like sized fittings).
8. Connect supplied trigger air line to the air line on the hose assembly.
9. Connect the electrical wires.
 - Ensure the wire ends are 5/8 in. (.625 mm) long. If they are not, use a sharp pair of scissors to strip all four wire ends to the correct length.

Strip Length

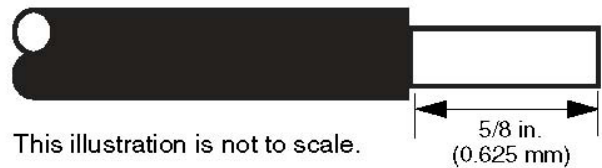

Be careful, do not cut or nick any copper strands. If more than five strands are cut or nicked, trim and re-strip the wires.

New hoses are pre-stripped to the correct length; remove the insulation to expose the bare wire.

10. Ensure the strip length is correct by fitting the ferrule over the exposed wire. The ferrule should be flush with the end of the wire.

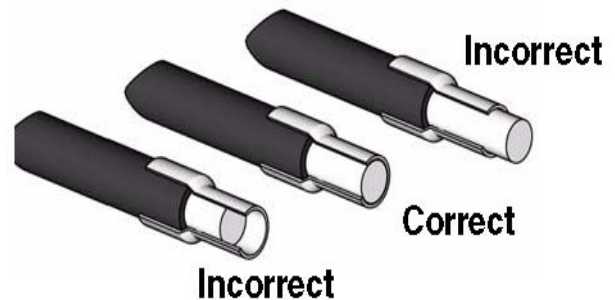

Section 1 - Installation: Equipment Assembly

 If the wire is short of the ferrule end, adjust the strip length accordingly. If bare is protruding from the ferrule, trim it flush to the end of the ferrule.

 To reach approximately 60 in.-lbs. (6.78 N•m), complete 4.5 revolutions with the hex wrench after the set screw contacts the ferrule.

11. Remove the ferrule and apply oxide inhibitor to the bare wire.
12. Reinsert the wire in the ferrule and apply more oxide inhibitor to the ferrule and wire end.

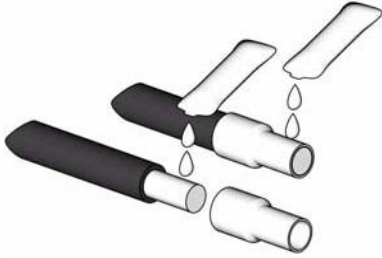

13. Pair the electrical wires as follows:

A-Hose to A-Hose
B-Hose to B-Hose

 When connecting the first hose to the proportioner, wire painting does not make a difference.

14. Insert one wire from the heated hose into the connector. Ensure that the ferrule is mating with the connector insert and attach the set screw. Torque the set screw to 60 in.-lbs. (6.78 N•m).

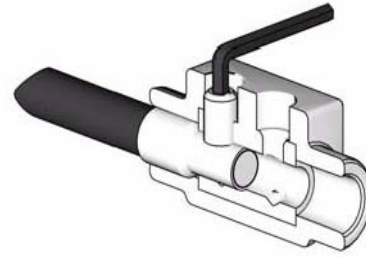
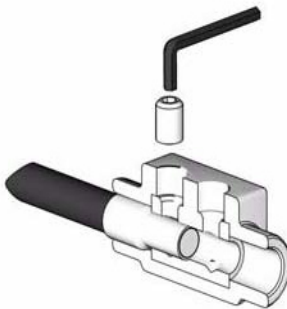

15. Repeat steps 21 through 24 for remaining.

 Re-torque all four set screws to 60 in.-lbs. (6.78 N•m). The set screws will be approximately flush with the connector.

16. Insert the cap plugs over the set screws.

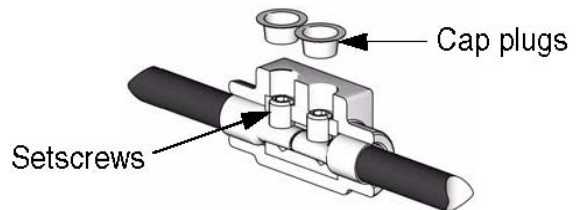

17. Repeat steps 21 through 26 for additional hoses.

Section 1 - Installation: Equipment Assembly

18. Add extra hose lengths if necessary.

Required Tools:

Opened - end wrenches - 3/4 in.

a. Lay hoses out straight.

b. Couple hoses together with supplied union fittings and tighten finger-tight.

c. • Hold crimp fitting hex (3/4 in.), and union fitting together, allowing the hose to hold its natural line.

- Using 3/4 in. wrenches to tighten swivel fitting to union, do not allow crimp fitting or union to turn. Repeat on opposite side of union.

This practice is required on all connection points.

1) Hose and machine

2) Hose and gun

3) Adding additional hose sections

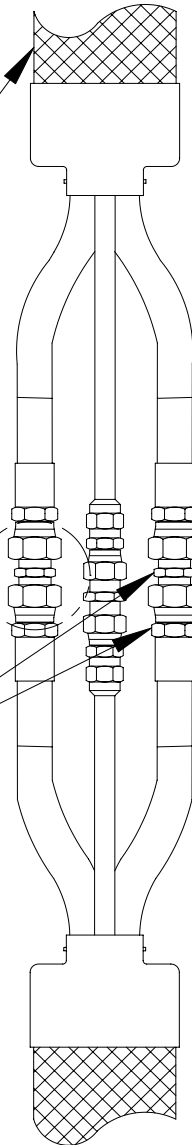

Section 1 - Installation: Equipment Assembly

19. Connect the supplied swivel fitting p/n 23825-00 to the trigger air line **before** attaching the hose assembly to the gun.
20. Connect hose assembly and the gun as shown. The fittings on the hose assembly are sized differently and will attach only one way.
21. Fluid and air connections between the system and gun should now be complete and **tight**.

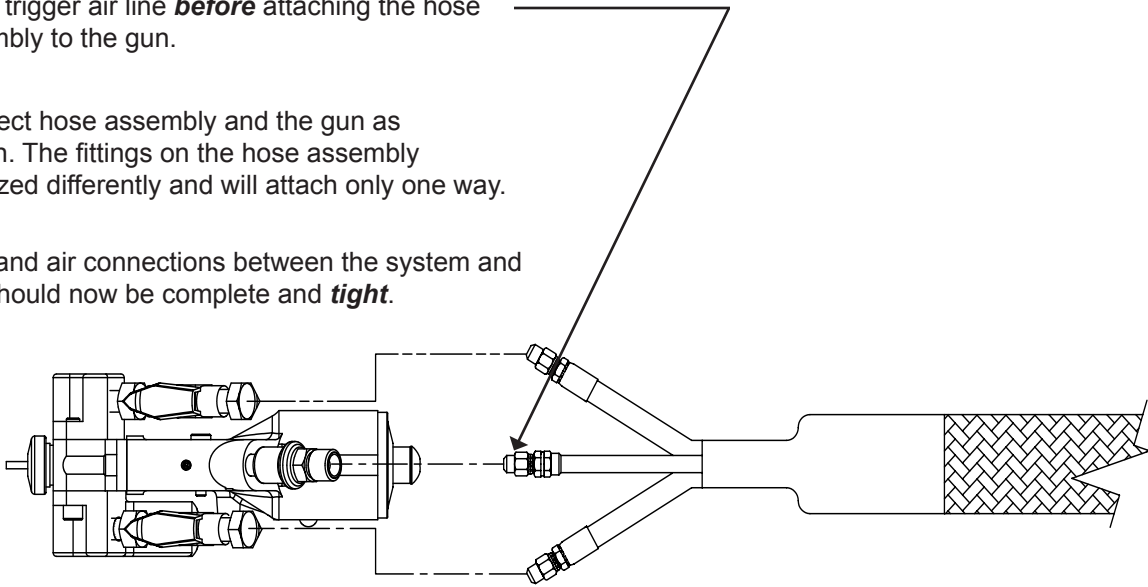

When Main Power to system console is on, the white and black wires in the console are **always live!** Disconnect or turn **off** Main Power source before opening console to make any repairs or before making any electrical repair of any type to the system.

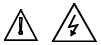

If you do not understand the electrical hook-up described above, consult your local GlasCraft distributor OR a qualified electrician.



Electrical connections must be checked on a periodic basis.

- 208/240 volt single phase
- L1 L2 GROUND
- 208/240 volt three phase
- L1 L2 L3 GROUND
- 380 volt three phase
- L1 (black)
- L2 (brown)
- L3 (black)
- L4 (blue)
- GROUND (green)

22. If more than 50 ft. of hose is used the transformer tap setting will need to be set for proper hose length. The sticker on the front cover will say which tap to move the wire to. **DO NOT MOVE THE COMMON LEG!**

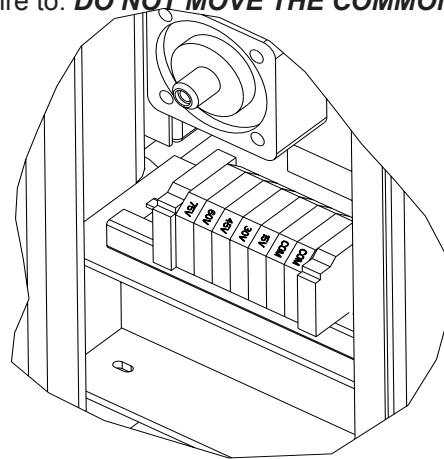

CONNECTIONS		HOSE LENGTH
	15V	50 FT
	30V	100 FT
	COM	150 FT
	45V	200 FT
(DO NOT MOVE)	60V	250 FT
	60V	250 FT
	75V	300 FT

Section 1 - Installation: Equipment Assembly

22. Fill the hydraulic power pack with proper fluid.

 The hydraulic pack tank is empty when shipped from GlasCraft. The tank **MUST** be filled before operation. **Tank Capacity: 20 GAL. / 75.5 Liter.**

 Recommended Hydraulic Fluid: ISO grade 32, 46, or 68. Fluids containing anti-wear additives are recommended for optimum service life.

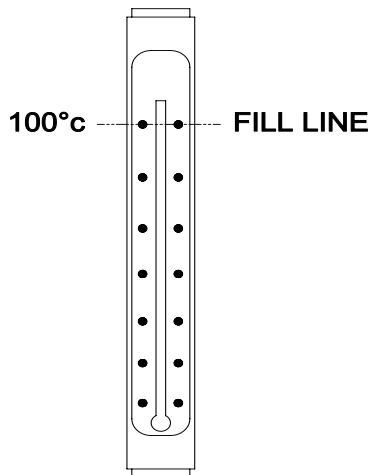
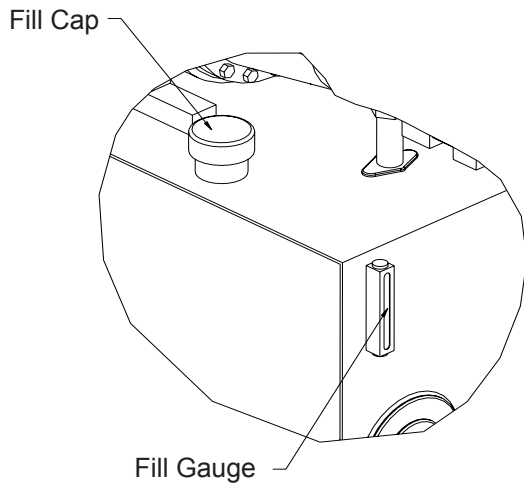

Section 2 - Operation: Start-Up Instructions

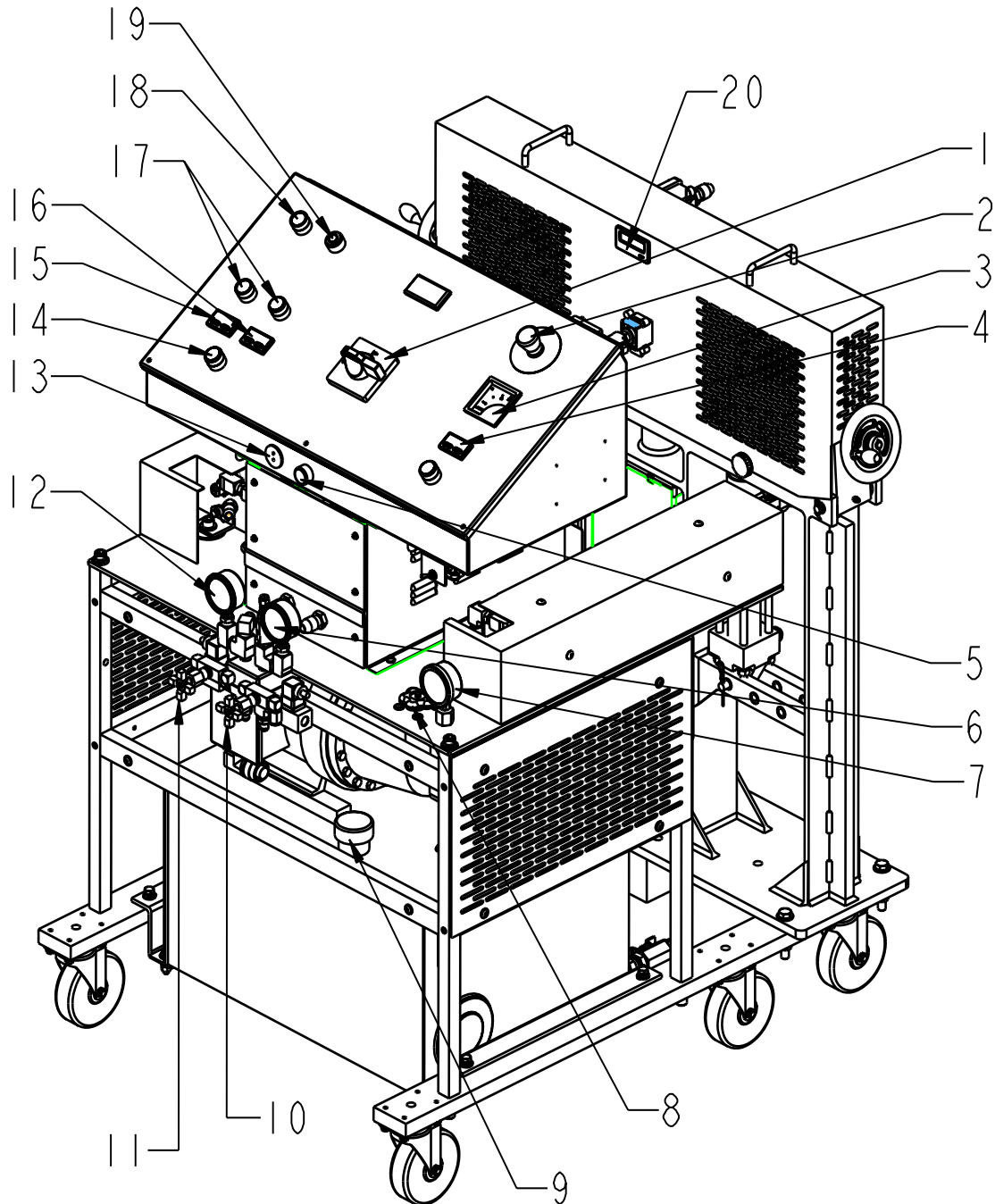

Section 2 - Operation: Start-Up Instructions

System Console

1	MAIN POWER SWITCH	Controls power and door; handle must point 1 to energize power, handle must point to 0 to open control box door. White pilot indicates when lighted, that the door interlock and power is on.
2	EMERGENCY STOP PUSH BUTTON	To stop all functions, push down on red button. To reset, turn handle on push button. All functions will remain off until the main power switch is switched off and back on.
3	AMMETER	An instrument for measuring amperes to the primary side of the hose's transformer.
4	HOSE TEMPERATURE CONTROLLER	Controls temperature of liquid inside the heated hoses. To set desired temperature, press the up or down button until you reach desired temperature. From this point, the temperature control is completely automatic.
5	WHITE PILOT LIGHT	Indicates power on.
6	POLY PRESSURE GAUGE	Indicates material pressure.
7	HYDRAULIC PRESSURE GAUGE	Indicates hydraulic pump pressure
8	HYDRAULIC PRESSURE KNOB	Increases or decreases hydraulic pressure. Turn clockwise to increase pressure. Turn counter-clockwise to decrease pressure.
9	HYDRAULIC OIL FILL PORT	Remove cap to fill tank with <i>recommended</i> hydraulic oil.
10	POLY DUMP VALVE	Removes pressure and material from POLY side.
11	ISO DUMP VALVE	Removes pressure and material from ISO side.
12	ISO PRESSURE GAUGE	Indicates material pressure.
13	HOSE THERMOCOUPLE OUTLET	Power outlet for hose thermocouple.
14	ON PUSH BUTTON	Powers the controller. It requires 10 seconds for the Controller to respond.
15	ISO TEMPERATURE CONTROLLER	Controls temperature of liquid inside ISO heater. To set desired temperature, press the up or down button until you reach desired temperature. From this point, the temperature control is completely automatic.
16	POLY TEMPERATURE CONTROLLER	Controls temperature of liquid inside the poly heater. To set desired temperature, Press the up or down button until you reach desired temperature. From this point, the temperature control is completely automatic.
17	OVER-PRESSURE RESET BUTTONS	When over-pressure is detected, the hydraulic power pack will be shut down, and will remain off until pressure is reduced and the push button is reset.
18	ON PUSH BUTTON	Powers the hydraulic power pack.
19	OFF PUSH BUTTON	Removes power to the hydraulic power pack.
20	COUNTER	Counts pumps cycles. (.084 GPC / .318 LPC)

Section 2 - Operation: Start-Up Instructions



Never leave machine unattended while system power is on or system is running.

System running is defined as: preheat cycle of the hose heat, primary heaters, or any pump operation.

Machine operators must be familiar with the component functions and operation of the machine.

If the transfer pumps can not move material adequately enough to properly prime the system it may be necessary to start the hydraulic power pack.

- a. Ensure hydraulic pressure knob is turned completely **counter clockwise**.

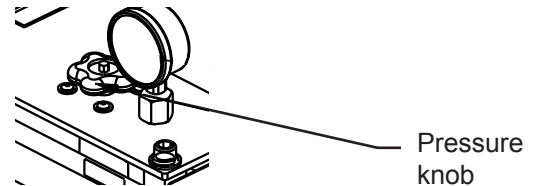

Pre-Operation Check List

- A. Check that all fittings are securely tight.
- B. Check electrical hook-up (qualified electrician recommended).
- C. Main power switch on Control Box should be switched to OFF position.



Do not place any part of the body in the path of the material spray.

Do not point the gun at or near other personnel.

Do not look into the Mixing Chamber orifice at any time.

Because of the hazardous materials used in this equipment, it is recommended that the operator use an air mask, goggles, protective clothing, and other safety equipment as prescribed by current regulations, recommendations of the chemical suppliers, and the laws in the area where the equipment is being used.

- b. Main air should be on to system manifold.

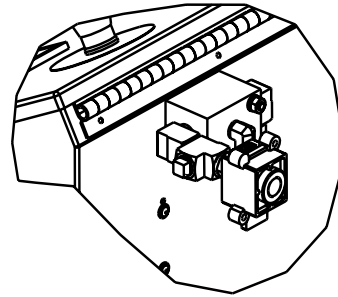

- c. Turn on hydraulic power pack.

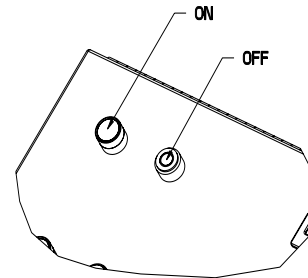

Initial Start-Up Procedure

With all material and air lines connected and power cable attached, the system is now ready for start-up.

NOTE: Refer to VR system user manual GC-1152 for pump placement and adjustment.

Filling The System

1. The system is now ready to be filled with material. With transfer pumps in place, adjust regulators on transfer pumps to 30-50 psi or until the pumps begin cycling, once the pumps begin loading up (cycle rate slows or stops) increase transfer pump air pressure to to 100 psi. to fill the system.

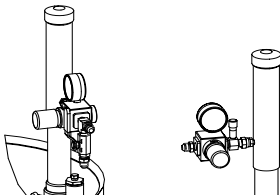

- d. Flip retract switch to "run" position.

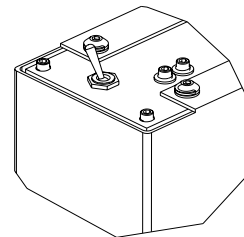

The pumps will begin cycling to completely prime the system

Section 2 - Operation: Start-Up Instructions

2. Remove ISO & POLY side blocks from gun.
MAKE SURE VALVES ARE OFF!

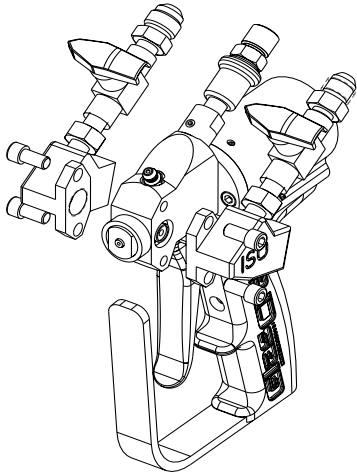

Before re-assembling Side Blocks, lubrication can be applied by dabbing a white lithium grease into holes inside of Gun Front Housing and wiping grease over Side-Block Seals. Grease will purge itself when air valve is turned on at Gun and Gun is triggered.

6. Clean and lubricate Side Blocks and Seals thoroughly and re-assemble on Gun. Make certain that Side Block Screws are tighten securely.
7. Refer to material manufacturers operating instructions for proper preparation of material, i.e, mixers, etc.
8. Turn main power Switch to ON position.

3. Place separate clean containers under each individual side block. Slowly open material valves (black arrow forward) on each side block to allow trapped air to escape the hose and material to flow into the containers until all air is purged from the material system.

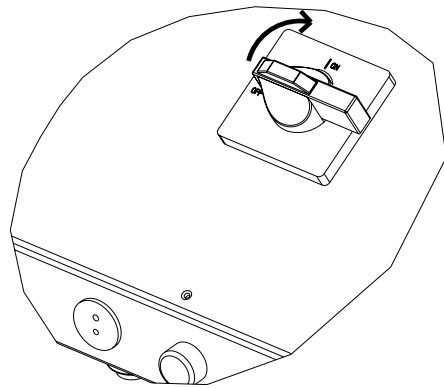
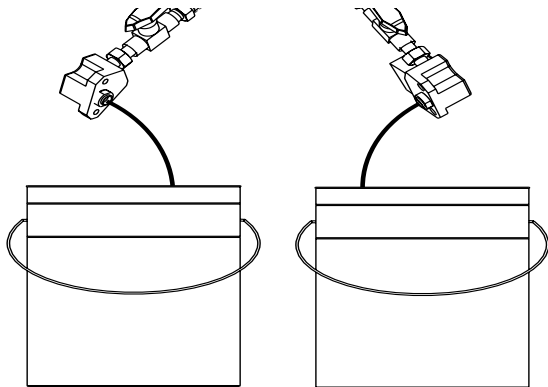

Remember to dispense one to two gallons of material to clear the system of grease and plasticizer that was used during factory testing.

4. Close manual material valves. Material pressure gauges should now register approximately equal pressure.
5. Dispose of waste material properly and in accordance with chemical suppliers instructions and local, state and federal regulations.

Section 2 - Operation: Start-Up Instructions

- 9. Turn on hose control:**
- a. Push in the green button.
 - b. Press either up or down arrow buttons on the controller until desired temperature setting is achieved.

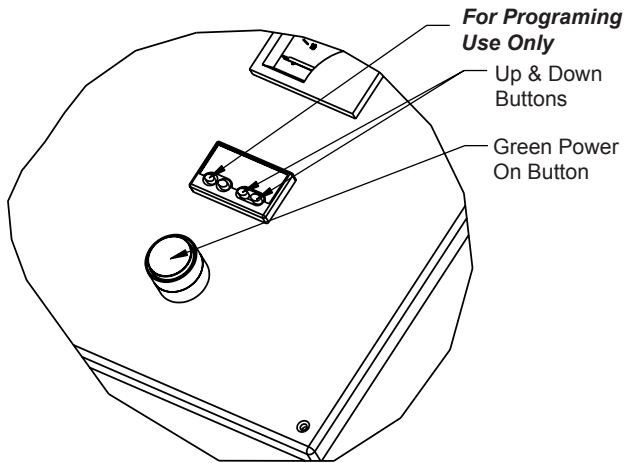

- 10. Turn on the ISO & POLY Heaters.**

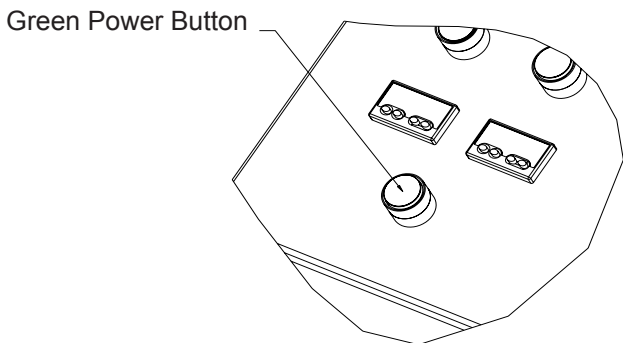



 Turn transfer pump air regulator on slowly. Pumps should cycle slowly until hoses are full of material.

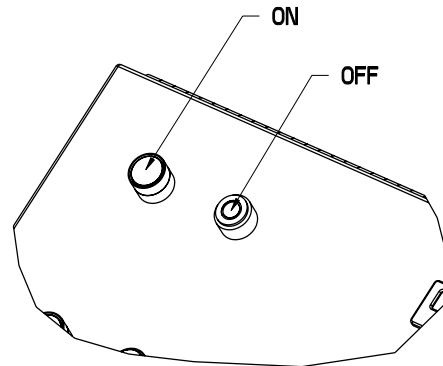

Straighten hose out flat, to avoid uneven heating and damage to internal wiring of the hose assembly.

- 11. Turn on Hydraulic Power Pack**



 Allow enough time for hose to warm up (approximately 30 minutes). Remember that the heated hose does not have a delta rating. The heated hose's function is to maintain the heat generated by the primary heaters during system operation, and preheat material during initial start-up. The hose should be set to maintain a temperature close to the set point of the primary heaters.

 To see the actual temperature of the liquid in the hose, push the blue button once and release. The actual temperature will then be displayed for 10 seconds.

- 12. Adjust temperature to desired setting. ISO and POLY controllers function exactly the same as the hose controller.**

 Allow enough time for the material to be heated (approximately 3-5 minutes).

- 13. Slowly adjust Hydraulic PRESSURE KNOB *clockwise* on the system to desired pressure.**

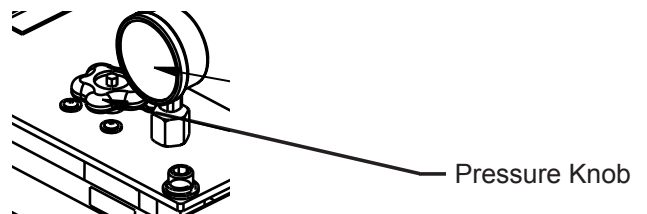

Section 2 - Operation: Start-Up Instructions

14. Turn purge air and material valves ON at the gun.

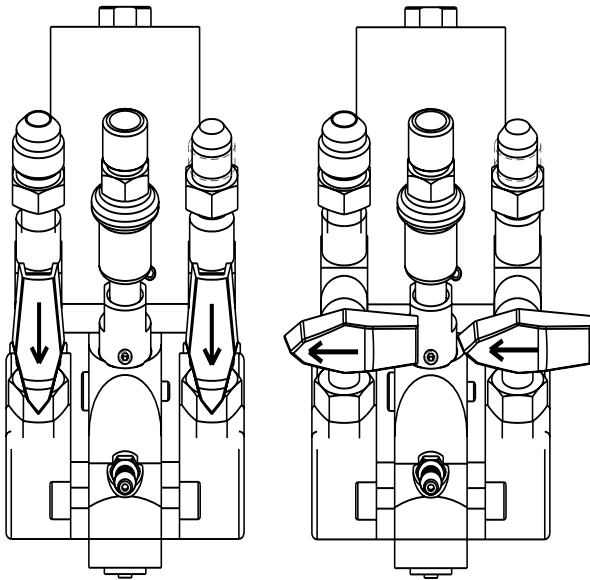

ON

OFF

16. Relieve any excess pressure by triggering the gun.

 The Emergency Stop Switch is located on the top right side of the Box Panel, when depressed, it will shut down the power to the system. To reset, turn handle on push button.

17. The system is now ready for operation.

15. If one side registers considerably more pressure than the other side, go to the high pressure side and bleed off some pressure by slightly opening the manual material valve on the side block over the container. Bleed pressure until both sides are approximately the same pressure.

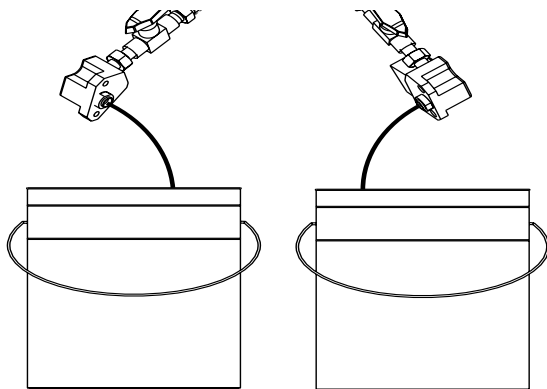

Material will dispense at high pressure. follow all safety precautions

Section 2 - Operation: Shut-Down Instructions

System Shut-Down

1. Flip “retract” switch from “run” position.

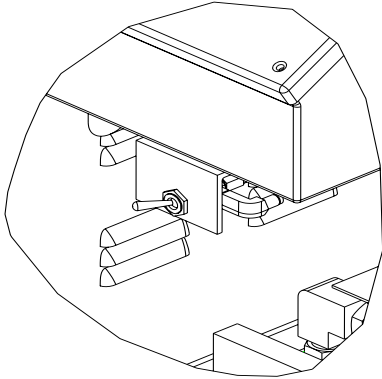

2. Trigger gun to send pumps into full downstroke.
3. Turn off hydraulic power pack.

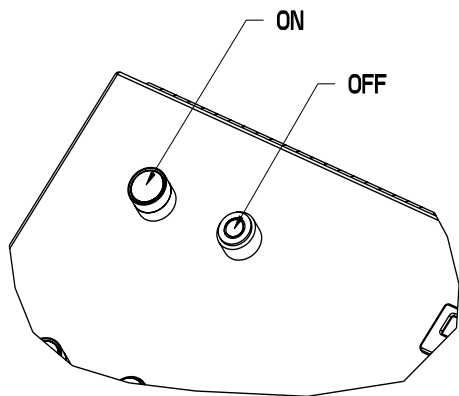

4. Turn off primary heaters.

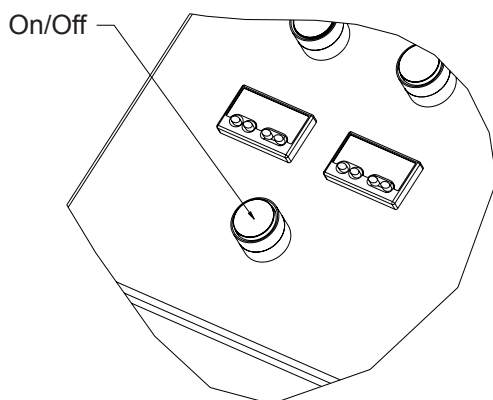

5. Turn main power switch off.

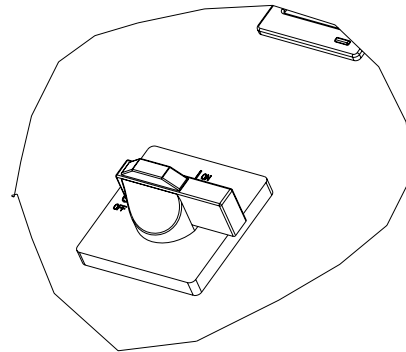

6. Refer to gun manual for proper Gun maintenance.
7. Reduce Hydraulic Pressure Knob setting to ZERO.
8. Visually inspect entire system for leaks.
9. Turn OFF System.



Leave 200-500 psi. on the material circuit gauges.

Storing The Hose

Coil the hose with a minimum diameter of 4', To avoid kinking and subsequent damage to the internal wiring of the hose assembly.

Section 2 - Operation: Daily Start-Up Instructions

1. Uncoil hose.
2. Check desiccant dryer beads to insure they are still purple and have not changed to pink.
3. Check and lub top of the fluid section.

Wipe off residual material and add a tablespoon of DBP or material supplier's recommended lubricant.

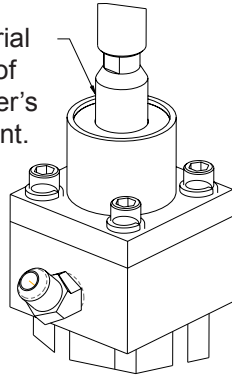

4. Check material screens at the gun and transfer pumps.
5. Start the drum mixer and it run to material suppliers specifications.
6. Turn on the hose controller and set the temperature according to material supplier's specifications.

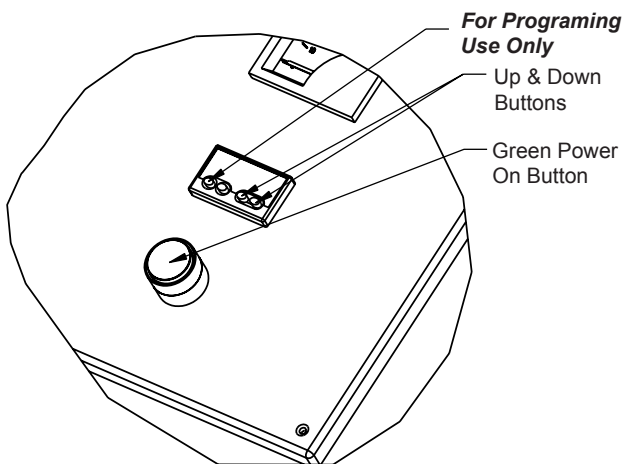

7. Once the hose temperature reaches desired set point, It's ok to turn on the primary heaters and set temperature to material suppliers specifications.

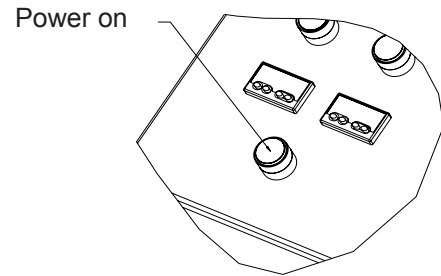

8. Depress yellow slide valve to open main air to gun and transfer pumps.

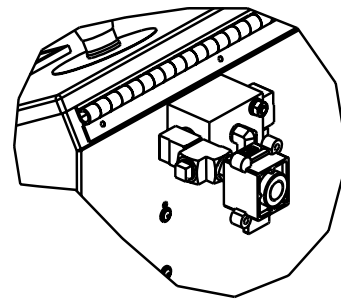

9. Flip retract switch to "run"

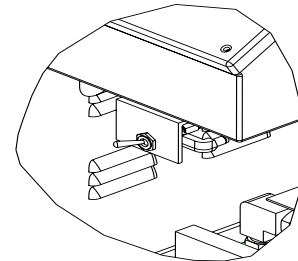

10. Increase Hydraulic pressure to desired pressure. Balance pressures if necessary.

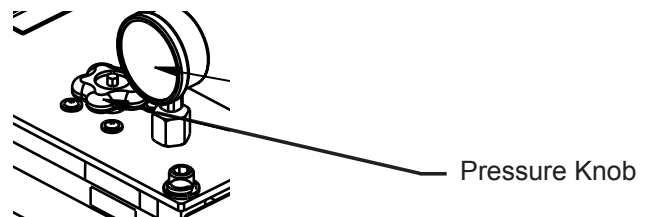

11. Perform probler / probler P2 side block seal integrity test.
12. Perform probler / probler P2 high-pressure ball valve test.

Section 3 - General Information: Assembly Drawings

22300-XX Unit Assembly

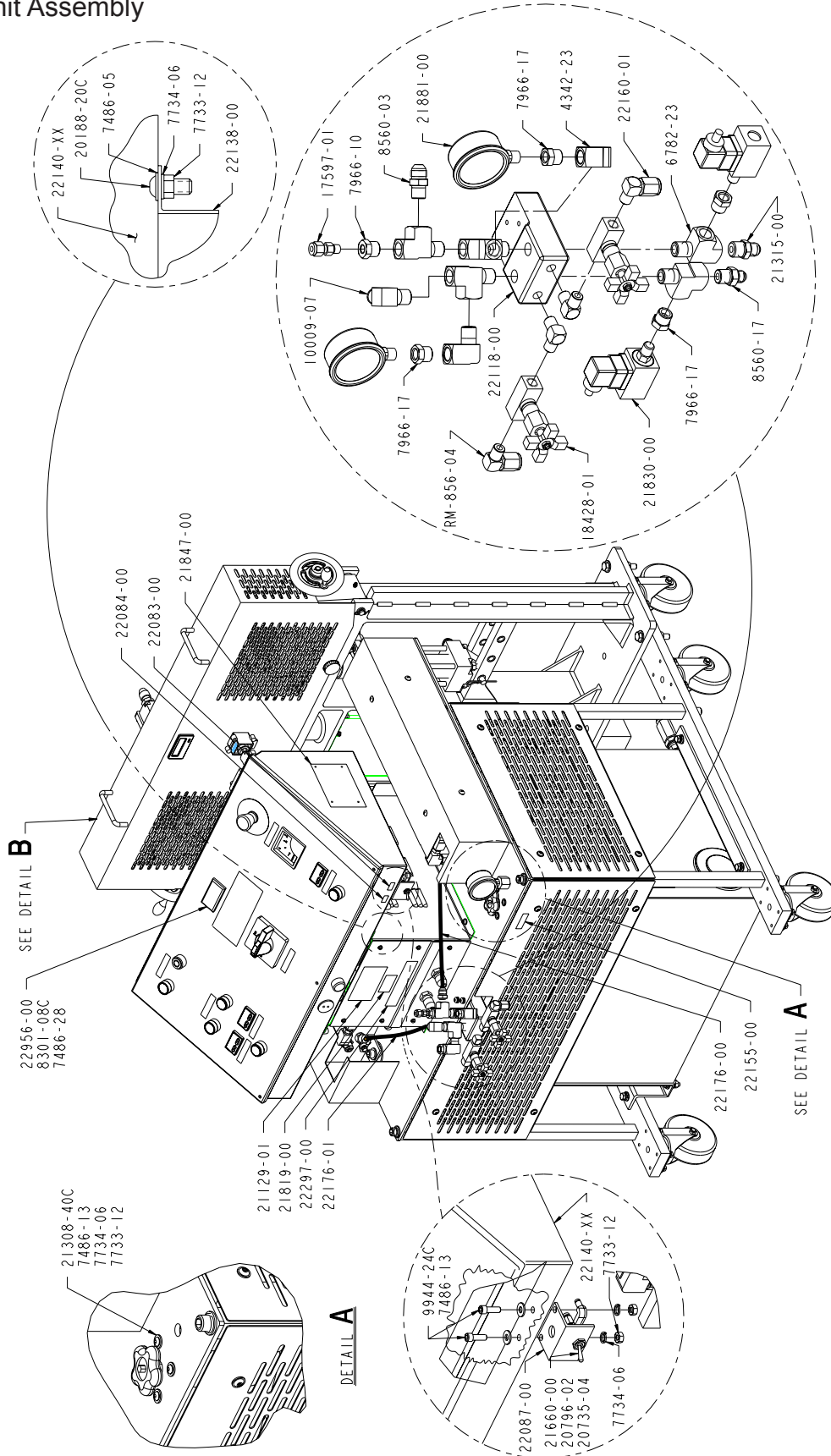

REVISION M

Section 3 - General Information: Assembly Drawings

22300-XX Unit Assembly

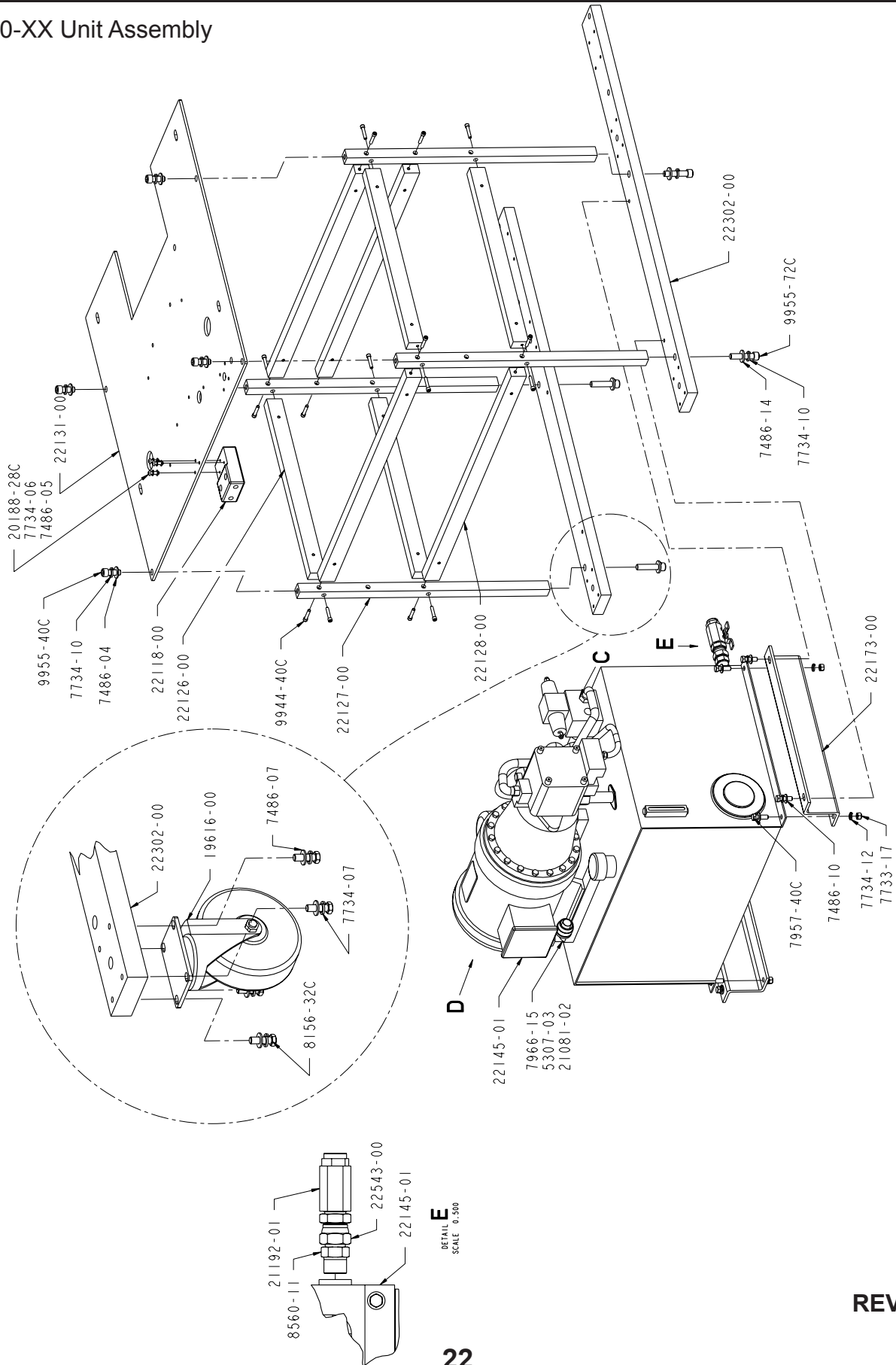

REVISION M

Section 3 - General Information: Assembly Drawings

22300-XX Unit Assembly

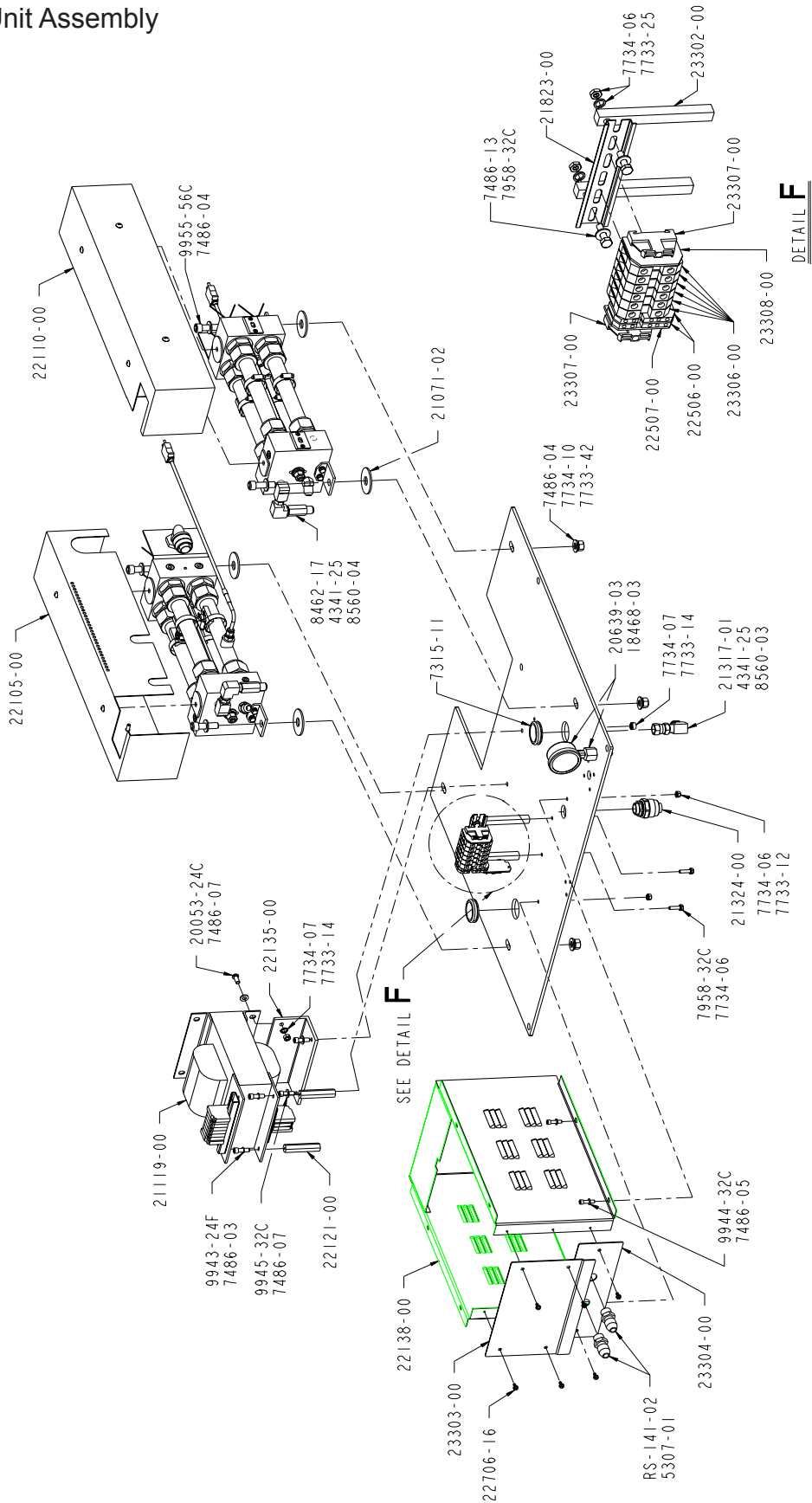

Section 3 - General Information: Assembly Drawings

22300-XX Unit Assembly

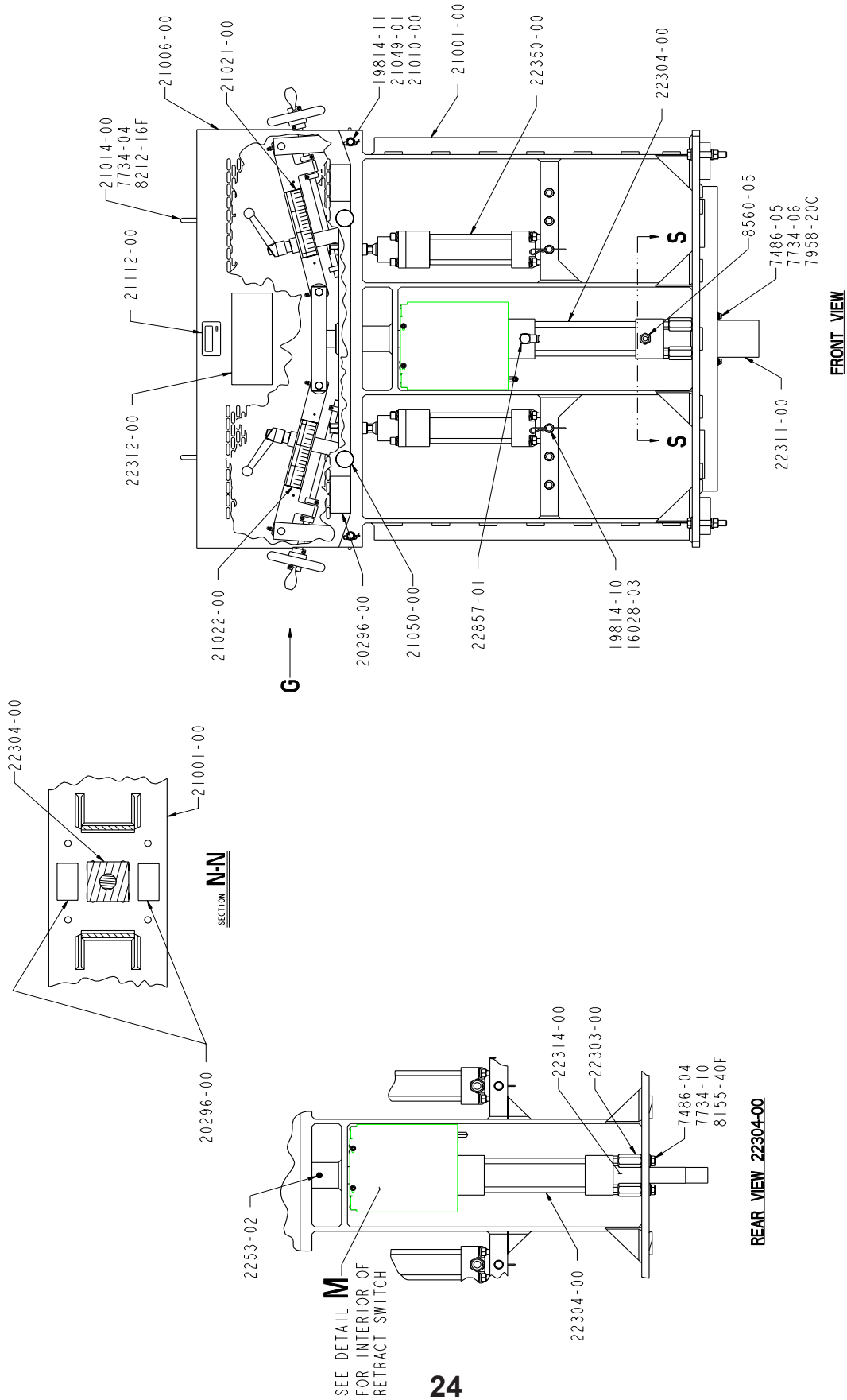

DETAIL B

REVISION M

Section 3 - General Information: Assembly Drawings

22300-XX Unit Assembly

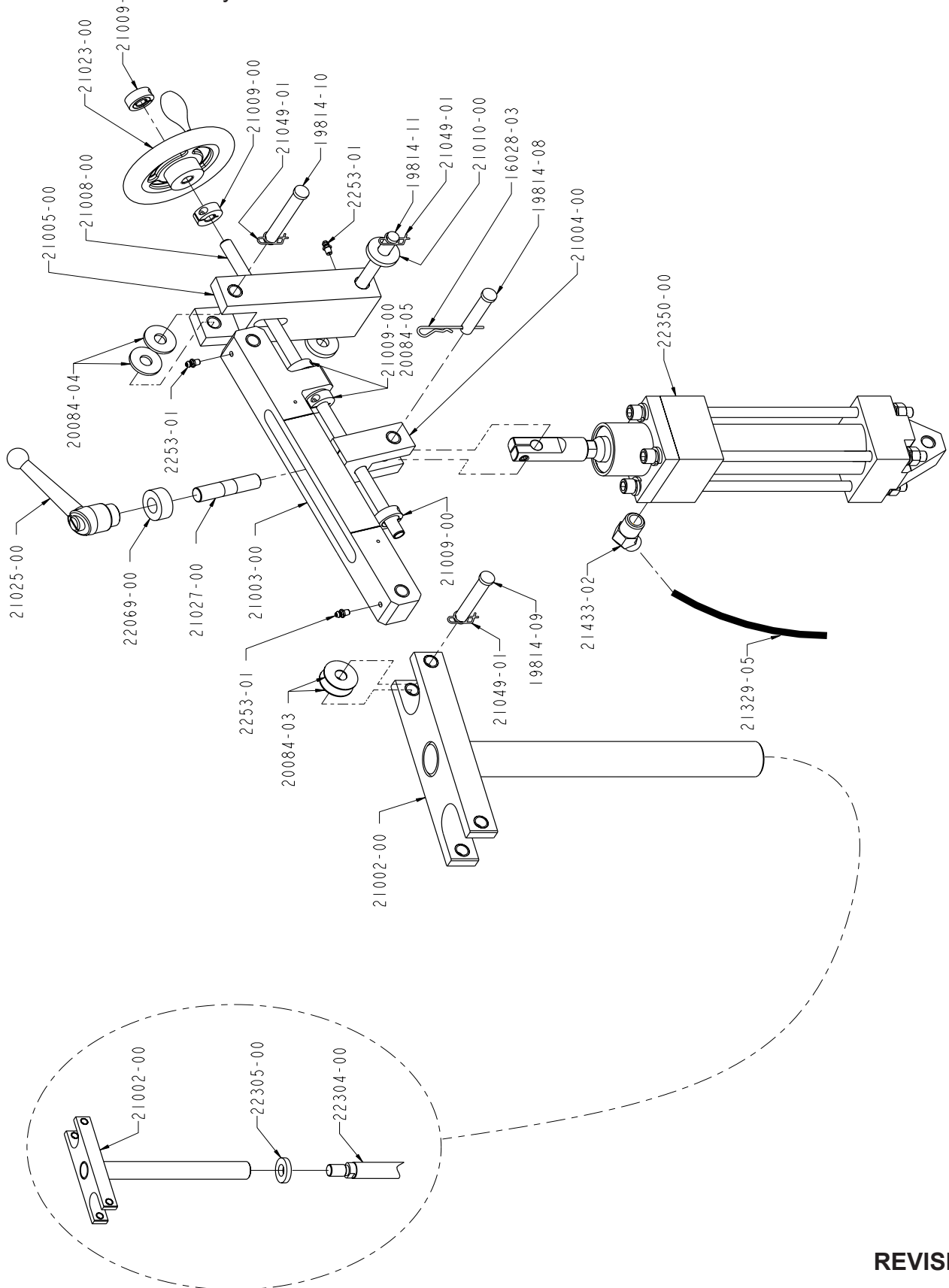

REVISION M

Section 3 - General Information: Assembly Drawings

22300-XX Unit Assembly

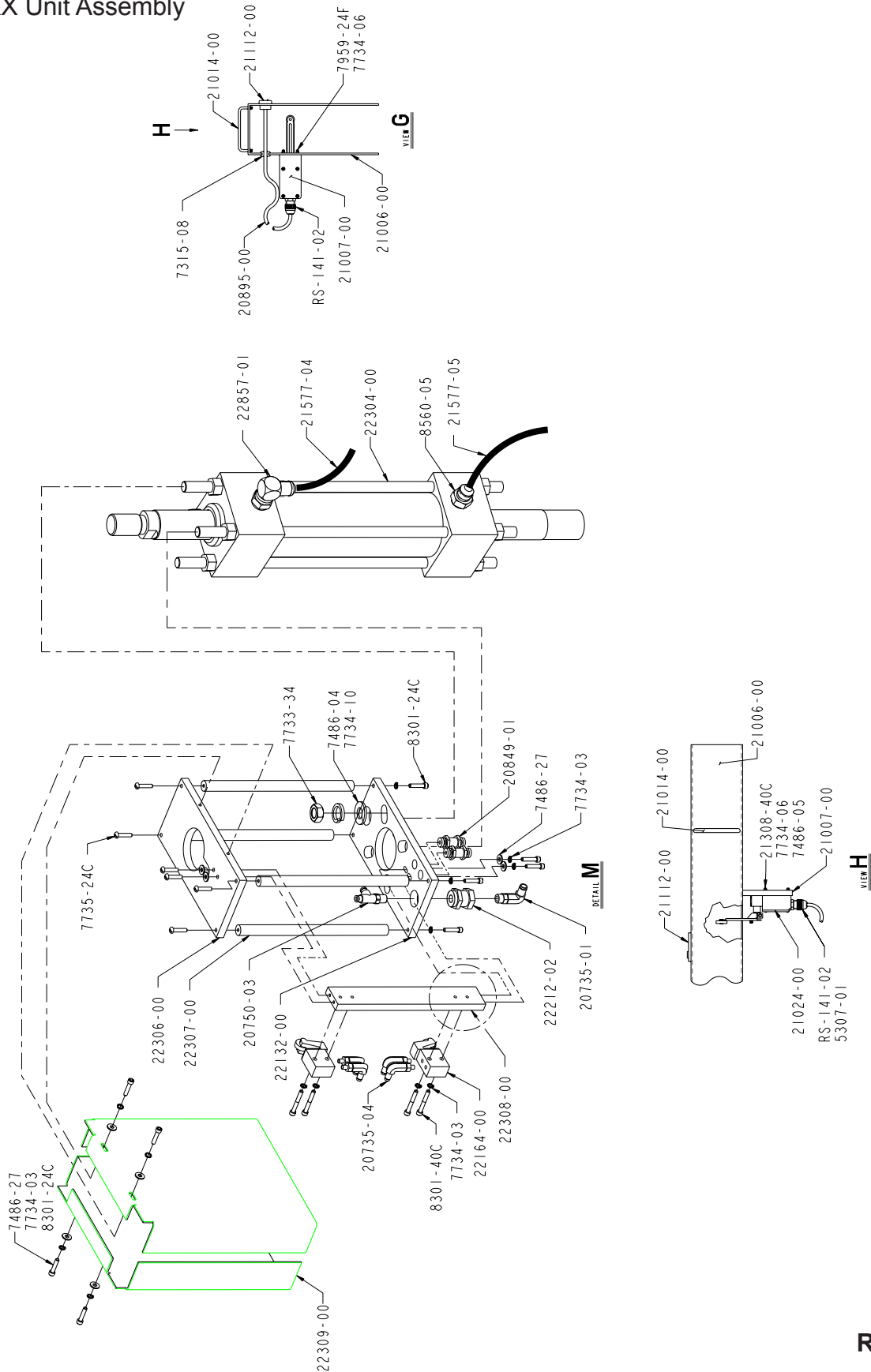

Section 3 - General Information: Assembly Drawings

22300-XX Unit Assembly

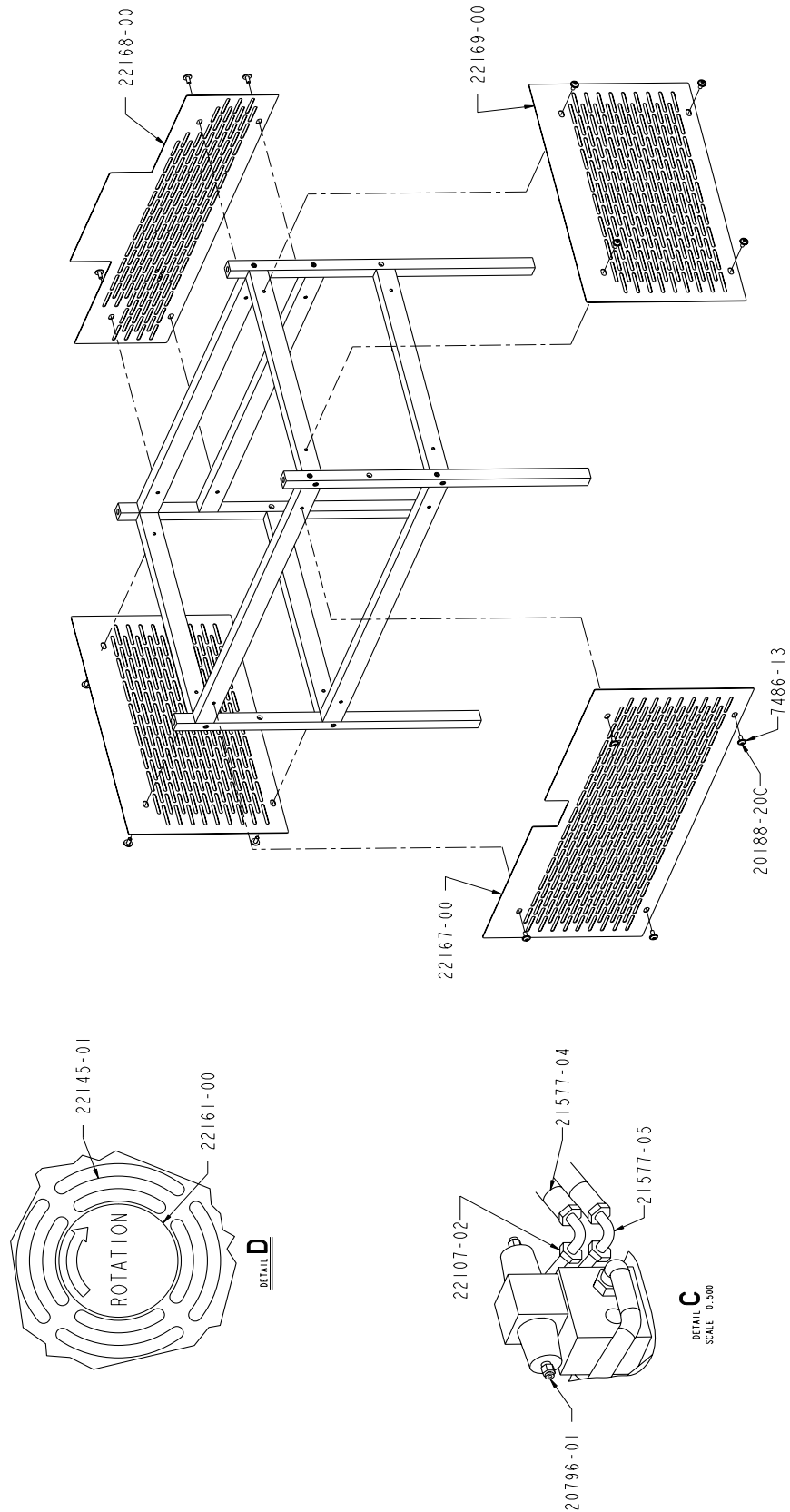

REVISION M

Section 3 - General Information: Assembly Drawings

22300-XX Unit Assembly

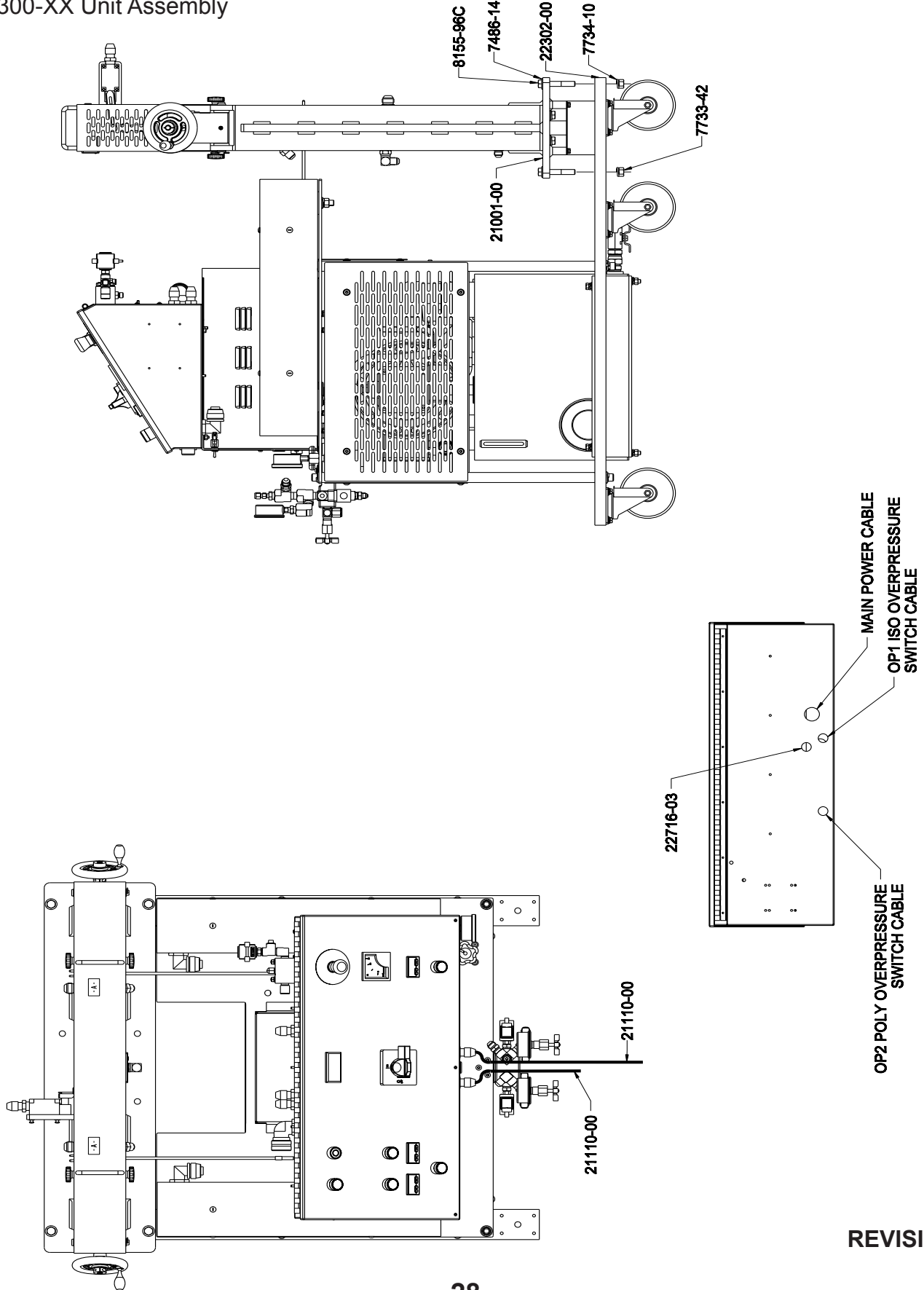

REVISION M

Section 3 - General Information: Assembly Drawings

22300-XX Unit Assembly

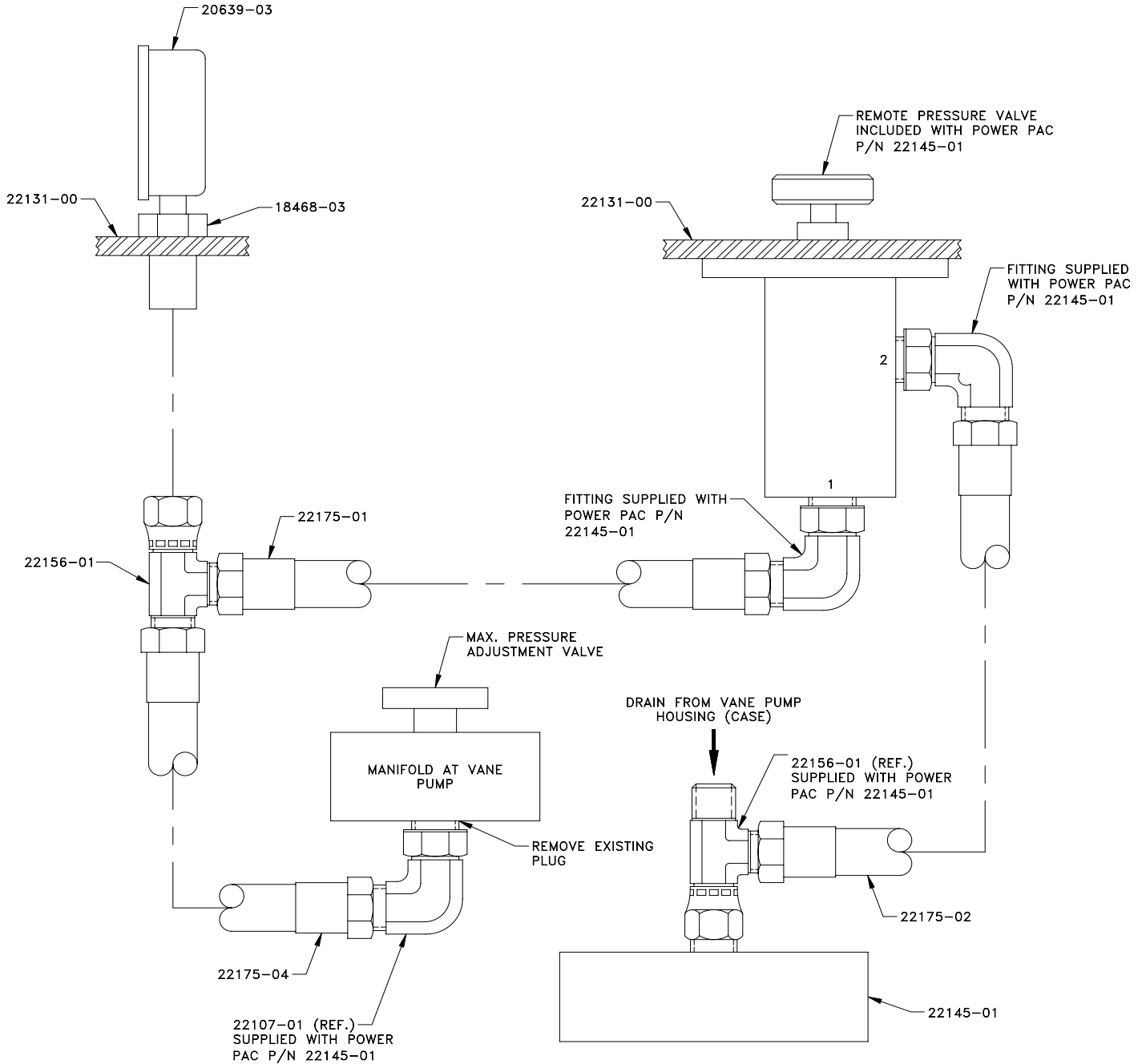

REVISION M

Section 3 - General Information: Assembly Drawings

22300-XX Unit Assembly

Part Number	Description
RM-856-04	ELBOW FITTING
RS-141-02	GRIP CORD
10009-04	ELBOW FITTING
10009-06	ELBOW FITTING
10009-07	ELBOW FITTING
13424-01	CABLE TIE
16028-03	HITCH PIN
17597-01	FITTING
18428-01	NEEDLE VALVE
18468-03	FITTING
19616-00	SWIVEL CASTER
19814-08	CLEVIS PIN
19814-09	CLEVIS PIN
19814-10	CLEVIS PIN
19814-11	CLEVIS PIN
20053-24C	MACHINE SCREW
20084-03	FLAT WASHER
20084-04	FLAT WASHER
20084-05	FLAT WASHER
20188-20C	MACHINE SCREW
20188-28C	MACHINE SCREW
20296-00	DECAL, PINCH POINT
20639-03	PRESSURE GAUGE
20732-03	TUBING
20735-01	ELBOW FITTING
20735-04	ELBOW FITTING
20750-03	TEE FITTING
20796-01	FITTING
20796-02	FITTING
20849-01	BULKHEAD FITTING
20895-00	CABLE
21001-00	VR FRAME
21002-00	GUIDE ROD
21003-00	PUMP DRIVE LINK
21004-00	PUMP ADAPTER
21005-00	BRACKET
21006-00	LINKAGE GUARD
21007-00	BRACKET
21008-00	SCREW
21009-00	LOCKING SHAFT
21010-00	WASHER
21014-00	HANDLE
21021-00	DECAL
21022-00	DECAL
21023-00	HAND WHEEL

Part Number	Description
21024-00	LIMIT SWITCH
21025-00	HANDLE
21027-00	STUD
21049-01	COTTER PIN
21050-00	KNOB
21071-02	WASHER
21081-02	CONNECTOR
21119-00	TRANSFORMER
21129-01	DECAL
21192-01	BALL VALVE
21308-40C	MACHINE SCREW
21315-00	CONNECTOR FITTING
21317-01	SWIVEL FITTING
21323-00	CONDUIT
21324-00	CONNECTOR
21329-05	MATERIAL HOSE
21433-02	ELBOW FITTING
21577-04	MATERIAL HOSE
21577-05	MATERIAL HOSE
21660-00	2-WAY CONTROL VALVE
21819-00	DECAL
21823-00	DIN RAIL
21830-00	OVER PRESSURE SWITCH
21847-00	CE PLATE
21881-00	PRESSURE GAUGE
22069-00	SPACER
22074-00	THERMOCOUPLE
22083-00	DECAL
22084-00	DECAL
22087-00	BRACKET
22105-00	ISO HEATER ASSEMBLY
22107-02	ELBOW FITTING
22110-00	POLY HEATER ASSEMBLY
22112-01	WIRE CONNECTOR
22118-00	MOUNTING BLOCK
22121-00	TRANSFORMER STANDOFF
22126-00	SIDE FRAME SUPPORT
22127-00	VERTICAL FRAME SUPPORT
22128-00	FRONT FRAME SUPPORT
22131-00	MOUNTING PLATE
22132-00	BOTTOM CHANGEVER PLATE
22135-00	TRANSFORMER MOUNTING PLATE
22138-00	TRANSFORMER COVER

Section 3 - General Information: Assembly Drawings

22300-XX Unit Assembly

Part Number	Description
22140-XX	CONTROL BOX ASSEMBLY
22145-01	HYDRAULIC MOTOR
22155-00	DECAL
22156-01	TEE FITTING
22160-01	PIPE CAP
22161-00	DECAL
22164-00	DIRECTIONAL CONTROL VALVE
22167-00	MOTOR COVER
22168-00	MOTOR COVER
22169-00	MOTOR COVER
22173-00	SUPPORT BRACKET
22175-01	MATERAIL HOSE ASSEMBLY
22175-02	MATERIAL HOSE ASSEMBLY
22175-04	MATERIAL HOSE ASSEMBLY
22176-00	MATERIAL HOSE ASSEMBLY
22176-01	MATERIAL HOSE ASSEMBLY
22212-02	BULKHEAD FITTING
22297-00	DECAL
22302-00	BRACKET
22303-00	STANDOFF
22304-00	CYLINDER ASSEMBLY
22305-00	SWITCH
22306-00	CHANGEVER PLATE
22307-00	STANDOFF
22308-00	BRACKET
22309-00	CHANGEVER GUARD
22311-00	SHAFT GUARD
22312-00	DECAL
22314-00	SHAFT GUARD
22350-00	V.R ASSEMBLY
22506-00	TERMINAL
22507-00	TERMINAL COVER
22509-01	CONTROL CABLE
2253-01	LUBE FITTING
2253-02	LUBE FITTING
22543-00	FITTING
22706-16	MACHINE SCREW
22716-03	HOLE PLUG
22857-01	ELBOW FITTING
22956-00	HOLE COVER
23302-00	STANDOFF
23303-00	TOP TRANSFORMER PANEL COVER
23304-00	BOTTOM TRANSFORMER PANEL COVER
23306-00	TERMINAL
23307-00	TERMINAL
23308-00	END BARRIER

Part Number	Description
3795-00	TERMINAL LUG
3800-08	WIRE
3923-02	SPIRAL WRAP
4341-25	ELBOW FITTING
4342-23	ELBOW FITTING
5307-01	CONDUIT NUT
5307-03	CONDUIT NUT
6782-23	TEE FITTING
7315-08	RUBBER GROMMET
7315-11	RUBBER GROMMET
7361-00	TERMINAL LUG
7486-03	WASHER
7486-04	WASHER
7486-05	WASHER
7486-07	WASHER
7486-10	WASHER
7486-13	WASHER
7486-14	WASHER
7486-27	WASHER
7486-28	WASHER
7733-12	NUT
7733-14	NUT
7733-17	NUT
7733-25	NUT
7733-42	NUT
7734-03	LOCK WASHER
7734-04	LOCK WASHER
7734-06	LOCK WASHER
7734-07	LOCK WASHER
7734-10	LOCK WASHER
7734-12	LOCK WASHER
7735-24C	MACHINE SCREW
7957-40C	MACHINE SCREW
7958-20C	MACHINE SCREW
7958-32C	MACHINE SCREW
7959-24F	MACHINE SCREW
7966-10	BUSHING
7966-15	BUSHING
7966-17	BUSHING
8155-40F	MACHINE SCREW
8155-96C	MACHINE SCREW
8156-32C	MACHINE SCREW
8212-16F	MACHINE SCREW
8301-08C	MACHINE SCREW
8301-24C	MACHINE SCREW

Section 3 - General Information: Assembly Drawings

22300-XX Unit Assembly

Part Number	Description
8301-40C	MACHINE SCREW
8462-17	PIPE NIPPLE
8560-03	FITTING
8560-04	FITTING
8560-05	FITTING
8560-11	FITTING
8560-17	FITTING
8846-03	WIRE
8846-08	WIRE
9704-03	TUBING
9943-24F	MACHINE SCREW
9944-24C	MACHINE SCREW
9944-32C	MACHINE SCREW
9944-40C	MACHINE SCREW
9945-32C	MACHINE SCREW
9955-40C	MACHINE SCREW
9955-56C	MACHINE SCREW
9955-72C	MACHINE SCREW

Section 3 - General Information: Sub Assembly Drawings

22140-XX Control Box Assembly

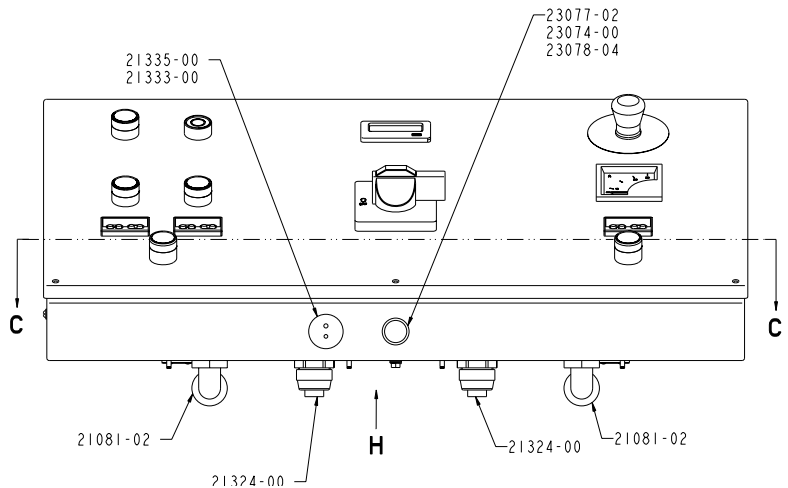
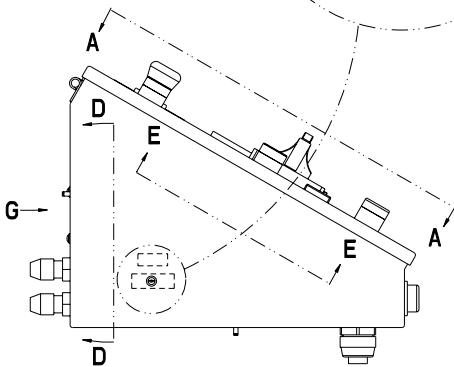
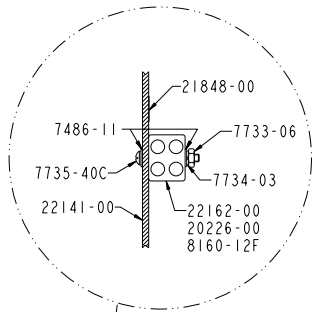
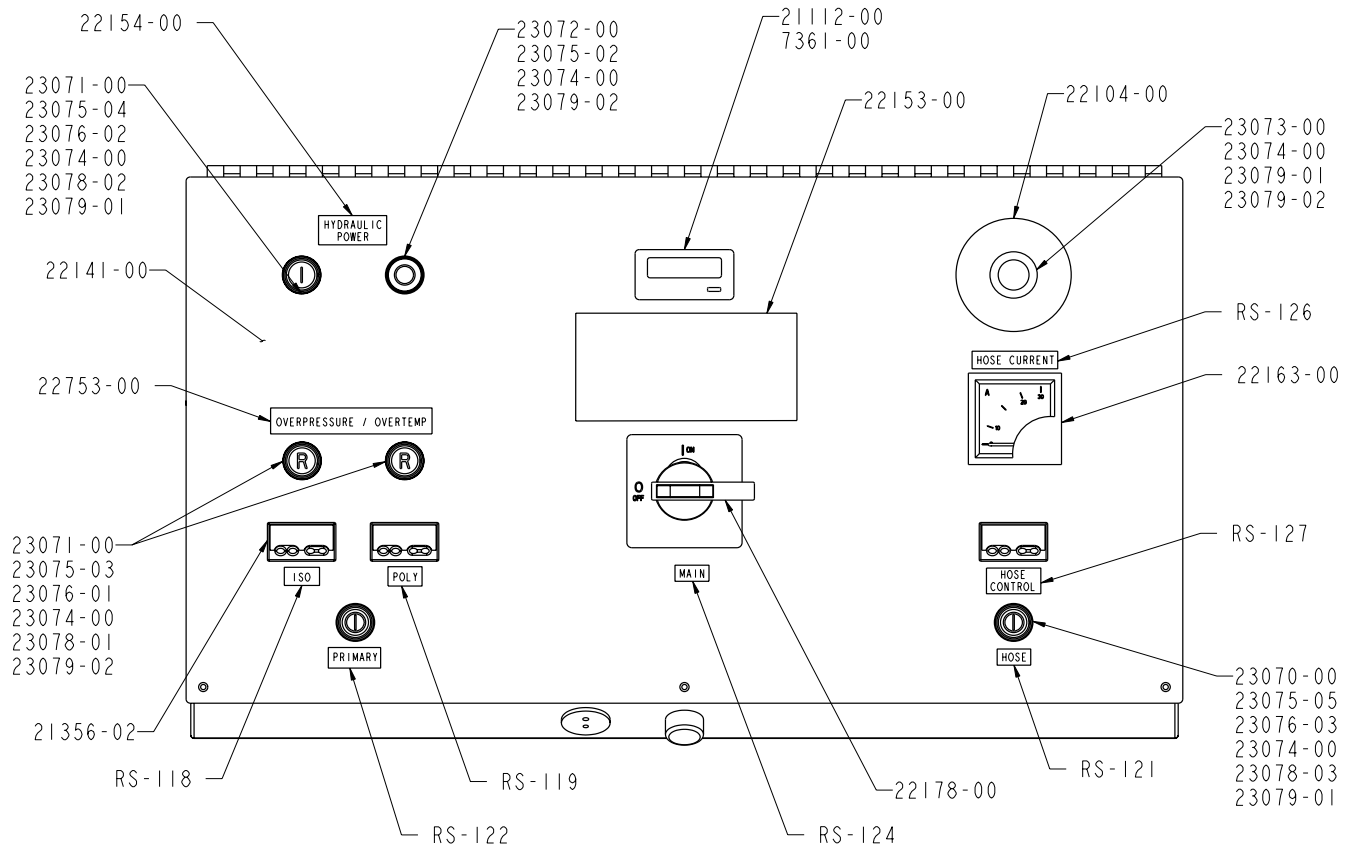

Section 3 - General Information: Sub Assembly Drawings

22140-XX Control Box Assembly

GLAS CRAFT P/N	PHASE					POWER CABLE
22140-02	230V 3 PHASE 5 HP 60 HZ	22171-01	22174-01	22157-00 (3) 22158-00 (6)	T4-161-01 5307-03	T4-163-04
22140-03	380V 3 PHASE 5 HP 50 HZ	22171-02	22174-02	22157-00 (4) 22158-00 (8)	T4-161-03 5307-03	22718-01

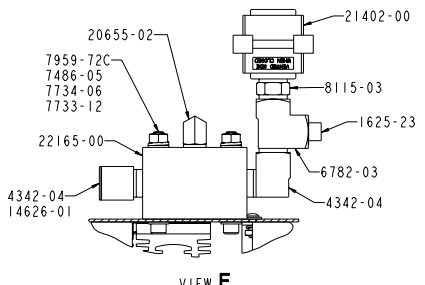
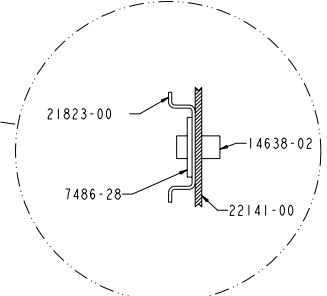
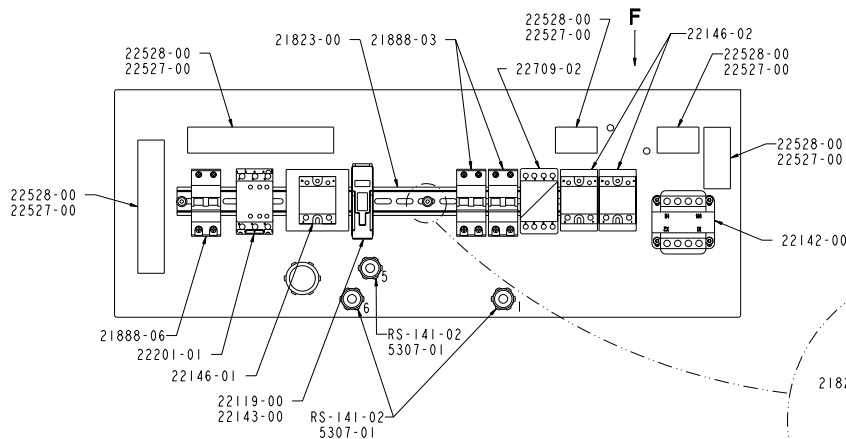
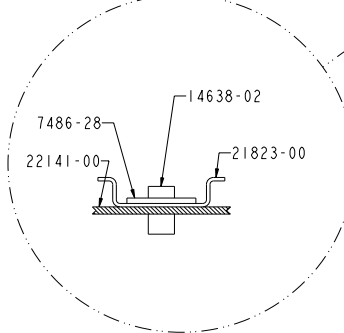
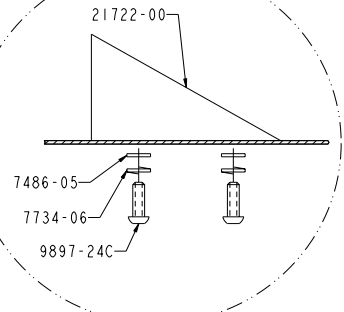
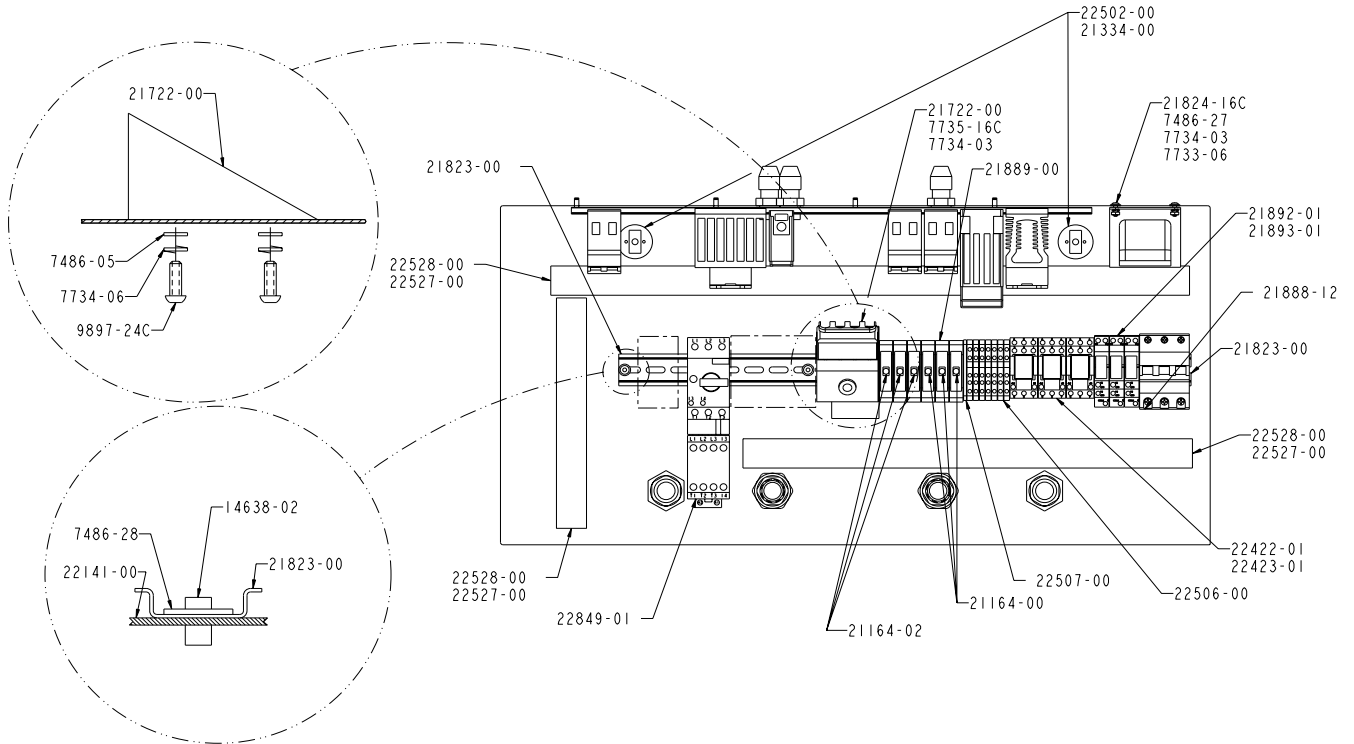

Section 3 - General Information: Sub Assembly Drawings

22140-XX Control Box Assembly

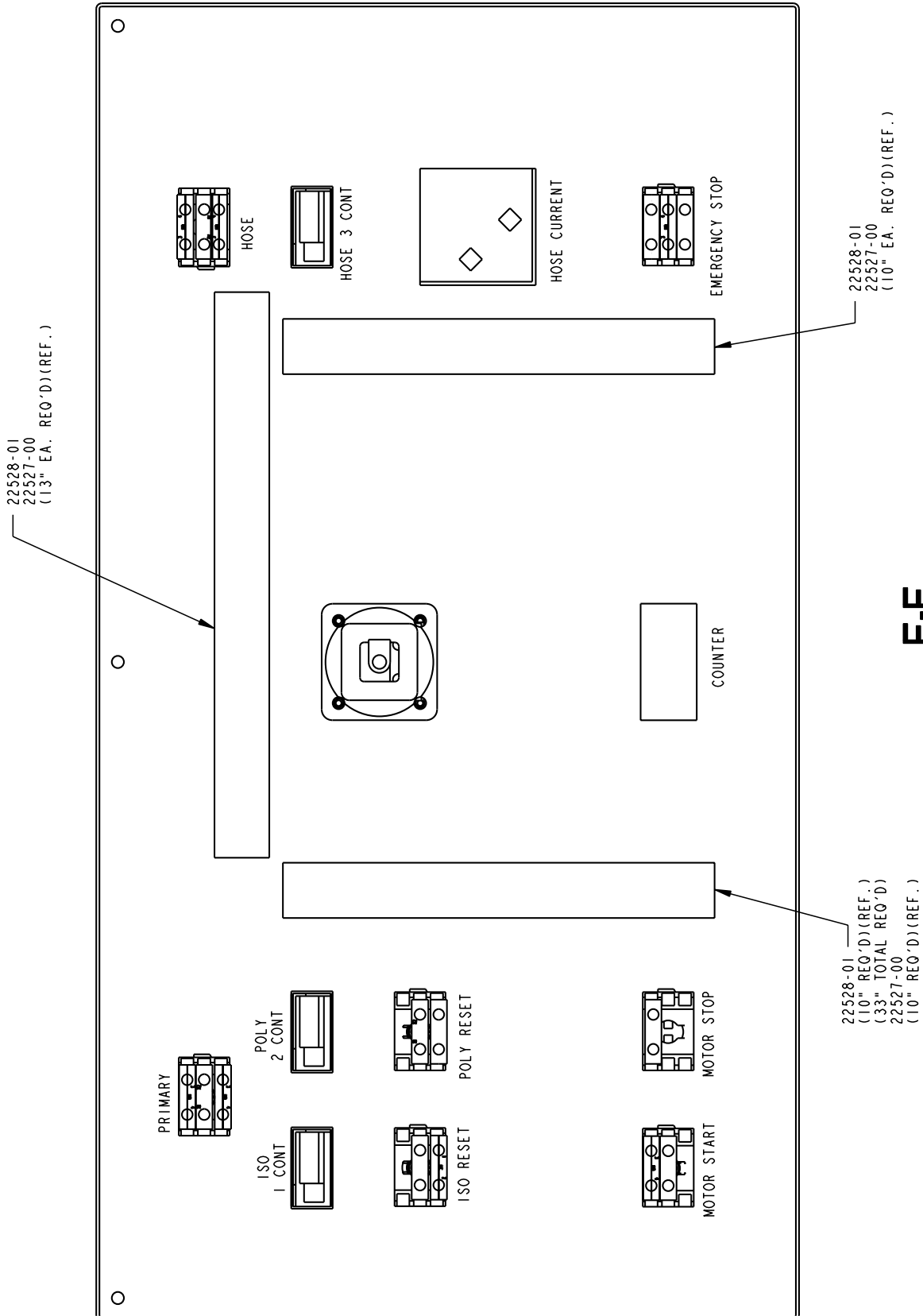

SECTION E-E

Section 3 - General Information: Sub Assembly Drawings

22140-XX Control Box Assembly

Part Number	Description	Qty.
13424-01	CABLE TIE	100
14626-01	FITTING	1
14638-02	RIVET	8
1625-23	PIPE PLUG	1
17883-08	#8 WIRE	
19510-01	TONGUE RING	5
20226-00	SET SCREW	1
20372-00	RELIEF VALVE	1
20655-02	ELBOW FITTING	1
20895-00	CABLE	5
21081-02	CONNECTOR	2
21110-00	#6 WIRE	
21112-00	LCD COUNTER	1
21150-00	TERMINAL LUG	6
21164-00	FUSE	3
21164-02	FUSE	3
21324-00	PLASTIC CONDUIT	2
21333-00	THERMOCOUPLE-GRADE WIRE	
21334-00	THERMOCOUPLE-GRADE WIRE	
21335-00	CIRCULAR PANEL JACK	1
21356-02	CONTROLER	3
21402-00	LOCKOUT VALVE	1
21722-00	MOUNTING BRACKET	1
21823-00	DIN RAIL	3.67
21824-16C	SCREW	4
21830-00	HIGH PRESSURE SWITCH	2
21848-00	PE DECAL	1
21888-03	CIRCUIT BREAKER	2
21888-06	CIRCUIT BREAKER	1
21888-12	CIRCUIT BREAKER	1
21889-00	FUSEHOLDER	6
21892-01	FINDER RELAY	3
21893-01	SOCKET RELAY	3
22104-00	EMERGENCY STOP DECAL	1
22119-00	FUSE BLOCK	1
22141-00	CONTROL BOX	1
22142-00	TRANSFORMER	1
22143-00	FUSE	1
22146-01	SOLID STATE RELAY	1
22146-02	SOLID STATE RELAY	2
22153-00	MH DECAL	1
22154-00	HYDRAULIC POWER DECAL	1
22162-00	CONDUCTOR CONNECTOR	1
22163-00	AMMETER	1

Part Number	Description	Qty.
22165-00	SPOOL VALVE	1
22166-06	#6 BLUE WIRE	
22166-08	#8 BLUE WIRE	
22166-12	#12 BLUE WIRE	
22166-18	#18 BLUE WIRE	
22178-00	POWER SWITCH	1
22201-01	MECHANICA CONTACTOR	1
22422-01	RELAY	3
22423-01	RELAY SOCKET	3
22502-00	CIRCULAR PANEL JACK	2
22506-00	TERMINAL	7
22507-00	TERMINAL END COVER	1
22527-00	WIRING DUCT COVER	9.125
22528-00	WIRING DUCT	6.375
22528-01	WIRING DUCT	2.75
22709-02	MECHANICAL CONTACTOR	1
22753-00	OVERPRESSURE DECAL	1
22849-01	CONTROLLER	1
23070-00	PUSHBUTTON	2
23071-00	PUSHBUTTON	3
23073-00	PUSHBUTTON	1
23074-00	COUPLING PLATE	8
23075-02	"O" INSCRIPTION CAP	1
23075-03	"R" INSCRIPTION CAP	2
23075-04	"I" INSCRIPTION CAP	1
23075-05	"I/O" INSCRIPTION CAP	2
23076-01	YELLOW CAP	2
23076-02	CLEAR CAP	1
23076-03	GREEN CAP	2
23077-02	WHITE PILOT LIGHT	1
23078-01	YELLOW LED	2
23078-02	WHITE LED	1
23078-03	GREEN LED	2
23078-04	WHITE LED	1
23079-01	OPEN CONTACT BLOCK	6
23079-02	CLOSED CONTACT BLOCK	5
3201	PLASTIC LUG RING	5
3800-08	COPPER WIRE	
3923-02	SPIRAL WRAP	1.5
4342-04	ELBOW FITTING	2
5307-01	CONDUIT NUT	3
6782-03	TEE FITTING	1
7208-02	#10 WIRE NUT	4
7208-04	#16 WIRE NUT	4

Section 3 - General Information: Sub Assembly Drawings

22140-XX Control Box Assembly

Part Number	Description	Qty.
7361-00	TERMINAL	7
7486-05	FENDER WASHER	6
7486-11	WASHER	2
7486-27	WASHER	4
7486-28	WASHER	8
7733-06	HEX NUT	5
7733-12	HEX NUT	2
7734-03	LOCK WASHER	7
7734-06	LOCK WASHER	4
7735-16C	SCREW	2
7735-40C	SCREW	1
7750-04	COPPER WIRE	
7959-72C	SCREW	2
8115-03	FITTING	1
8160-12F	SET SCREW	4
8846-03	YELLOW/GREEN COPPER WIRE	
8846-08	BLACK COPPER WIRE	
8847-08	BLACK INS. COPPER WIRE	
9897-24C	SCREW	2
RS-118	ISO DECAL	1
RS-119	POLY DECAL	1
RS-121	HOSE DECAL	1
RS-122	PRIMARY DECAL	1
RS-124	MAIN DECAL	1
RS-126	HOSE CURRENT DECAL	1
RS-127	HOSE CONTROL DECAL	1
RS-141-02	STRAIGHT GRIP CORD	3

Section 3 - General Information: Sub Assembly Drawings

22140-XX System Generic Ladder Schematic

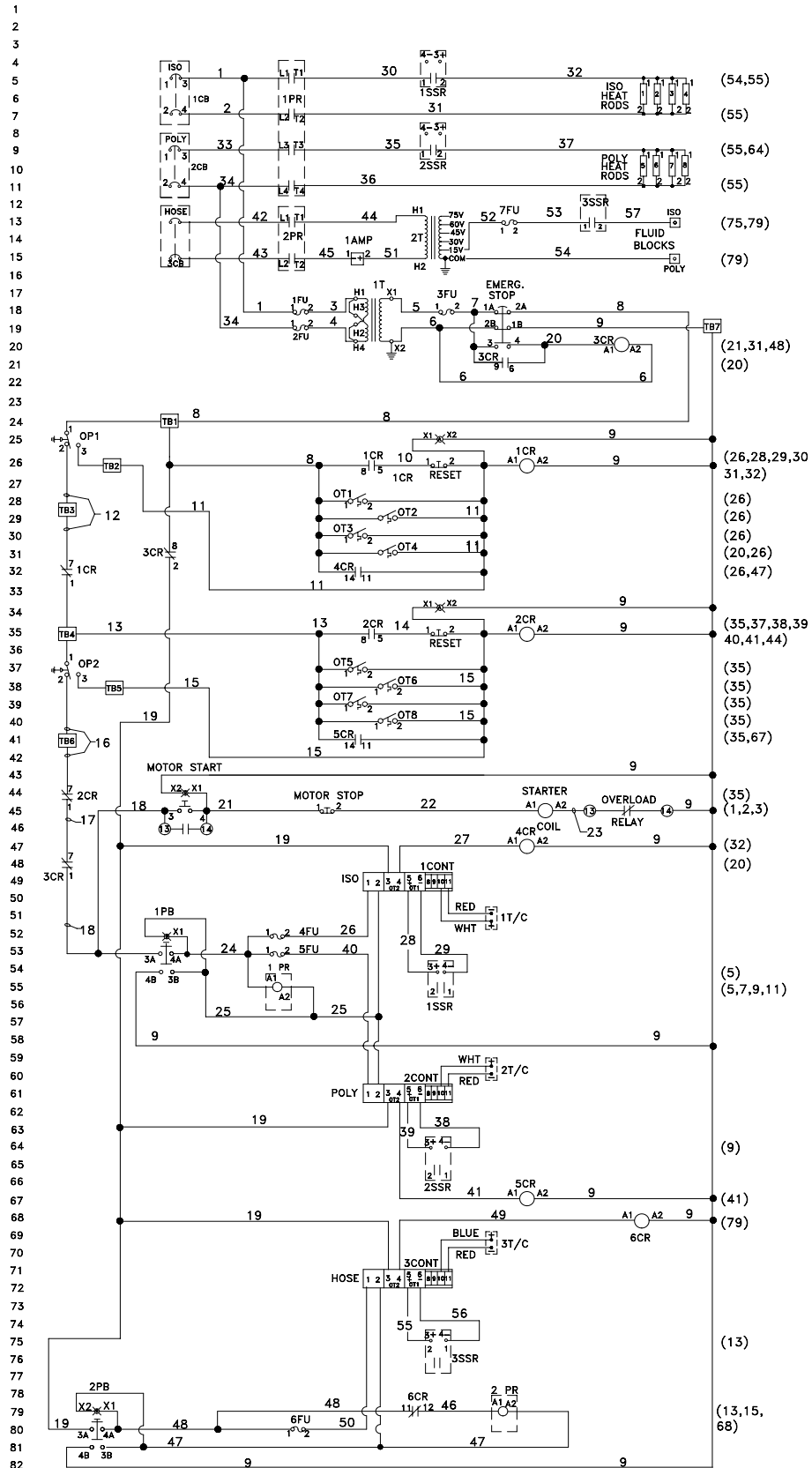

Section 3 - General Information: Sub Assembly Drawings

22140-02 System 220 Volt 3 Phase Schematic

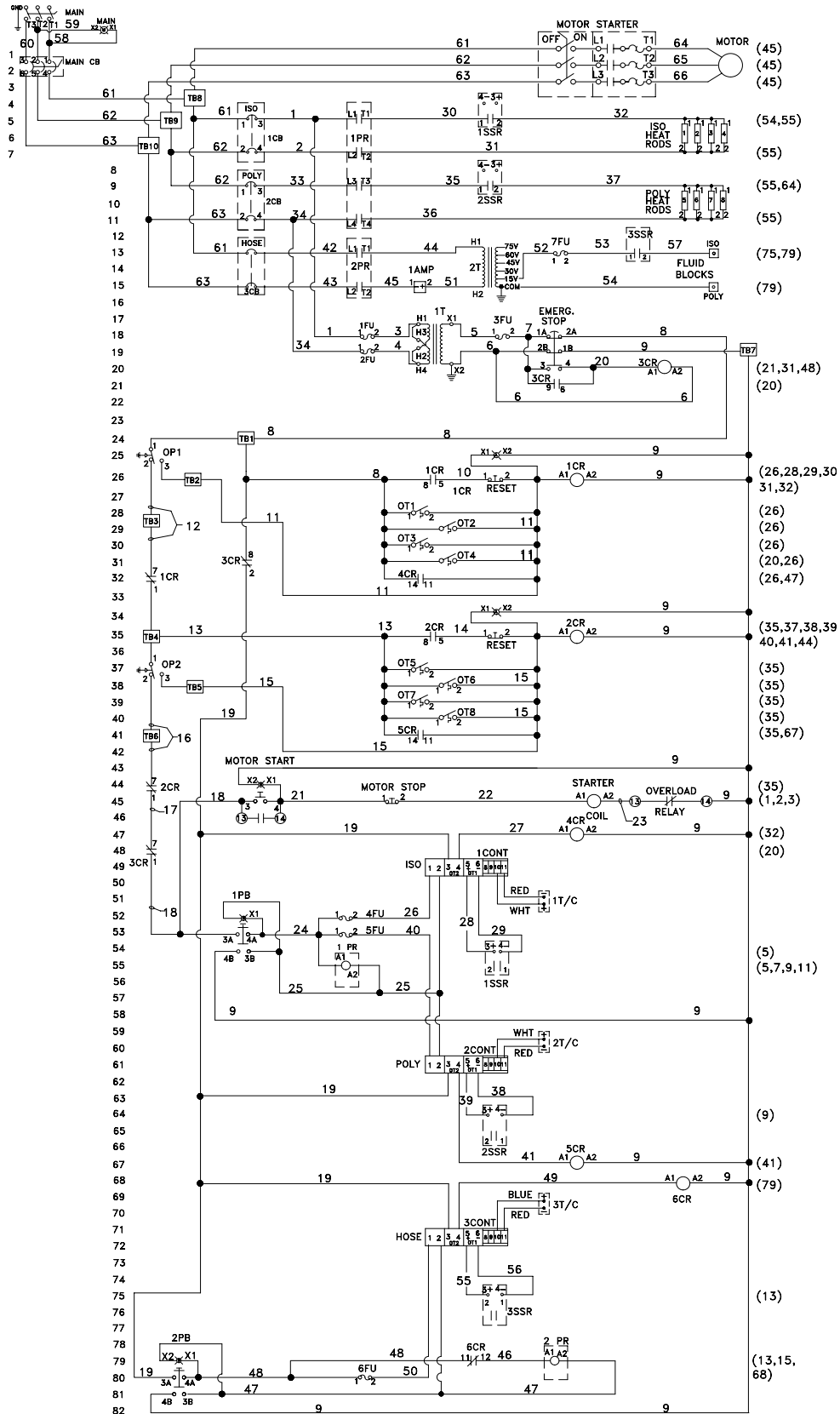

Section 3 - General Information: Sub Assembly Drawings

22140-03 System 380 Volt 3 Phase Schematic

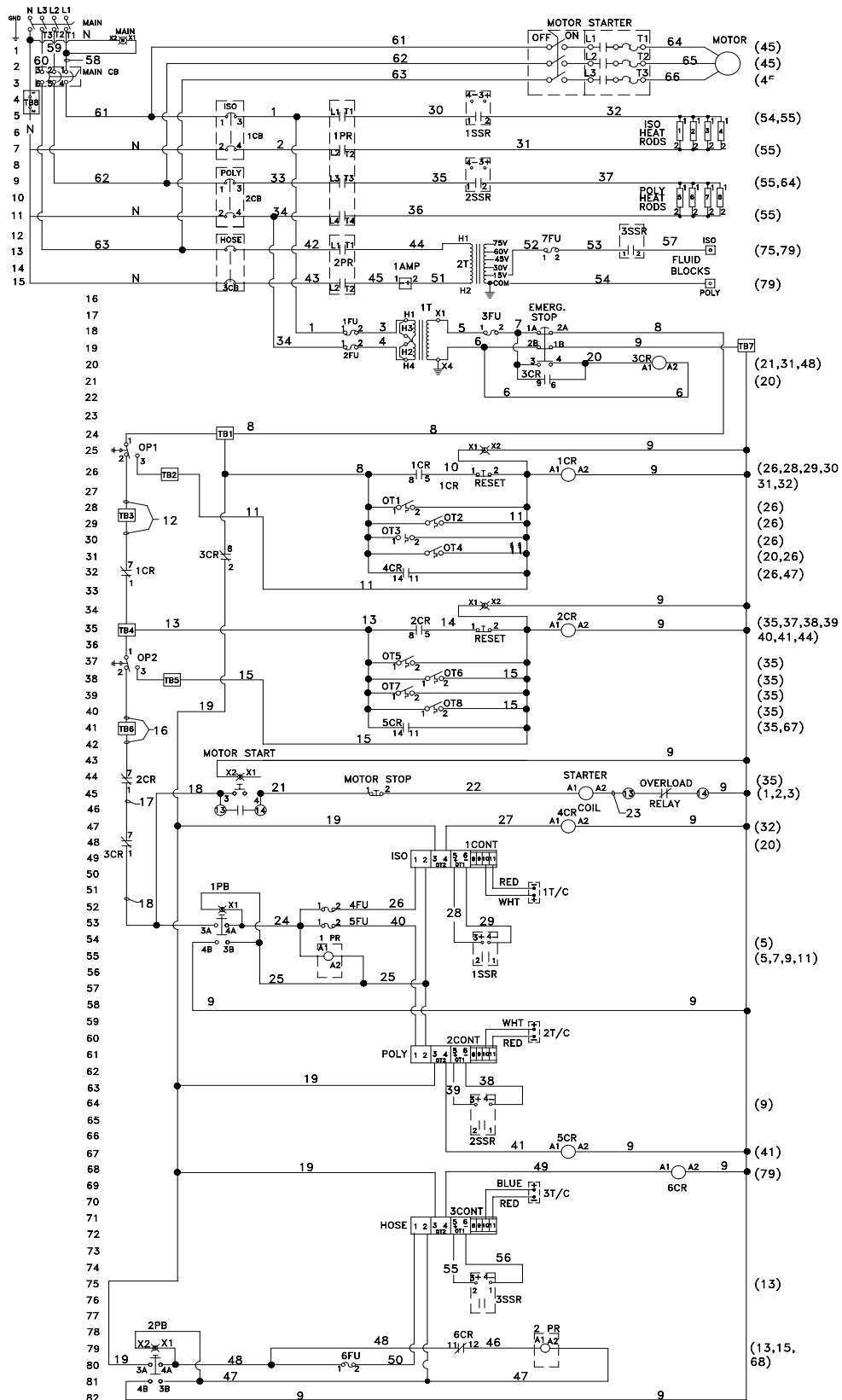

Section 3 - General Information: Sub Assembly Drawings

22350-00 Fluid Section Assembly

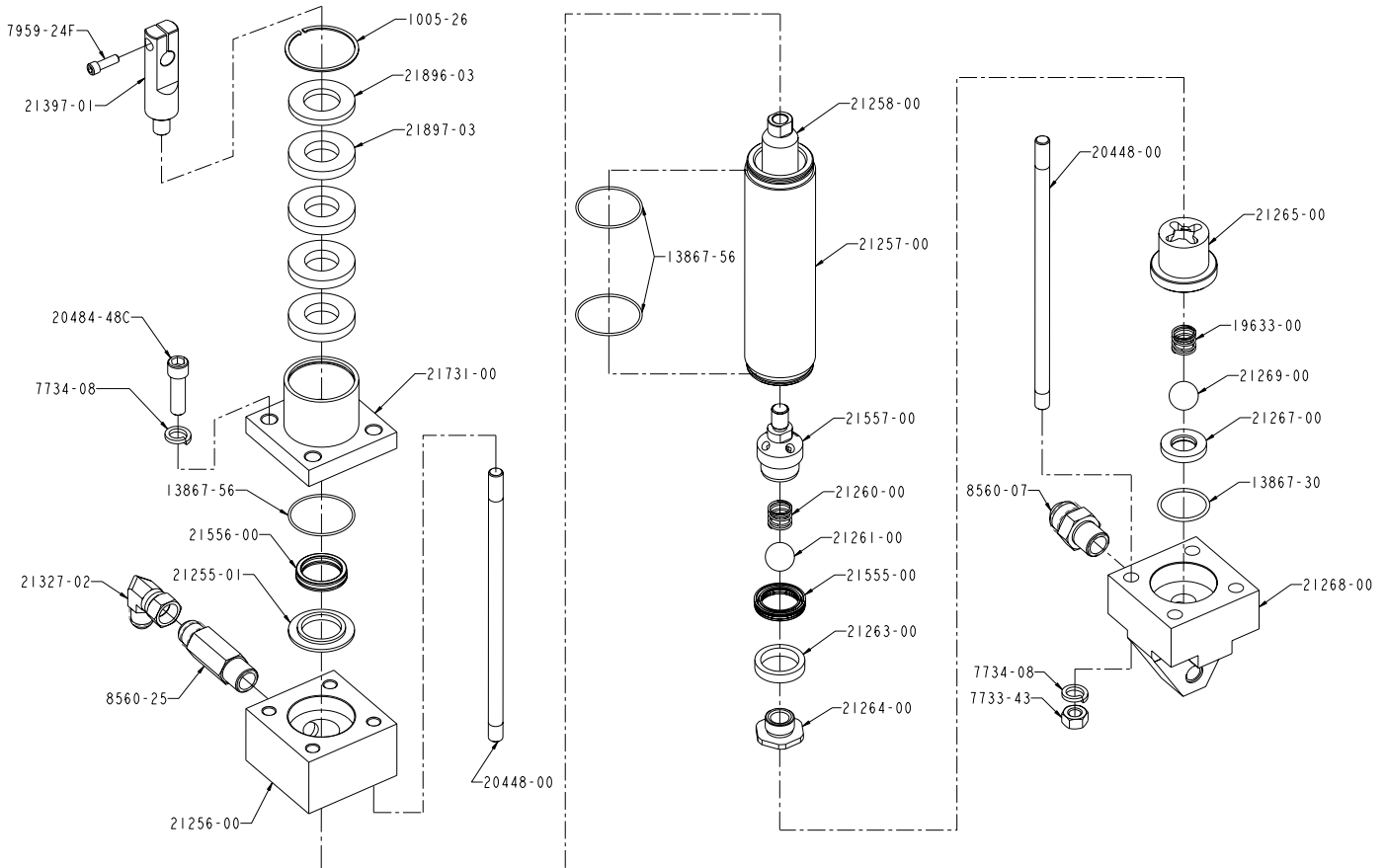

Part Number	Description	Qty.
1005-26	SNAP RING	1
13867-30	O-RING	1
13867-56	O-RING	3
19633-00	COMPRESSION SPRING	1
20448-00	PUMP TIE ROD	4
20484-48C	MACHINE SCREW	4
21255-01	SUPPORT WASHER	1
21256-00	PUMP HEAD	1
21257-00	PUMP CYLINDER	1
21258-00	PUMP SHAFT	1
21260-00	SPRING	1
21261-00	BALL	1
21263-00	PISTON GUIDE	1
21264-00	TRANSFER HOUSING SEAT	1
21265-00	FOOT VALVE BALL HOUSING	1
21267-00	FOOT VALVE SEAT	1

Part Number	Description	Qty.
21268-00	PUMP BASE	1
21269-00	FOOT VALVE BALL	1
21327-02	FTG,ELBOW,JIC,SW,3/4-16X7/8-14	1
21397-01	EXTENSION,SHAFT,INLINE	1
21555-00	SEAL,PUMP,URETHANE,LOWER 1.5:1	1
21556-00	SEAL,PUMP,URETHANE,UPPER 1.5:1	1
21557-00	HOUSING,TRANSFER,PUMP,1.5:1	1
21731-00	ADAPTER,CUP,SOLVENT,1.5:1	1
21896-03	RETAINER,PACKING,1.5:1	1
21897-03	FELT WIPER	4
7733-43	NUT,HEX,STD,7/16-14	4
7734-08	WASHER,LOCK,SPRING,7/16	8
7959-24F	SCREW,SHDC,SS,.250-28X .750	1
8560-07	FTG,CONNECTOR,37D,1/2NPTMX3/4T	1
8560-25	FTG,CONNECTOR,37D,1/2NPTMX5/8T	1

REPAIR KIT: 21277-00

REVISION C

Section 3 - General Information: Sub Assembly Drawings

22105-00 Heat Exchanger Assembly

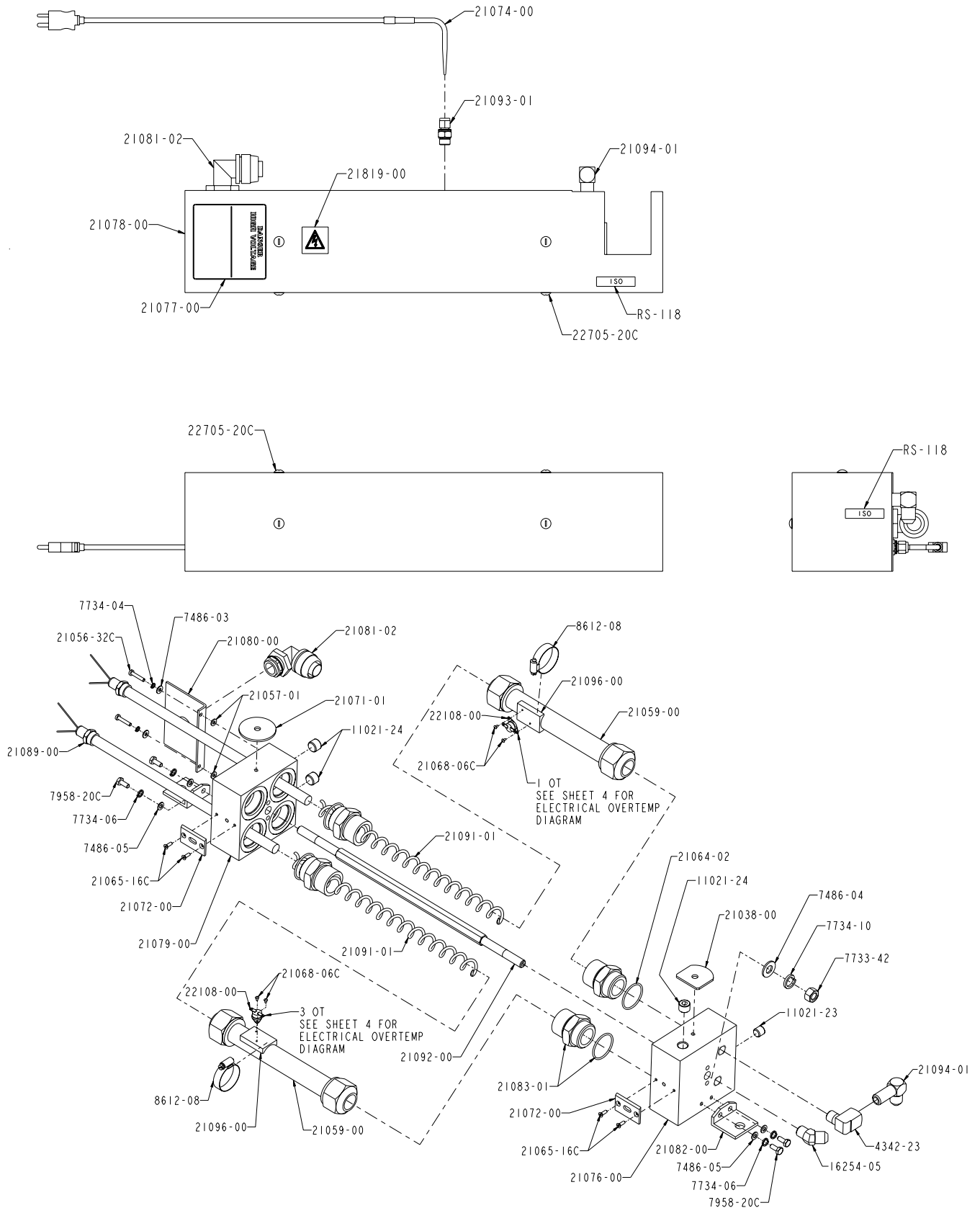

Section 3 - General Information: Sub Assembly Drawings

22105-00 Heat Exchanger Assembly

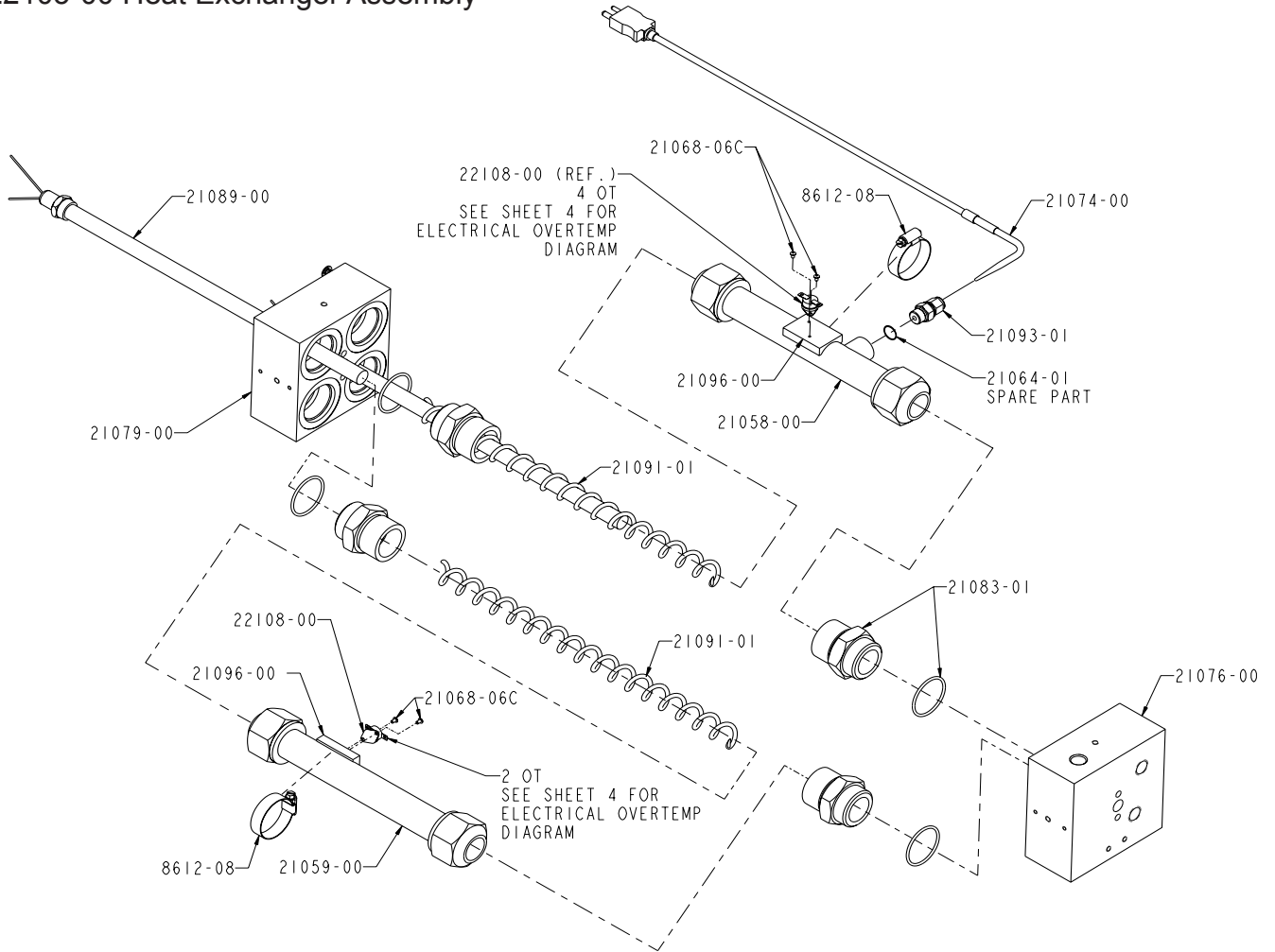

TOP TUBES

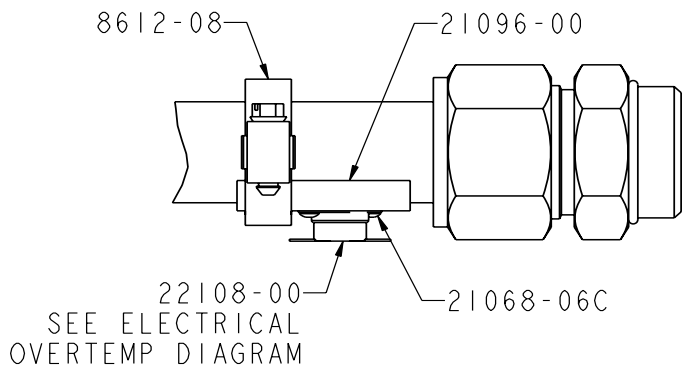

BOTTOM TUBES

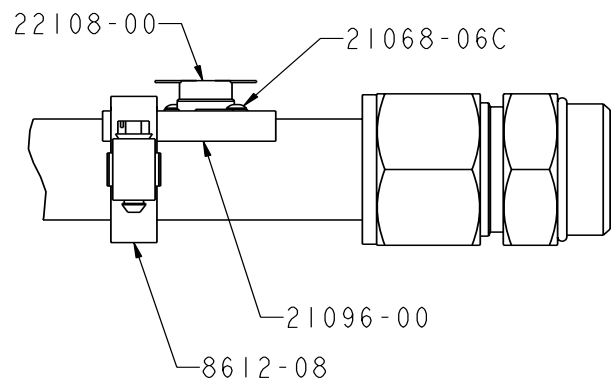

Section 3 - General Information: Sub Assembly Drawings

22105-00 Heat Exchanger Assembly

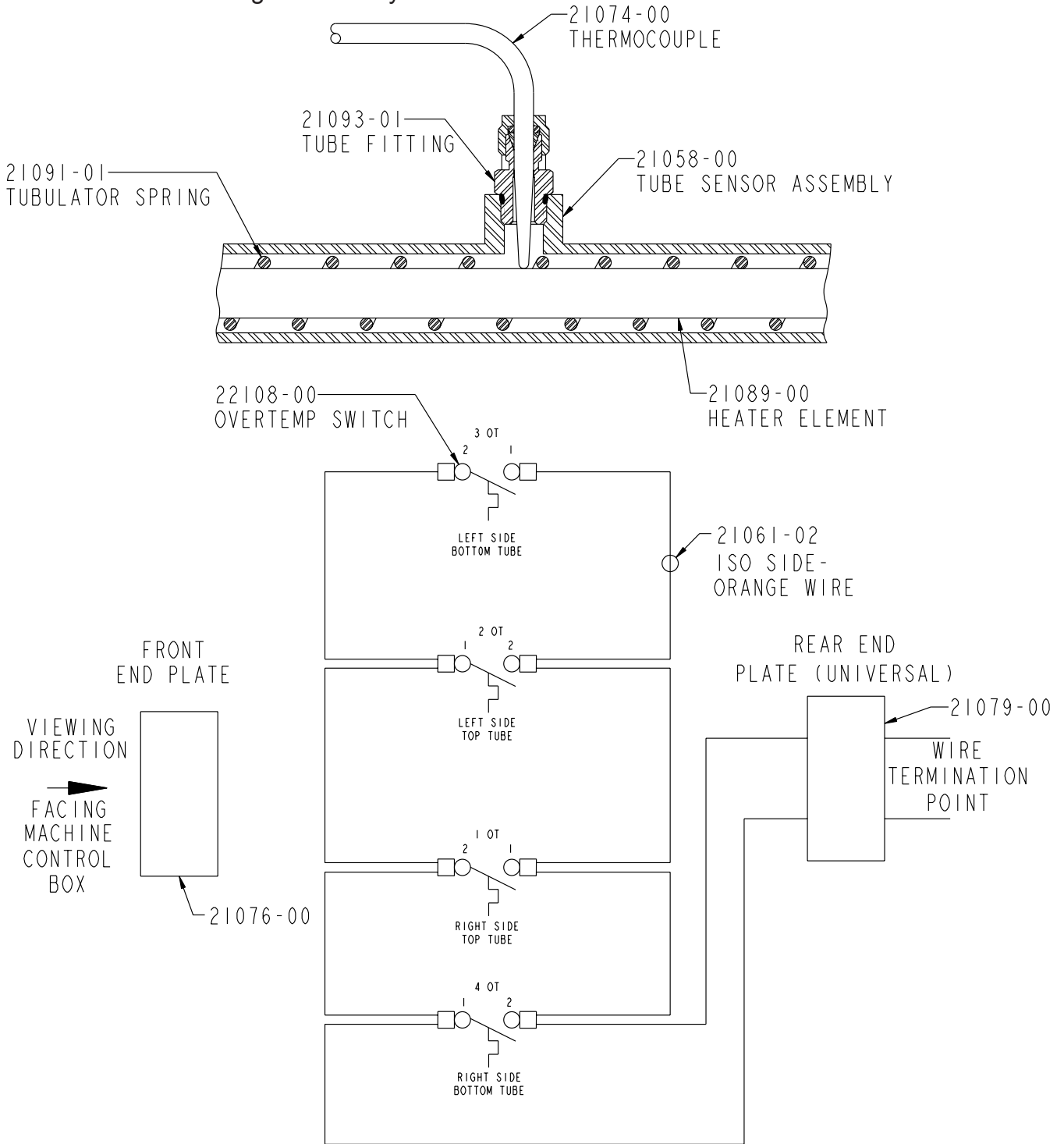

Note

When replacing thermocouple p/n: 21074-00, use kit p/n: 21214-01. Besure thermocouple is touching heater element before tightening.

Section 3 - General Information: Sub Assembly Drawings

22105-00 Heat Exchanger Assembly

Part Number	Description	Qty.
11021-23	PLUG	1
11021-24	PLUG	3
16254-05	FITTING	1
21038-00	FIBER WASHER	1
21056-32C	SCREW	2
21057-01	FIBER WASHER	2
21058-00	TUBE SENSOR ASSEMBLY	1
21059-00	HEATER TUBE ASSEMBLY	3
21064-01	O-RING	1
21064-02	O-RING	8
21065-16C	SCREW	4
21068-06C	SCREW	8
21071-01	FIBER WASHER	1
21072-00	INSULATOR PAD	2
21074-00	THERMOCOUPLE	1
21076-00	(ISO) FRONT END PLATE	1
21077-00	DANGER DECAL	1
21078-00	HEATER COVER	1
21079-00	(UNIVERSAL) REAR END PLATE	1
21080-00	MOUNTING BRACKET	1
21081-02	SWIVELLOK CONNECTOR	1
21082-00	MOUNTING BRACKET	2
21083-01	FITTING	8
21089-00	HEATER ELEMENT	4

Part Number	Description	Qty.
21091-01	TURBULATOR SPRING	4
21092-00	HEATER TIE ROD	1
21093-01	THERMOCOUPLE FITTING	1
21094-01	ELBOW FITTING	1
21096-00	THERMOSTAT MOUNTING PAD	4
21819-00	LIVE WIRE DECAL	1
22108-00	OVERTEMP SWITCH	4
22705-20C	SCREW	4
4342-23	ELBOW FITTING	1
7486-03	FLAT WASHER	2
7486-04	WASHER	2
7486-05	WASHER	4
7733-42	NUT	2
7734-04	LOCK WASHER	2
7734-06	LOCK WASHER	4
7734-10	LOCK WASHER	2
7958-20C	SCREW	4
8612-08	BAND CLAMP	4
RS-118	ISO DECAL	2

Section 3 - General Information: Sub Assembly Drawings

22110-00 Heat Exchanger Assembly

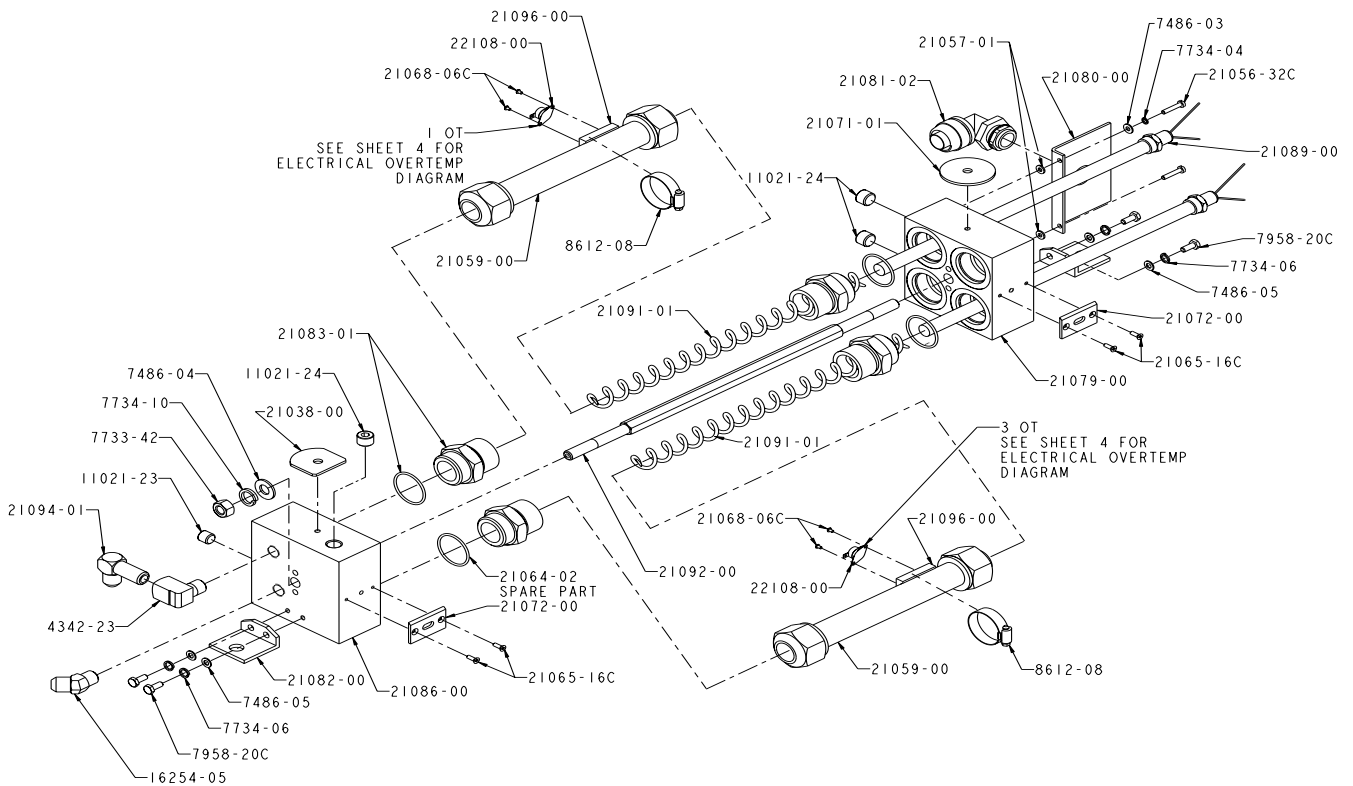
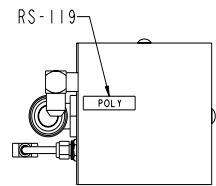
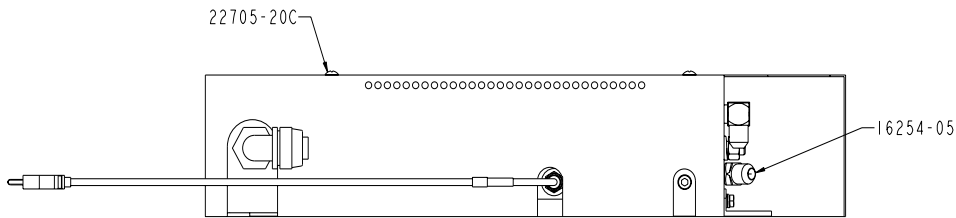
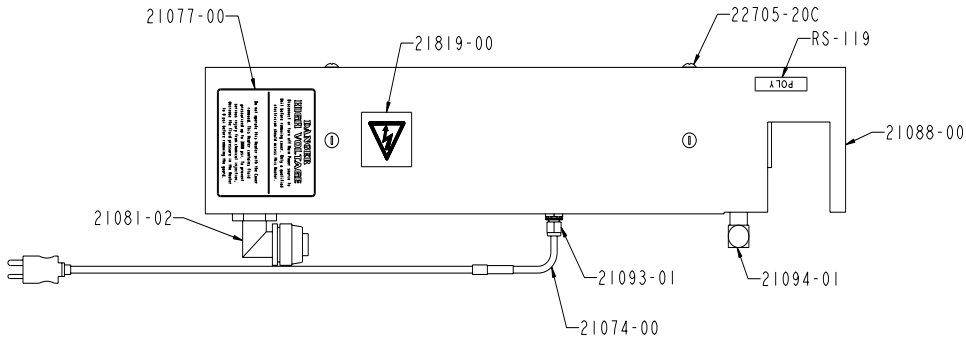

Section 3 - General Information: Sub Assembly Drawings

22110-00 Heat Exchanger Assembly

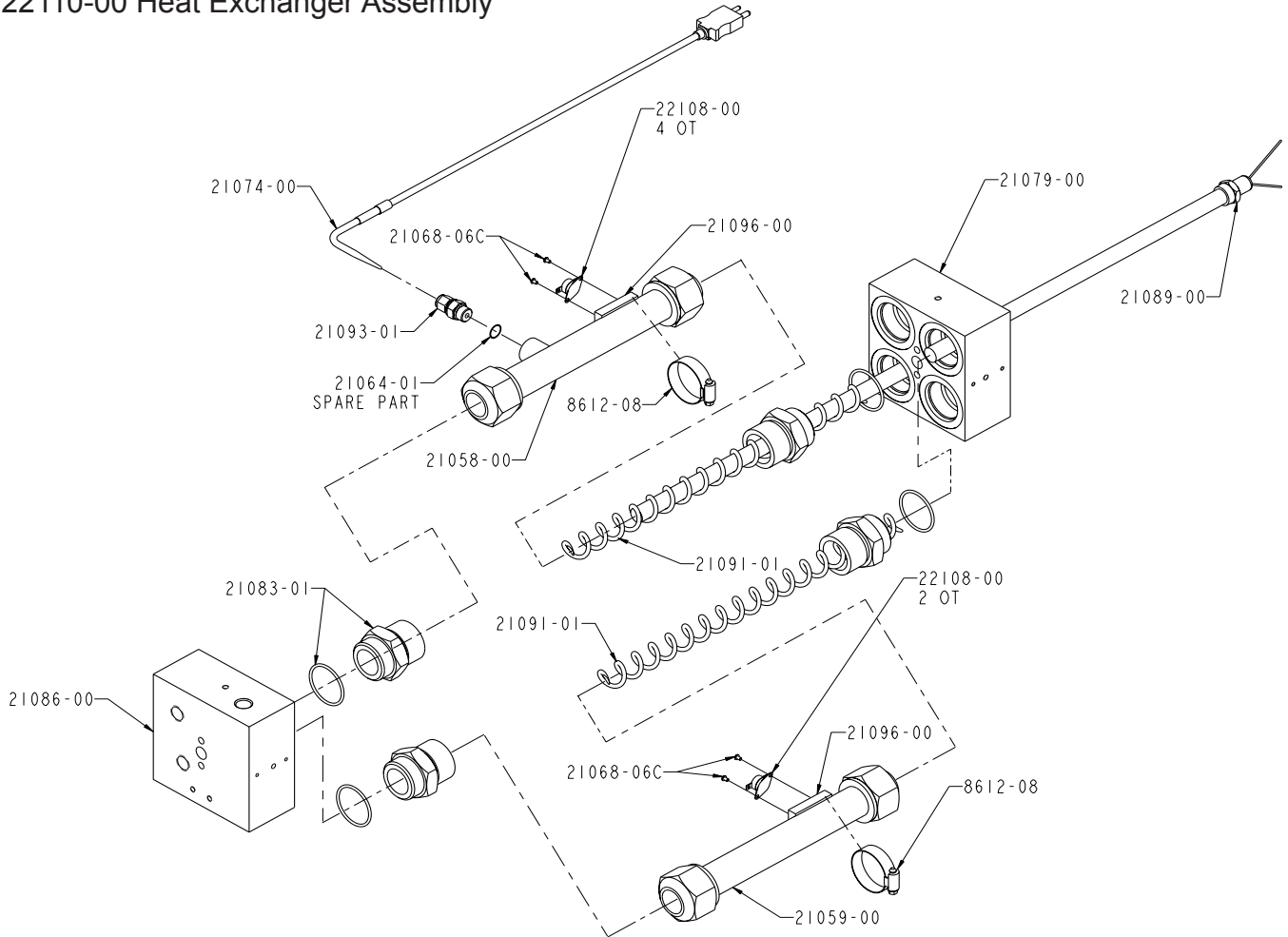

TOP TUBES

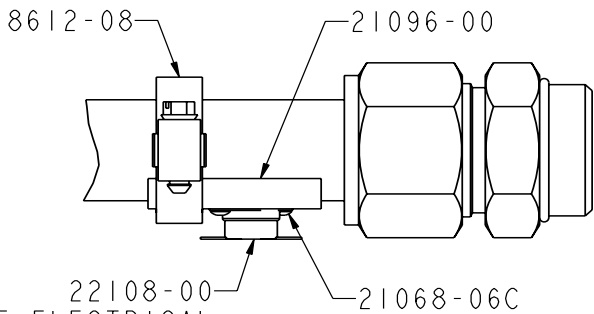

22108-00
SEE ELECTRICAL
OVERTEMP DIAGRAM

BOTTOM TUBES

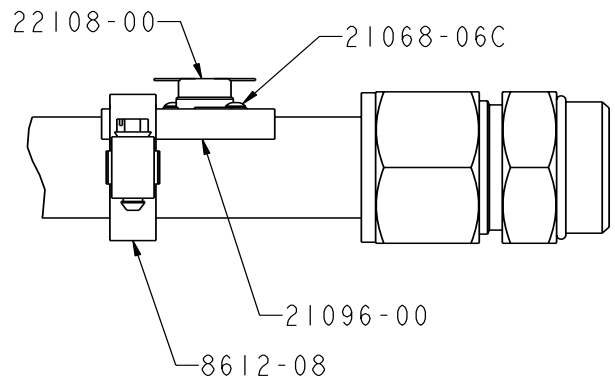

REVISION K

Section 3 - General Information: Sub Assembly Drawings

22110-00 Heat Exchanger Assembly

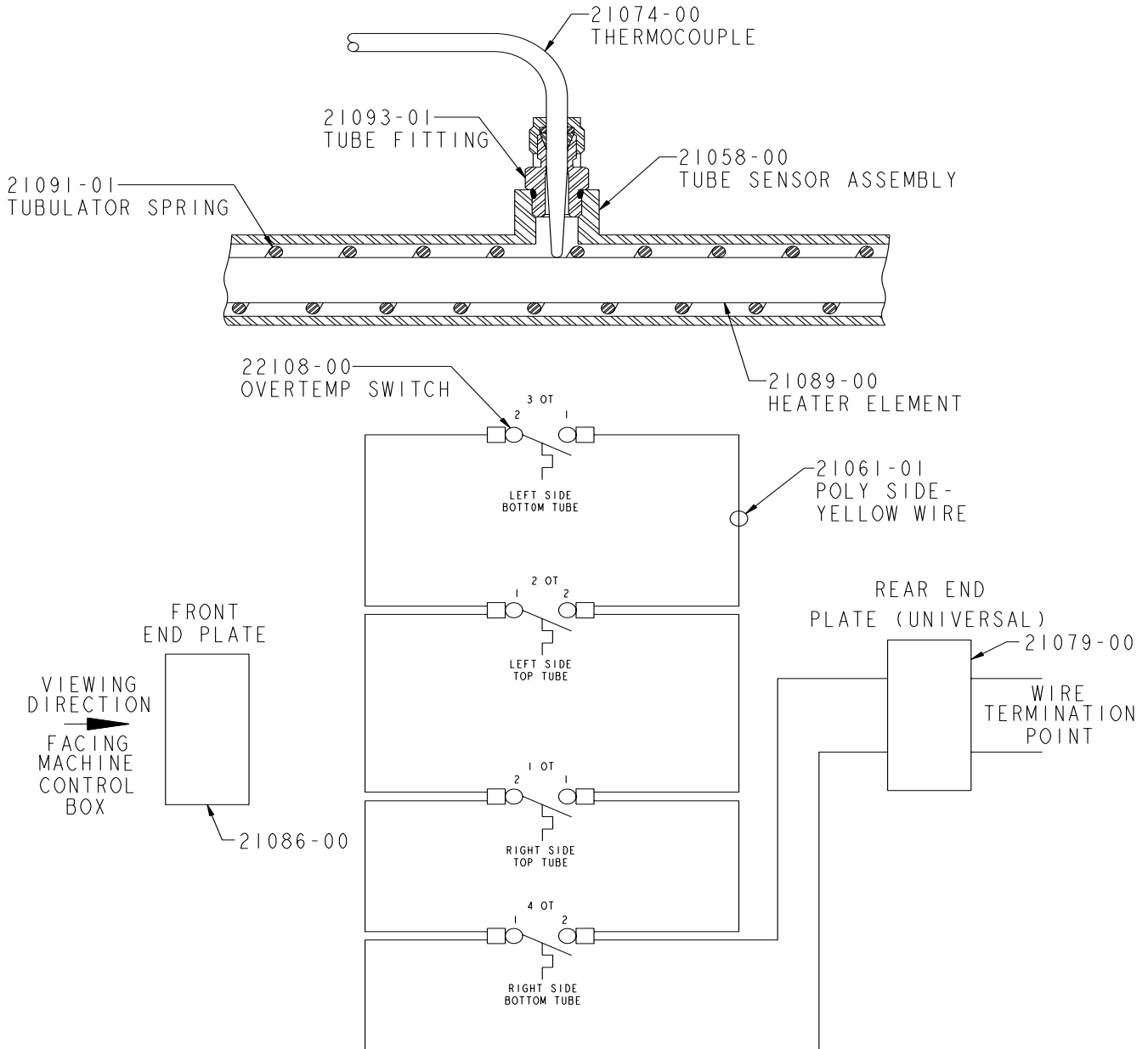

Note
 When replacing thermocouple p/n: 21074-00,
 use kit p/n: 21214-01. Besure thermocouple
 is touching heater element before tightening.

Section 3 - General Information: Sub Assembly Drawings

22110-00 Heat Exchanger Assembly

Part Number	Description	Qty.
11021-23	PLUG	1
11021-24	PLUG	3
16254-05	FITTING	1
21038-00	FIBER WASHER	1
21056-32C	SCREW	2
21057-01	FIBER WASHER	2
21058-00	TUBE SENSOR ASSEMBLY	1
21059-00	HEATER TUBE ASSEMBLY	3
21064-01	O-RING	1
21064-02	O-RING	8
21065-16C	SCREW	4
21068-06C	SCREW	8
21071-01	FIBER WASHER	1
21072-00	INSULATOR PAD	2
21074-00	THERMOCOUPLE	1
21077-00	DANGER DECAL	1
21079-00	(UNIVERSAL) REAR END PLATE	1
21080-00	MOUNTING BRACKET	1
21081-02	SWIVELLOK CONNECTOR	1
21082-00	MOUNTING BRACKET	2
21083-01	FITTING	8

Part Number	Description	Qty.
21086-00	(POLY) FRONT END PLATE	1
21088-00	(POLY) HEATER COVER	1
21089-00	HEATER ELEMENT	4
21091-01	TURBULATOR SPRING	4
21092-00	HEATER TIE ROD	1
21093-01	THERMOCOUPLE FITTING	1
21094-01	ELBOW FITTING	1
21096-00	THERMOSTAT PAD	4
21819-00	LIVER WIRE DECAL	1
22108-00	OVERTEMP SWITCH	4
22705-20C	SCREW	4
4342-23	ELBOW FITTING	1
7486-03	FLAT WASHER	2
7486-04	WASHER	2
7486-05	WASHER	4
7733-42	NUT	2
7734-04	LOCK WASHER	2
7734-06	LOCK WASHER	4
7734-10	LOCK WASHER	2
7958-20C	SCREW	4
8612-08	BAND CLAMP	4
RS-119	POLY DECAL	2

Section 3 - General Information: Sub Assembly Drawings

SPGN-RS- Probler P2 Spray Gun

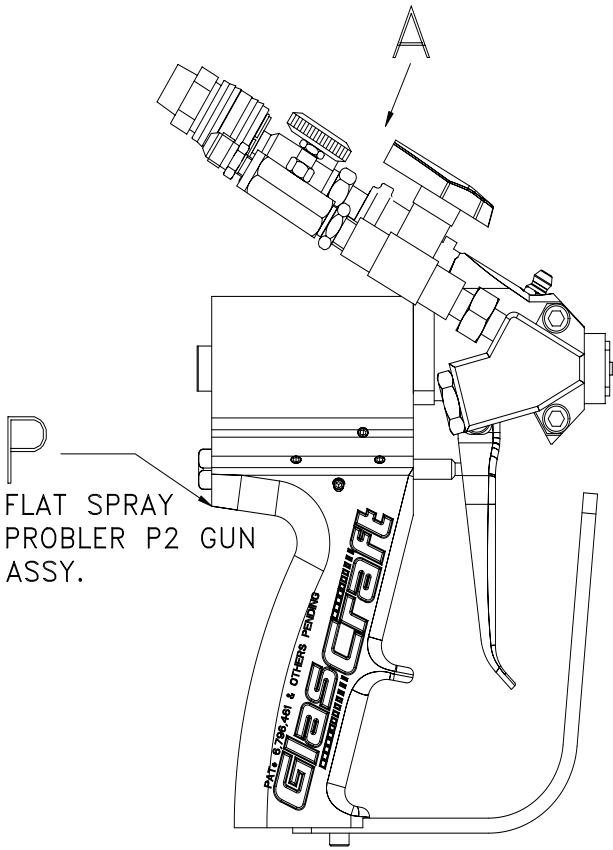

P
FLAT SPRAY
PROBLER P2 GUN
ASSY.

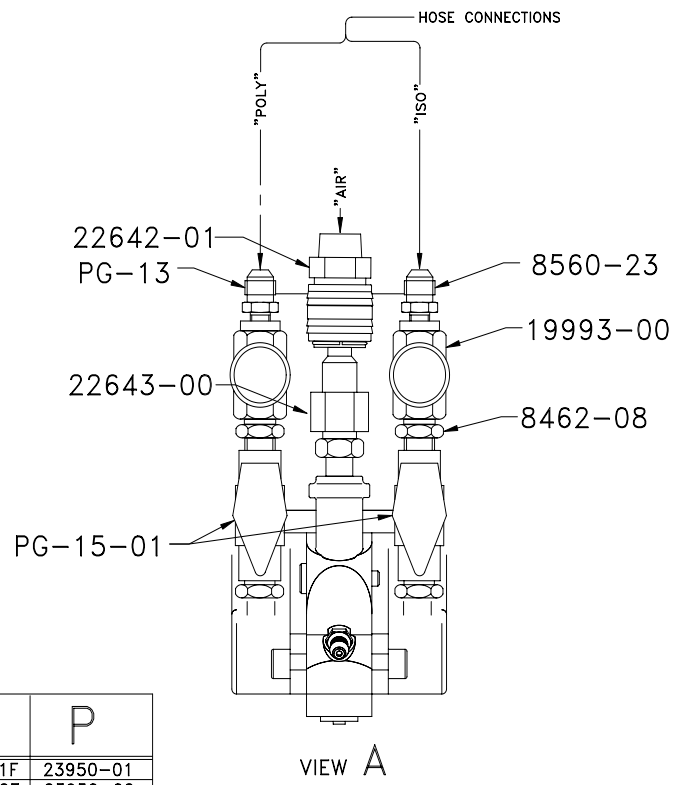

GLAS-CRAFT P/N	P
SPGN-RS-01F	23950-01
SPGN-RS-02F	23950-02

PART NUMBER	DESCRIPTION	QTY.
8462-05	FITTING	2
8560-23	JIC FITTING	1
19993-00	VALVE	2
22642-01	FEMALE QUICK DISCONNECT	1
22643-00	MALE QUICK DISCONNECT	1
PG-13	JIC FITTING	1
PG-15-01	VALVE	2

NOTE: Refer to Probler P2 gun user manual GC-1386.

Section 4 - Warranty and Reference Information: Technical Data

Material Ratio:	Variable
Material Viscosity:	200- 2000 Centipoise (Cps) At Operating Temperatures
Max Output (1 position):	.042 GPS .084 GPM
Operating Temperatures:	32° F (0° C) - 190° (88 ° C)
Operating Psi:	3200 Psi. Max (Over Psi Switches Set)
Purging:	Automatic Pneumatic, Solvent-free, Constant (Probler/Probler P2)
Electrical Requirements:	63 Amps @ 208/240 Vac, 50/60 Hz Three Phase 63 Amps @ 380 Vac, 50/60 Hz Three Phase
Compressed Air Requirements:	15 Cfm @ 100 Psi 425 Liters @ 6.8 Bar
Max Hose Length:	306' X 3/8 I.d. Hose Includes 6' X 1/4 I.d. Unheated Whip Hose
Overall Dimensions:	

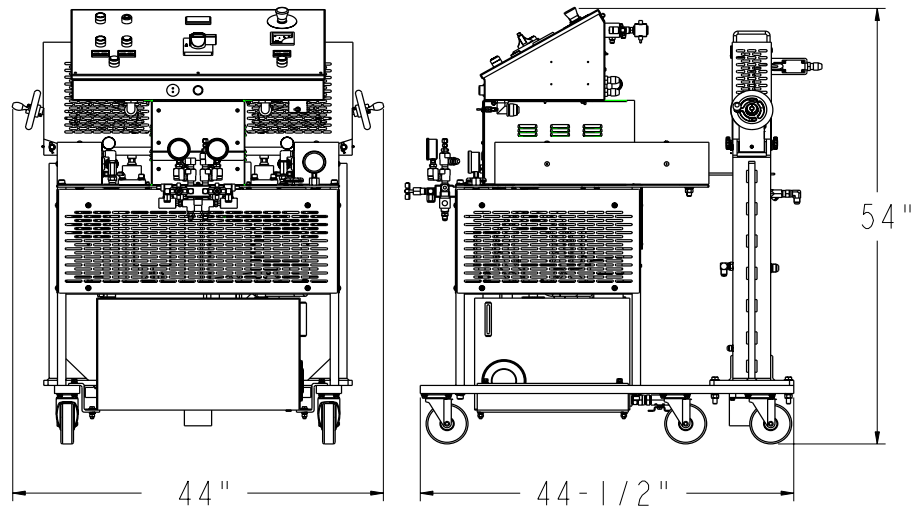

Shipping Weight: 1000 Lbs

Section 4 - Warranty and Reference Information: Limited Warranty Policy

GLASCRAFT, INC. ("GlasCraft") warrants to the original Purchaser of GlasCraft manufactured equipment and parts, that all GlasCraft manufactured equipment and parts will conform to their published written specifications and be free of defects in workmanship and material for a period of one (1) year from the original date of installation. GlasCraft makes no warranty to anyone other than the original Purchaser.

If any GlasCraft manufactured part or equipment is found to be defective in workmanship or material within the one-year period from the date of installation, as determined solely by GlasCraft, GlasCraft, in its sole discretion, will either repair or replace the defective part or equipment at GlasCraft's cost, including freight charges both ways, or credit or refund the purchase price for the defective equipment or part.

A warranty claim will be honored only when:

1. GlasCraft has been informed, in writing, of any such defect in workmanship or material within ten (10) days after discovery by the original Purchaser;
2. An official of GlasCraft has issued a return authorization number; and
3. The claimed defective equipment or part has been returned to GlasCraft by the original Purchaser, freight prepaid (with proper return authorization number(s) attached), to: GlasCraft, Inc., 5845 West 82nd Street, Suite 102, Indianapolis, IN 46278, U.S.A.

This warranty shall not apply to any equipment or parts that have been altered or repaired by anyone other than GlasCraft or to defects or damage resulting from improper installation, misuse, negligence, accident, or use not specified by GlasCraft. This warranty shall not apply to any equipment where any parts or components were replaced by any parts or components not manufactured or supplied by GlasCraft. The decision by GlasCraft shall be conclusive and binding on Purchaser.

GlasCraft does not warrant that any equipment or parts sold to Purchaser meet or comply with any local, state, federal, or other jurisdiction's regulations or codes. GlasCraft does not warrant that any equipment or part sold to Purchaser, when used individually or in concert with any other part, equipment, device, component or process, does not infringe on any patent rights of any third party. GlasCraft only warrants that it has no specific knowledge of any such infringement.

GlasCraft makes no warranty as to any parts or equipment manufactured by others. Purchaser shall look solely and only to the manufacturer of such parts or equipment with respect to any warranty claims. GlasCraft hereby assigns to Purchaser the original manufacturer's warranties to all such equipment and parts, to the full extent permitted.

THE AFORESAID WARRANTY IS IN LIEU OF ALL OTHER WARRANTIES, EXPRESS OR IMPLIED. SPECIFICALLY THERE ARE NO WARRANTIES OF MERCHANTABILITY OR FITNESS FOR A PARTICULAR PURPOSE, WHICH WARRANTIES ARE SPECIFICALLY DISCLAIMED.

GlasCraft shall not be liable for any loss or expense resulting from damage or accidents caused by improper use or application of materials manufactured or sold by GlasCraft or its distributors or agents.

UNDER NO CIRCUMSTANCES SHALL GLASCRAFT'S LIABILITY EXCEED THE AMOUNT PURCHASER PAID FOR THE CLAIMED DEFECTIVE EQUIPMENT OR PART. UNDER NO CIRCUMSTANCES SHALL GLASCRAFT BE LIABLE FOR INCIDENTAL OR CONSEQUENTIAL DAMAGES OR FOR LOST PROFITS.

No action arising from or relating to any goods manufactured by or purchased from GlasCraft may be brought more than one (1) year after the cause of action accrues.

Section 4 - Warranty and Reference Information: Technical Assistance.....

Thank You for selecting GlasCraft spray equipment

Should you have any questions or need technical assistance, contact your factory authorized GlasCraft distributor.

Distributor: _____

Phone: _____

Contact: _____

For any issues your distributor cannot address, the GlasCraft technical service department is always available to assist you with the operation of your spray equipment. To help our technical representatives expedite your call and better address your questions, please have the following information ready and available when you phone GlasCraft.

*** If your questions are not urgent, You can e-mail all correspondence to service@glascraft.com**

Model: _____

Serial number: _____

Type of spray gun: _____

Serial number: _____

Is your equipment:

Single phase: _____ Three phase _____

What is the inbound voltage
to your equipment: _____

Temperature setting ISO: _____

Temperature setting POLY: _____

Temperature setting HOSE: _____

For Air Powered Systems:

Air compressor size: _____

CFM generated: _____

Pressure at the system:

Hydraulic _____ Pneumatic _____

Dynamic fluid pressure:

ISO _____ POLY _____

Spray gun chamber size: _____

Material being sprayed: _____

Viscosity: ISO _____ POLY _____

Approximate material temperature: _____

For Your Reference



Date Purchased _____
Distributor _____

Contact _____
Phone _____
E-mail _____

GlasCraft manufactures a complete line of polyurethane foam and polyurea coating spray systems. If your application is in-plant or a field contractor - GlasCraft has a system package to meet your requirements.

GUARDIAN - AIR POWERED / A5 & A6 SERIES EQUIPMENT

- . 6000 OR 12000 WATTS OF HEAT
- . 1600, 2200, OR 3000 PRESSURE SET-UPS AVAILABLE

MH, MH II, & MH III HYDRAULIC POWERED SYSTEMS

- . UP TO 45 LBS / MINUTE OUTPUT
- . EXCELLENT PERFORMANCE AND RELIABILITY

GUARDIAN MMH - MOBILE MODULAR HYDRAULIC SYSTEMS

- . SPECIFICALLY DESIGNED FOR ANY TYPE OF SPRAY RIG
- . GIVE COMPLETE UTILIZATION OF FLOOR SPACE IN MOBILE RIG

PROBLER P2 SPRAY GUN

- . IMPINGEMENT MIX / AIR PURGE
- . OPTIONAL NOZZLE FOR SPRAYING STUD WALLS, POURING & STREAM JET

For more information concerning any of these GlasCraft products,
contact your local authorized GlasCraft distributor or visit www.glascraft.com

Quality and Performance...

GENUINE GLASCRAFT

Glas **Craft**

DISPENSING EXCELLENCE



www.glascraft.com

GC-1300

REVISION L

A GRACO COMPANY

GRACO INC.

P.O. BOX 1441

MINNEAPOLIS, MN 55440-1441

Phone 612-623-6921

Toll Free 1-800-328-0211

Fax 612-378-3505