

# USER MANUAL

# GUARDIAN

*MMH 206/212*

*Mobile Modular Hydraulic Dispensing System*



# Table Of Contents

## Section 1 Installation

1:1 Introduction ..... 1  
1:2 Standard Equipment ..... 2  
1:3 Specifications ..... 3  
1:4 Equipment Assembly ..... 4

## Section 2 Operation

2:1 Start-up Instructions ..... 15  
2:2 Shut-down Instructions ..... 24  
2:3 Daily Start-Up Instructions ..... N/A

## Section 3 General Information

3:1 Assembly Drawings ..... N/A  
3:2 Sub Assembly Drawings ..... 26  
3:3 Maintenance ..... 44  
3:4 Troubleshooting ..... 45  
3:5 Options ..... 46

## Section 4 Safety Information

4:1 General Safety ..... 52  
4:2 Notes ..... 56  
4:3 Limited Warranty Policy ..... 57  
4:4 Technical Assistance ..... 58  
For Your Reference ..... **INSIDE BACK COVER**

N/A = Non Applicable

## Section 1 - Installation: Introduction

Before operating, maintaining or servicing any **GlasCraft** system, read and understand all of the technical and safety literature provided with **GlasCraft** products. If you do not have the proper or related manuals and safety literature for your **GlasCraft** system, contact your **GlasCraft** distributor or **GlasCraft, Inc.**

In this **GlasCraft** technical and safety publication, the following advisories will be provided where appropriate:



Is information about the procedure in progress.



*Is imperative information about equipment protection.*



*Indicates a hazardous situation which, if not avoided, could result in minor or moderate injury.*



*Indicates a hazardous situation which, if not avoided, could result in death or serious injury.*

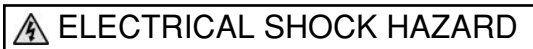

*Indicates a hazardous situation which, if not avoided, could result in electrical shock or serious injury.*

The information in this document is intended only to indicate the components and their normal working relationship typical use. Each assembly should be directed by a **GlasCraft** distributor or made from the **GlasCraft** Assembly instructions provided.

This manual provides information for the assembly, operation, maintenance and service of this **GlasCraft** product as used in a typical configuration. While it lists standard specifications and procedures, some deviations may be found.

In order to provide our users with the most up-to-date technology possible, we are constantly seeking to improve products. If technological change occurs after a product is on the market, we will implement that technology in future production and, if practical, make it available to current users as a retrofit, up-date or supplement. If you find some discrepancy between your unit and the available documentation, contact your **GlasCraft** distributor to resolve the difference. **GlasCraft, Inc.** reserves the right to change or modify this product as it deems necessary.

Careful study and continued use of this manual will provide a better understanding of the equipment and process, resulting in more efficient operation, longer trouble-free service and faster, easier troubleshooting.

## Section 1 - Installation: Standard Equipment

**Model - GUARDIAN MMH 206 / 212**

<b>Standard Equipment 206</b>	
<b>Part Number</b>	<b>Description</b>
19524-01	MANUAL HOSE 50 FT.
22290-01	PORTABLE TRANSFORMER
22808-00	HOSE MOUNTING KIT
22809-00	MATERIAL TRANSFER KIT
22810-00	ELECTRICAL WIRE WAY KIT
22878-00	HOSE SUPPORT KIT
22879-00	CONTROL CABLE KIT
23436-04	RECIRCULATION KIT
GC-1397	USER MANUAL
SM-1424	PARTS LIST
SM-1425	PARTS LIST

<b>Standard Equipment 212</b>	
<b>Part Number</b>	<b>Description</b>
22895-02	CONTROL BOX
22870-02	MATERIAL PUMP
22885-02	HEATER BOX ASSEMBLY
22808-00	HOSE MOUNTING KIT
22809-00	MATERIAL TRANSFER KIT
22810-00	ELECTRICAL WIRE WAY KIT
22878-00	HOSE SUPPORT KIT
22879-00	CONTROL CABLE KIT
19524-01	MANUAL HOSE 50 FT.
GC-1397	USER MANUAL
SM-1424	PARTS LIST
SM-1425	PARTS LIST

## Section 1 - Installation: Specifications

### MMH 206



Material Ratio:	1:1 (Fixed)
Material Viscosity:	200- 2000 Centipoise (Cps) At Operating Temperatures
Output:	Gallons Per Cycle = .042 Liters Per Cycle = .159
Operating Temperatures:	32° F ( 0° C ) - 190° (88 ° C )
Operating Psi:	2200 Psi. Max (Over Psi Switches Set)
Hydraulic Psi To Pumps:	2:1 Ratio 1000 PSI. Hydraulic PSI. 2000 PSI. Fluid PSI. Per Side.
Purging:	Automatic Pneumatic, Solvent-free, Constant (Probler / Probler P2)
Electrical Requirements:	68 Amps @ 208/240 Vac, 50/60 Hz Single Phase 5 HP 28 Amps @ 208/240 Vac, 50/60 Hz Three Phase 5 HP
Compressed Air Requirements:	15 Cfm @ 100 Psi / 425 Liters @ 6.8 Bar
Max Hose Length:	310 ft.X3/8 in. I.d. Hose Includes 10 ft.X¼ in. I.d. Heated Whip Hose

### MMH 212

Material Ratio:	1:1 (Fixed)
Material Viscosity:	200- 2000 Centipoise (Cps) At Operating Temperatures
Output:	Gallons Per Cycle = .042 Liters Per Cycle = .159
Operating Temperatures:	32° F ( 0° C ) - 190° (88 ° C )
Operating Psi:	3000 Psi. Max (Over Psi Switches Set)
Hydraulic Psi To Pumps:	2:1 Ratio 1000 PSI. Hydraulic PSI. 2000 PSI. Fluid PSI. Per Side.
Purging:	Automatic Pneumatic, Solvent-free, Constant (Probler / Probler P2)
Electrical Requirements:	28 Amps @ 208/240 Vac, 50/60 Hz Three Phase
Compressed Air Requirements:	15 Cfm @ 100 Psi / 425 Liters @ 6.8 Bar
Max Hose Length:	310 ft.X3/8 in. I.d. Hose Includes 10 ft.X¼ in. I.d. Heated Whip Hose

## Section 1 - Installation: Equipment Assembly

1. Before attaching any components or modules, read and study the following instructions and layout diagrams carefully. remember **tongue weight** and **balance** are very important when planing your trailer layout and placing heavy components such as the air compressor and generator.
2. GlasCraft recommends that the control box, heater box, and fluid section are attached to the trailer wall as shown to allow the supplied cables and hose to reach with no interferences.

-  MOST trailer wall frames are 16in. on center. contact your trailer manufacturer for any questions.
-  If the heater box and control box CANNOT be attached as shown be sure they are no more than 8ft. apart .
-  The fluid section should be securely attached to the trailer floor or wheel well BEFORE attaching the upper bracket to the trailer wall.

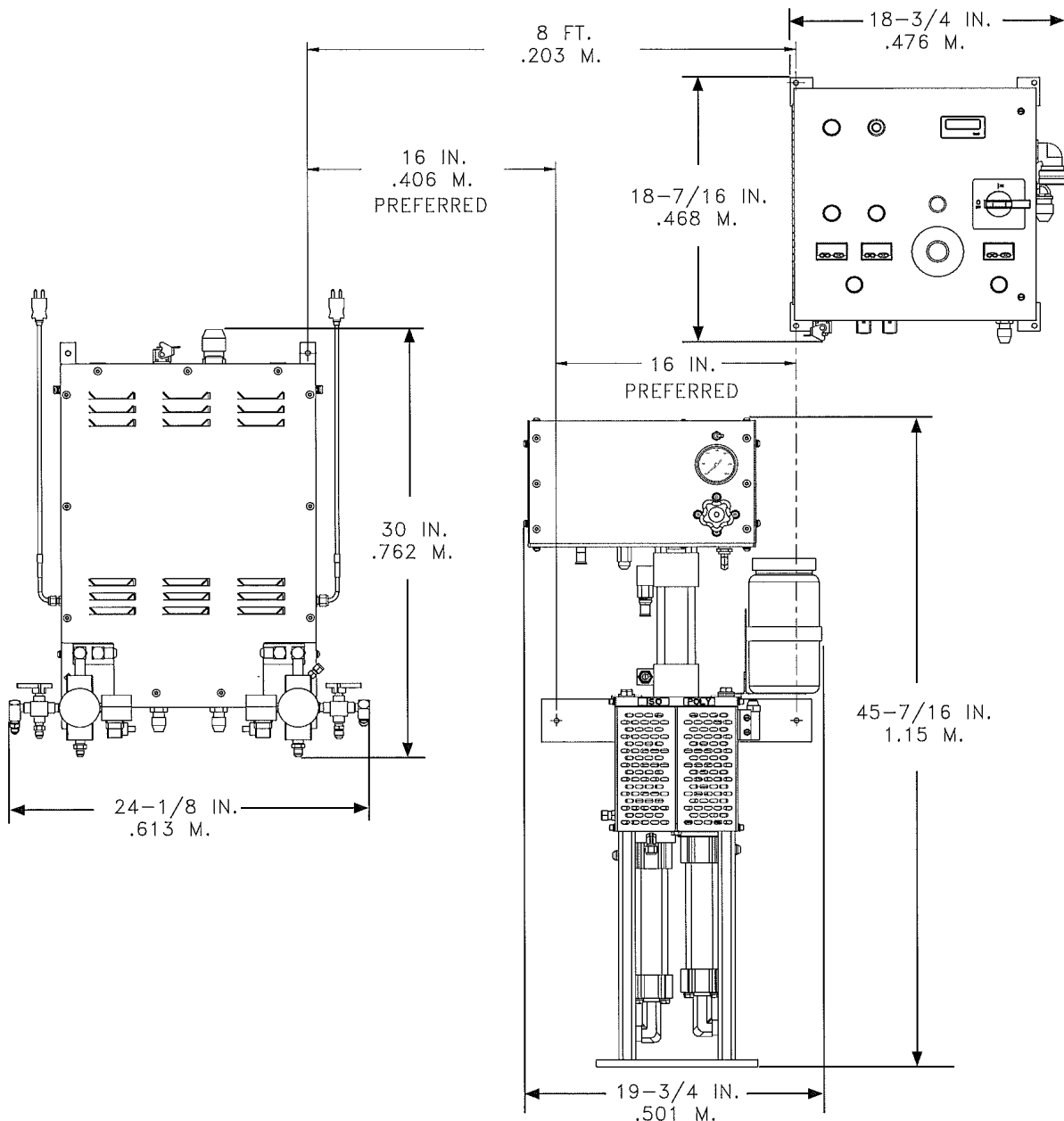

# Section 1 - Installation: Equipment Assembly

## Hoses & Hose Clamps

Most hoses will require multiple hose clamps unless noted. Also note that recommended quantities and mounting locations will vary based on the layout of components. *It is strongly recommended that all hoses are marked according to there mating component.*

- I.E. ISO hoses = Wrap with "red" tape
- POLY hoses = Wrap with "blue" tape.

Also mark thermocouple extension cords (22826-00).

A = "red"

B = "blue"

Thermocouple hose = unmarked

3. Attach the rails p/n 22837-00 to the trailer wall with self-taping screws p/n 21953-32.

 When attaching the hose clamp rails, conduit clamps, or cables it is **recommended** that they be attached to trailers structure.

*I.E. Wall or ceiling studs, heavy gauge steel or aluminum, or plywood 3/8in. or greater.*

- **Hydraulic Control Hose** p/n 18007-25 Attach with hose clamps p/n 22835-01 (Qty. 6).
- **Hydraulic PSI feed and Return to Tank Hoses** p/n 22898-00 Attach with hose clamps p/n 22836-01 (Qty. 6).
- **Pump to Heater Transfer Hoses** p/n's 22938-05 (A-side) & 22938-06 (B-side) Attach with hose clamps p/n 22836-01 (Qty. 1).
- **Transfer feed Hoses (Transfer Pump to Main Pump Inlet)** p/n 22897-00 Attach with hose clamps p/n 22836-02 (Qty. 4).
- **Recirculation Hoses (From 3-way common out to drum)** p/n's 18007-25 (A-side) & 18008-25 (B-side) Attach with hose clamps p/n 22836-02 (Qty. 4).

 Refer to the point to point diagrams.

Part Number	Hose marking Number	Size	Min Bend Radius	Max Operating PSI
7478-00	3420-04	1/4 in. i.d.	1 in.	3300
21341-00	3800-08	1/2 in. i.d.	4 in.	3500
T4-155-04	3130-12	3/4 in. i.d.	5 in.	1250

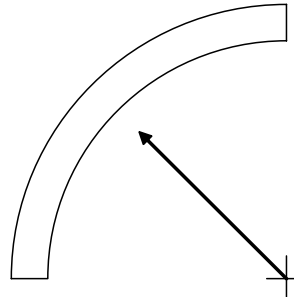

Minimum Bend Radius for Glas Craft Hoses

## Wires & Cables

4. Route and attach the hose control wires from the portable transformer (22290-01) to the control panel (22895-00), using the convoluted sleeving (22813-00) with straps (22814-03) and hardware (22706-24). Refer to the point to point diagram.

 When routing the control cables for the hydraulic power pack and the transformer (22824-00). mark the cables so that you can identify them easily.

After routing and attaching power cords, it maybe necessary to strip wires and attach crimp-on connectors.

- Strip back the rubber cover from the wire bundle and route the individual wires through the console and wire-way.
- Cut the wires to required length.
- Strip the insulation off of each wire, approx. 3/8in..
- Crimp the required lugs on each wire using crimps capable of achieving a 1/4in. wide depression. The wire should not be loose in the crimp. Check by twisting and pulling on both the wire and terminal.

# Section 1 - Installation: Equipment Assembly

Sec. 1:4

Control Panel

Main power cable  
to breaker box

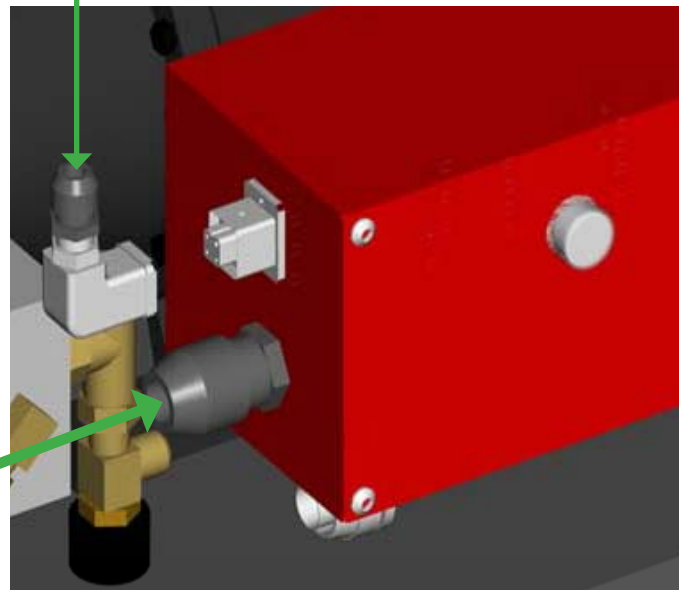
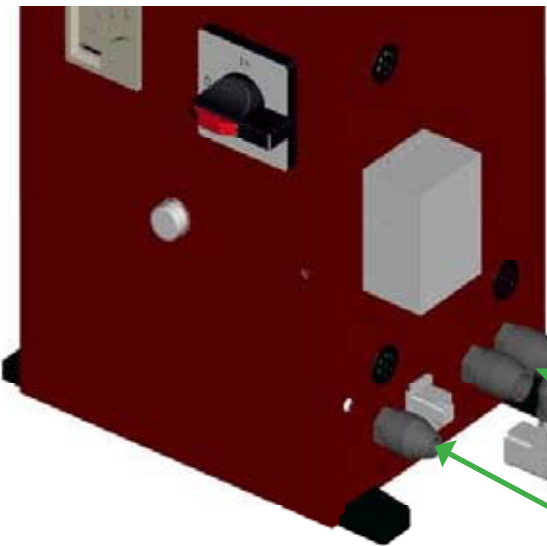
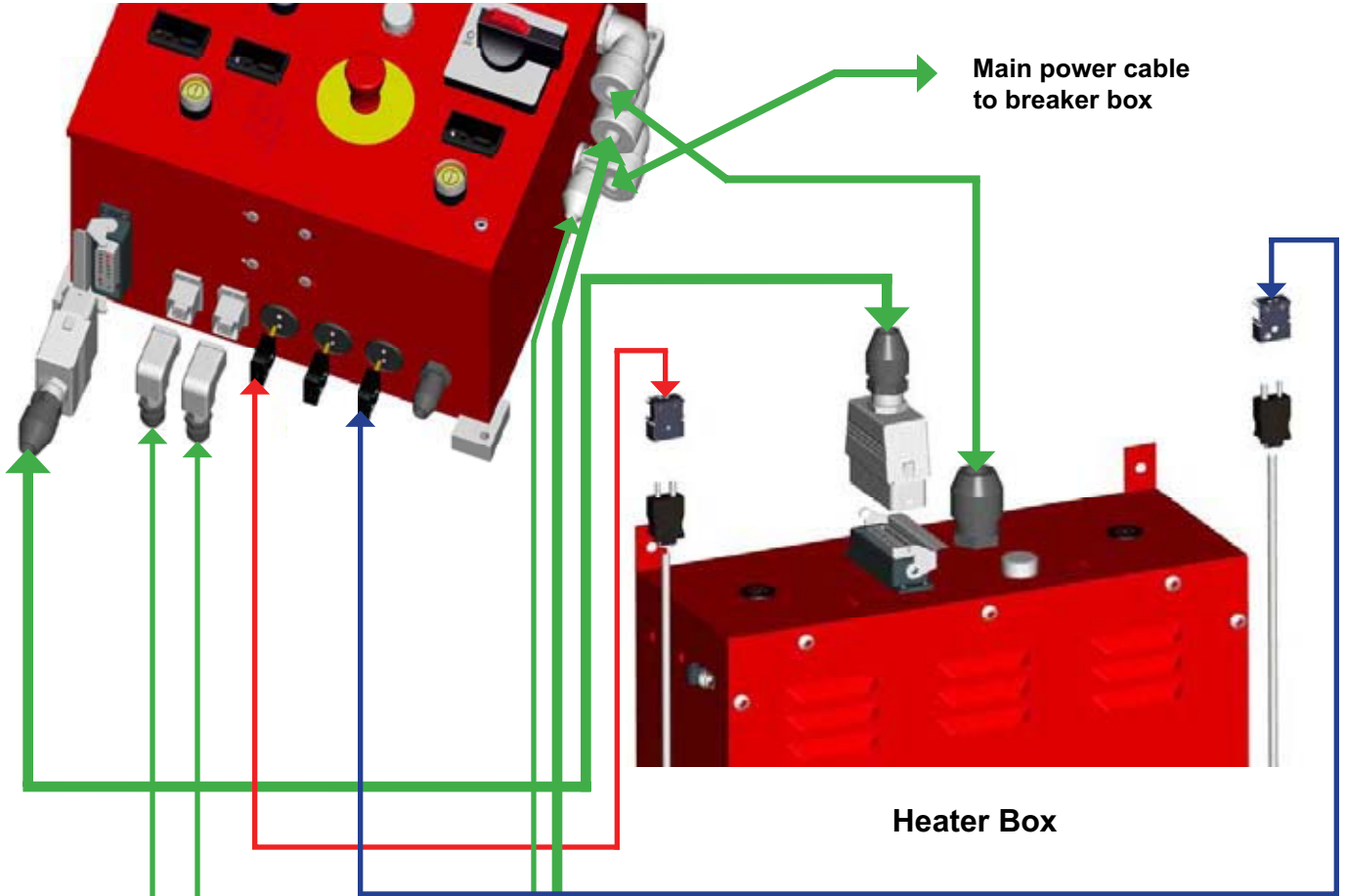

Hydraulic Power Pack



# Section 1 - Installation: Equipment Assembly

Sec. 1:4

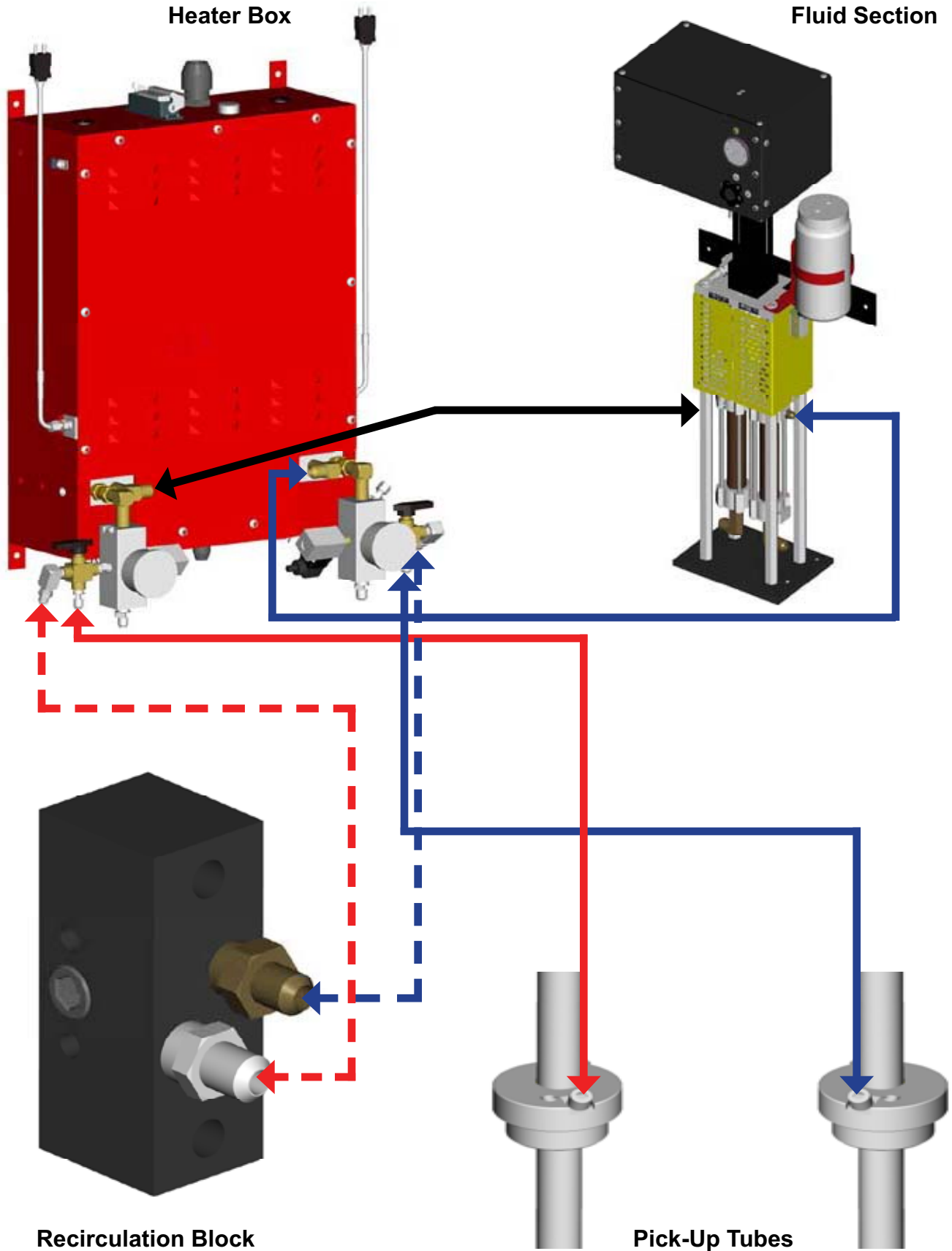

# Section 1 - Installation: Equipment Assembly

Sec. 1:4

## Diaphragm Transfer Pump Option

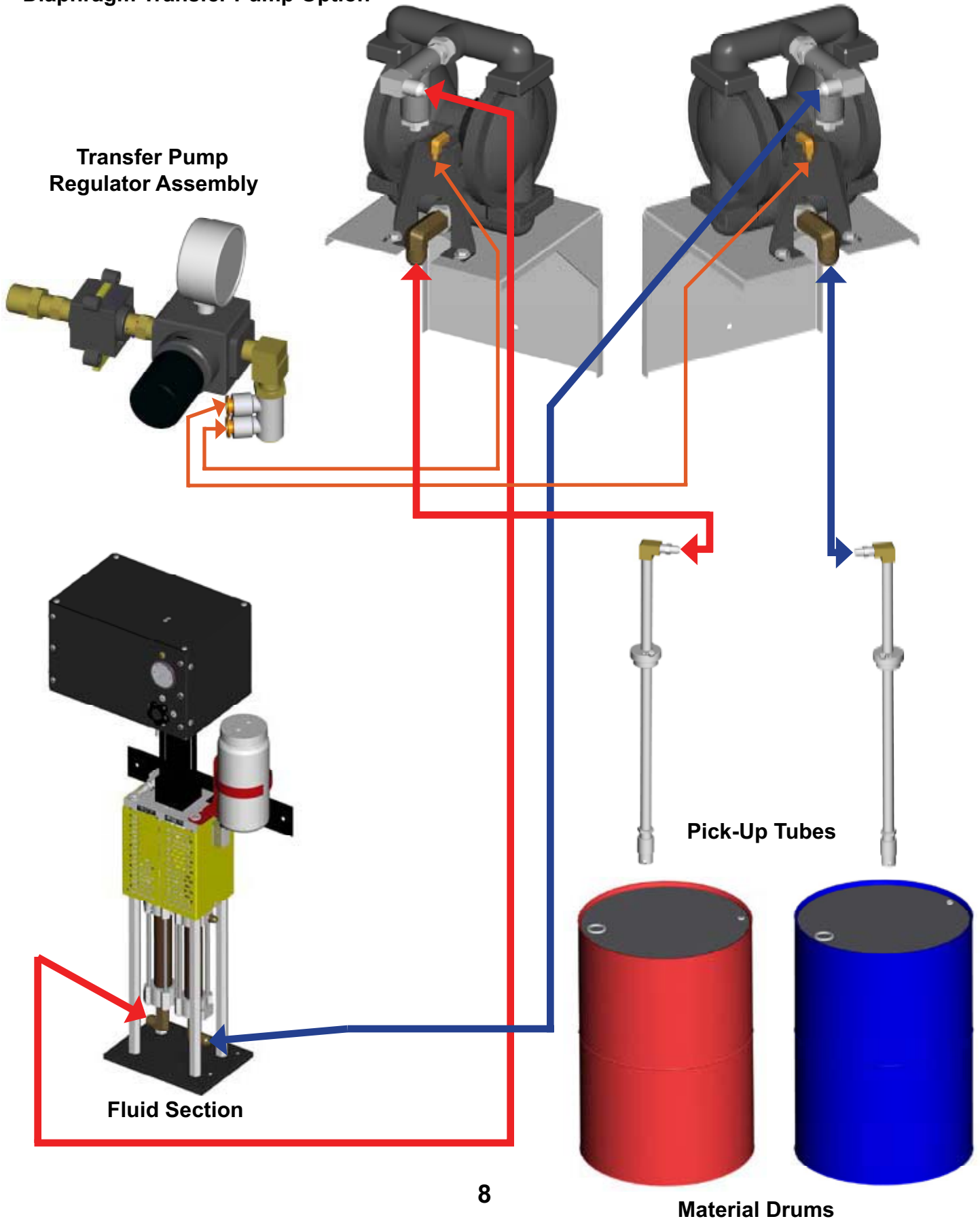

# Section 1 - Installation: Equipment Assembly

## Stick Transfer Pump Option

Sec. 1:4

Transfer Pump  
Regulator Assembly

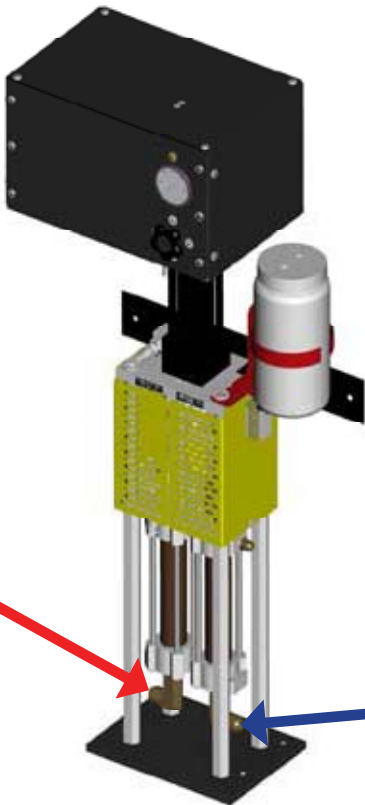
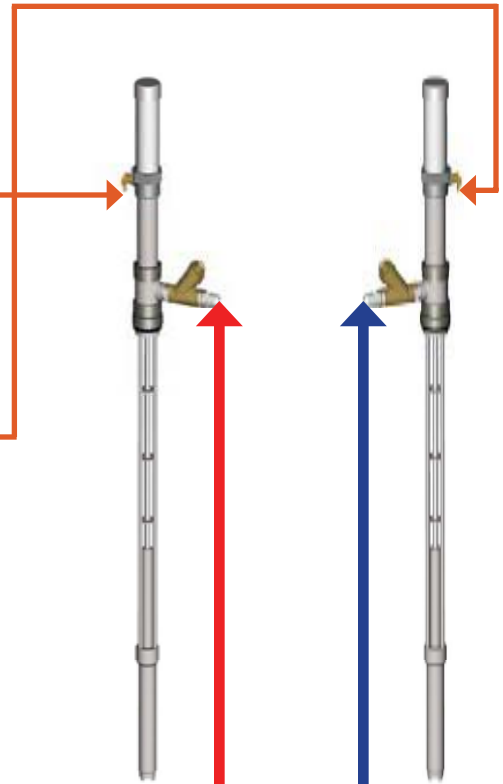
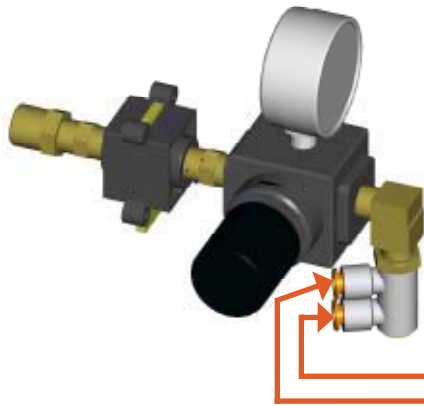

Fluid Section

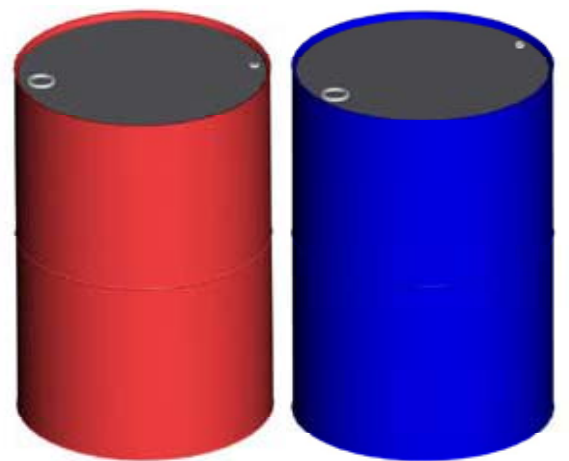

Material Drums

## Section 1 - Installation: Equipment Assembly

Sec. 1:4

Gun / Fluid Section  
Regulator Assembly

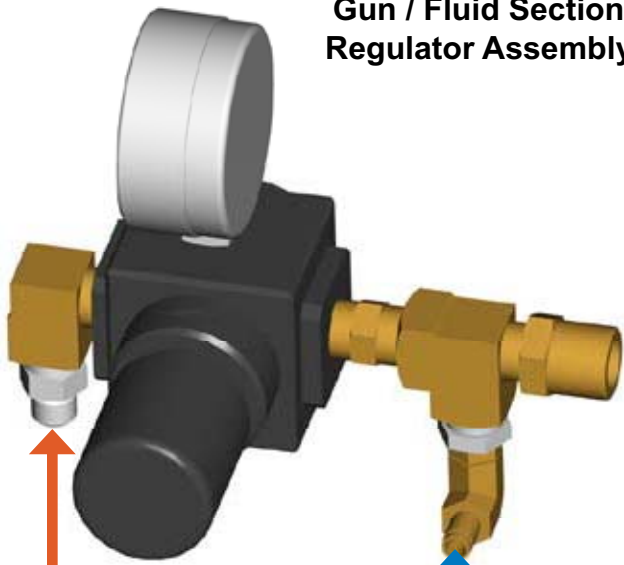

Supplied trigger air line  
from the main hose assembly

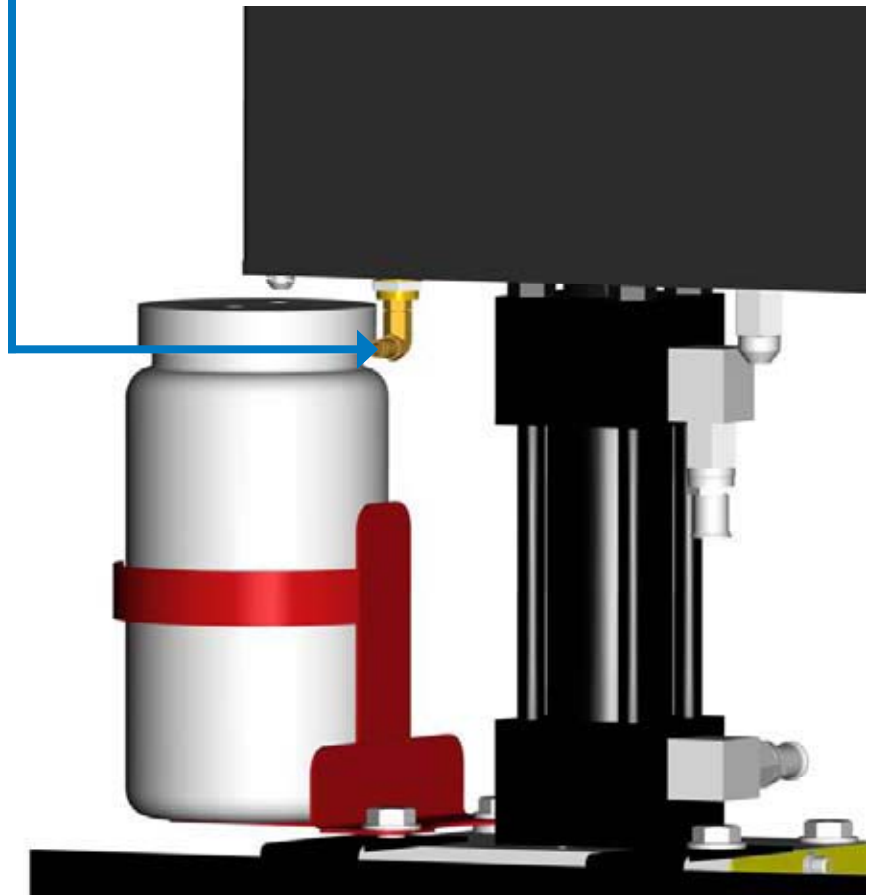

Fluid Section

## Section 1 - Installation: Equipment Assembly

Extension cord p/n: 22826-16 from the bottom of the control box. (refer to point to point diagram)

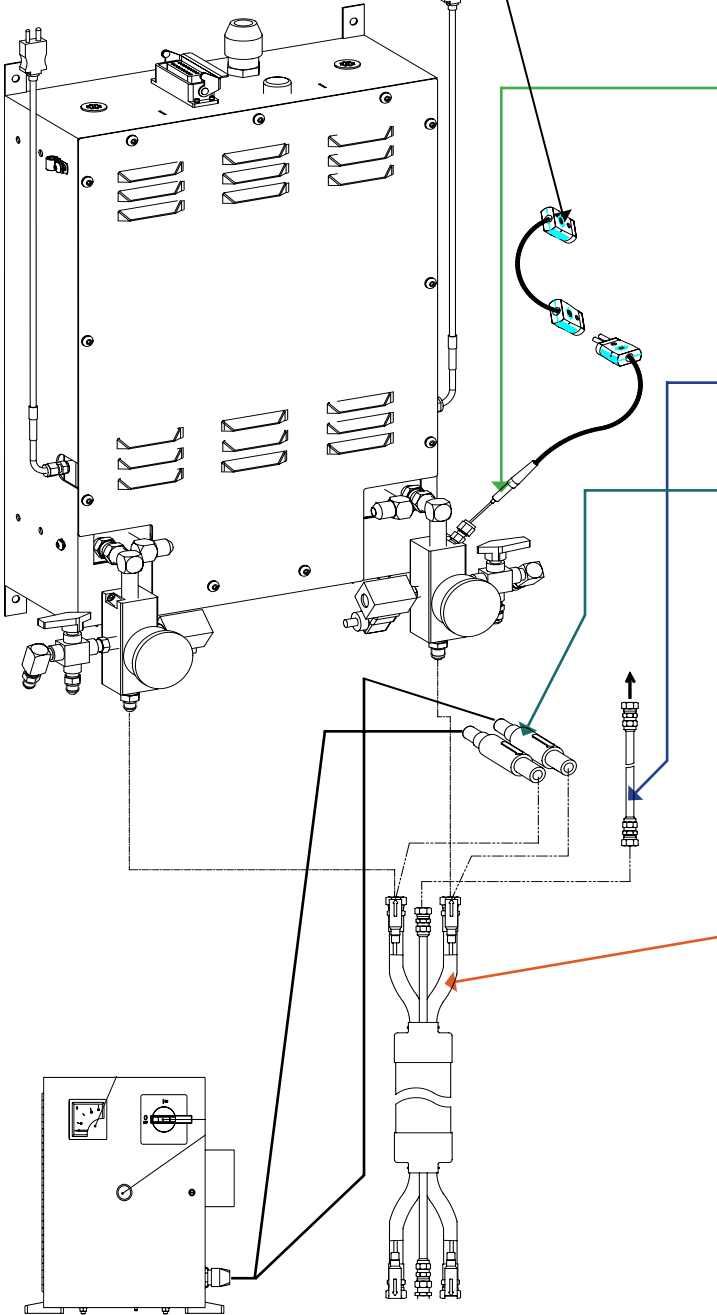

5. Connect hose assembly, p/n: 19524-01 to the front of the heater box module. The fittings are sized differently and will attach only one way. (match like sized fittings).

6. Install thermocouple at tee fitting.  
a. Feed 12' line through hose.  
b. Nut & Ferrules will lock into fitting.  
c. Tighten nut 1-1/4 turns past finger tight.  
d. Plug thermocouple into control box.

**Note:** When replacing thermocouple p/n: 21874-00 use kit p/n: 21214-01.

7. Connect supplied trigger air line to the air line on the hose assembly.

8. Connect the twist-lock plugs from the transformer module to the plugs on the hose assembly.

### CAUTION

*Hose assemblies are constructed of durable, rugged materials, however they are not indestructible. To provide precisely controlled heated material, the hoses have electrical wiring wrapped between layers. Avoid dragging hoses over or around sharp, abrasive edges and corners. Exercising caution and common sense will give long, and reliable service from the hoses.*

## Section 1 - Installation: Equipment Assembly

Sec. 1:4

9. Continue adding extra hose lengths if necessary.

### Required Tools:

Opened - end wrenches - 5/8", 3/4", 13/16"

a. Lay hoses out straight.

b. Couple hoses together with supplied union fittings and tighten finger-tight.

c. • Hold crimp fitting hex (3/4"), and union fitting together, allowing the hose to hold it's natural line.

- Using the appropriate wrench (A-side 3/4" / B-side 13/16") tighten swivel fitting to union, not allowing crimp fitting or union to turn. Repeat on opposite side of union.

**This practice is required on all connection points.**

**1) Hose @ machine**

**2) Hose @ gun**

**3) Adding additional hose sections**

d. Plug hoses together, The TRU-FLOW hose plugs are a twist-lock design.

- Push plugs together.
- Twist to lock position.

**Once connections are made, tape connections well enough to keep plugs from coming undone, damaged, etc.**

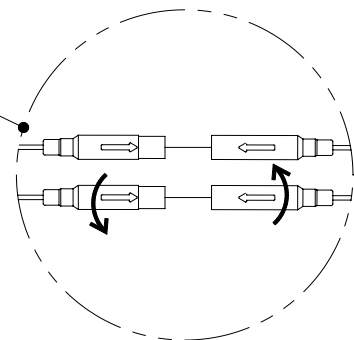
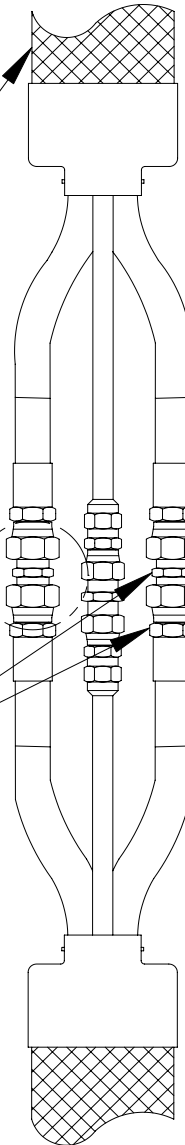

# Section 1 - Installation: Equipment Assembly

10. Connect the whip hose assembly to the last section of material hose.
11. Connect jumper p/n: 22094-00 to the plugs on material hose to complete the circuit.

 Jumper not needed with 18006-01 heated whip hose.

12. Connect Hose Assembly and the gun as shown. The swivel fittings on the Hose assembly are sized differently and will attach only one way.
13. Fluid and air connections between the system and gun should now be complete and **tight**.

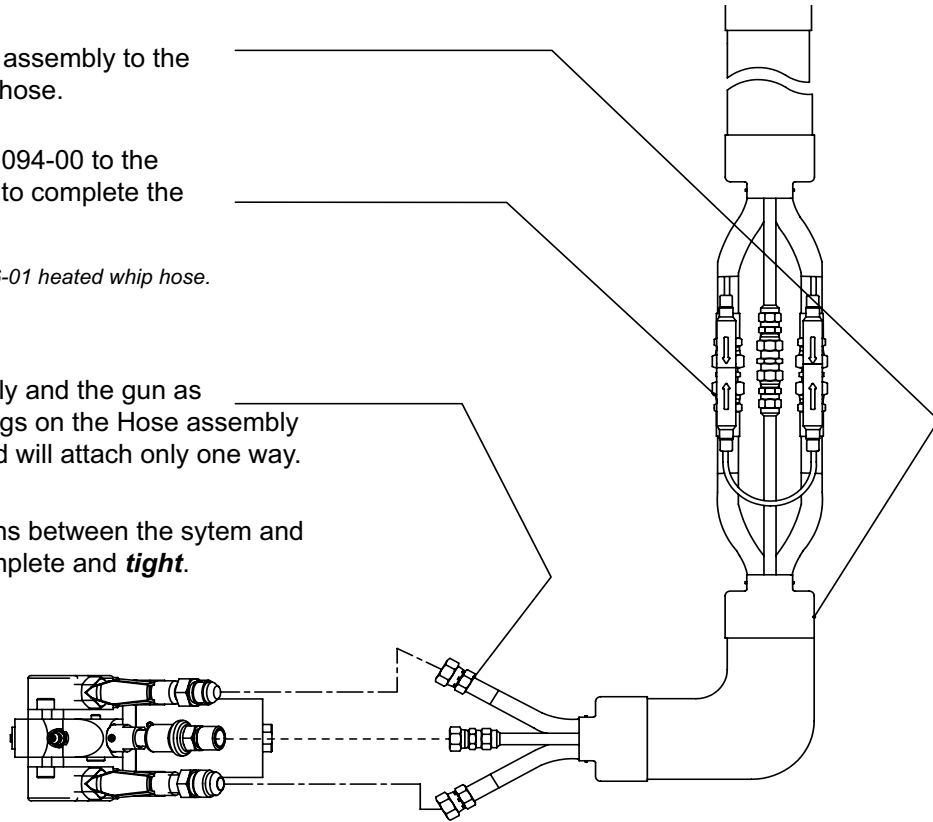

When Main Power to system console is on, the white and black wires in the console are **always live!** Disconnect or turn **off** Main Power source before opening console to make any repairs or before making any electrical repair of any type to the system.



If you do not understand the electrical hook-up described above, consult your local GlasCraft distributor OR a qualified electrician.

 Electrical connections must be checked on a periodic basis.

- 208/240 volt single phase
- L1 L2 GROUND
- 208/240 volt three phase
- L1 L2 L3 GROUND
- 380 volt three phase
- L1 (black)
- L2 (brown)
- L3 (black)
- L4 (blue)
- GROUND (green)

14. If more than 50 ft. of hose is used the transformer tap setting will need to be set for proper hose length. The sticker on the front cover will say which tap to move the wire to. **DO NOT MOVE THE COMMON LEG!**

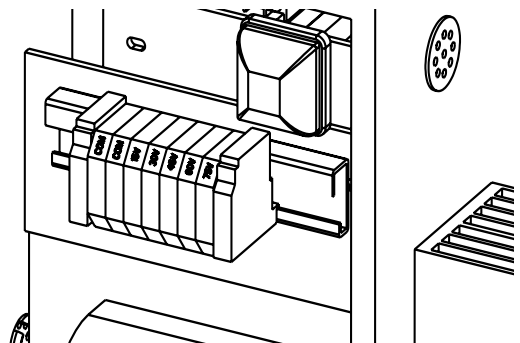

CONNECTIONS		HOSE LENGTH
	15V	50 FT
	30V	100 FT
	COM	150 FT
	45V	200 FT
(DO NOT MOVE)	60V	250 FT
	60V	250 FT
	75V	300 FT

## Section 1 - Installation: Equipment Assembly

15. Fill the hydraulic power pack with proper fluid.

 The hydraulic pack tank is empty when shipped from GlasCraft. The tank **MUST** be filled before operation. **Tank Capacity: 20 GAL. / 75.5 Liter.**

 Recommended Hydraulic Fluid: ISO grade 32, 46, or 68. Fluids containing anti-wear additives are recommended for optimum service life.

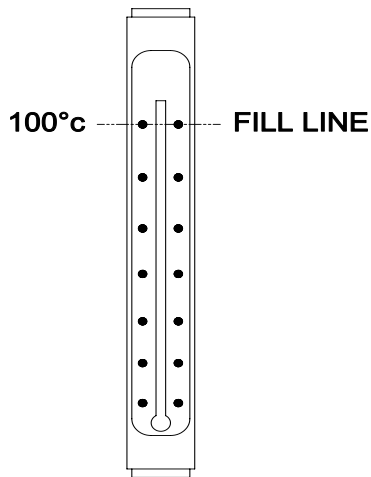
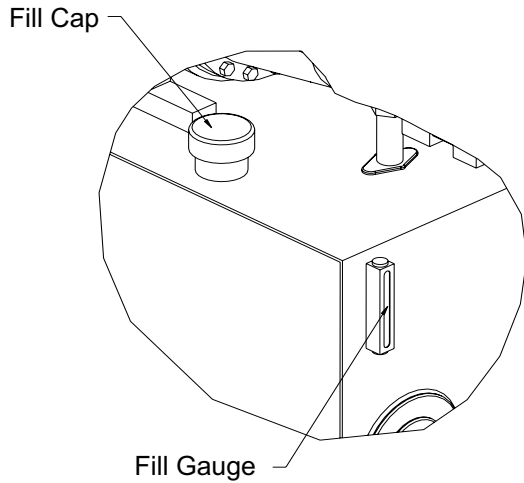

16. Fill the ISO pump lube bottle on top of the fluid section with DBP or material supplier's recommended lubricant.

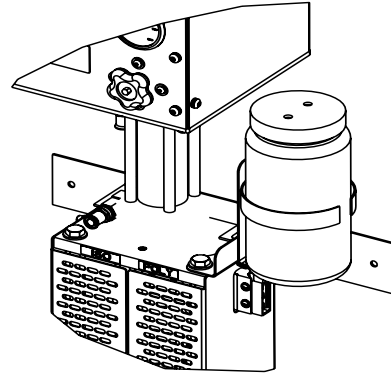



## Section 2 - Operation: Start-Up Instructions

### System Console

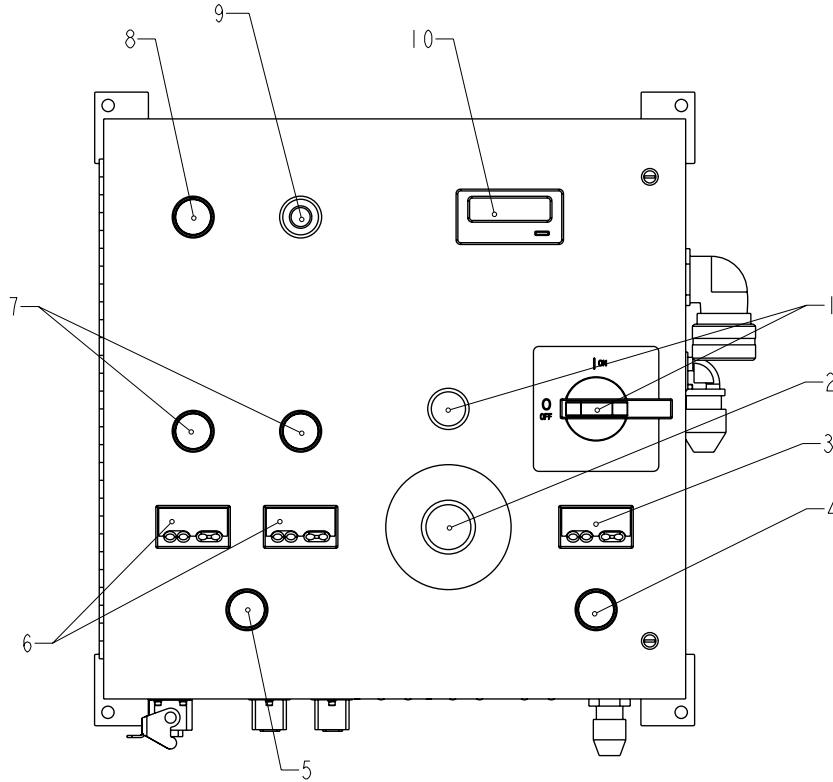



1	MAIN POWER SWITCH	Controls power and door; handle must point 1 to energize power , handle must point to 0 to open control box door. White pilot indicates when lighted, that the main power is on.
2	EMERGENCY STOP PUSH BUTTON	To stop all functions, push down on red button. To reset, turn handle on push button. All functions will remain off until main power switch has been switched off and back on
3	HOSE TEMPERATURE CONTROLLER	Controls temperature of liquid inside the heated hoses. To set desired temperature, press the up or down button until you reach desired temperature From this point, the temperature control is completely automatic.
4	ON PUSH BUTTON	Powers the controller. It requires 10 seconds for the Controller to respond.
5	ON PUSH BUTTON	Powers the controller. It requires 10 seconds for the Controller to respond.
6	ISO / POLY TEMPERATURE CONTROLLER	Controls temperature of liquid inside ISO heater. To set desired temperature, press the up or down button until you reach desired temperature. From this point, the temperature control is completely automatic.
7	OVER-PRESSURE RESET BUTTONS	When over-pressure is detected, the hydraulic power pack will be shut down, and will remain off until pressure is reduced and the push button is reset.
8	ON PUSH BUTTON	Power On To the hydraulic power pack.
9	OFF PUSH BUTTON	Power Off to the hydraulic power pack.
10	COUNTER	Counts pumps cycles. .042 GPC / .021 GPS

## Section 2 - Operation: Start-Up Instructions

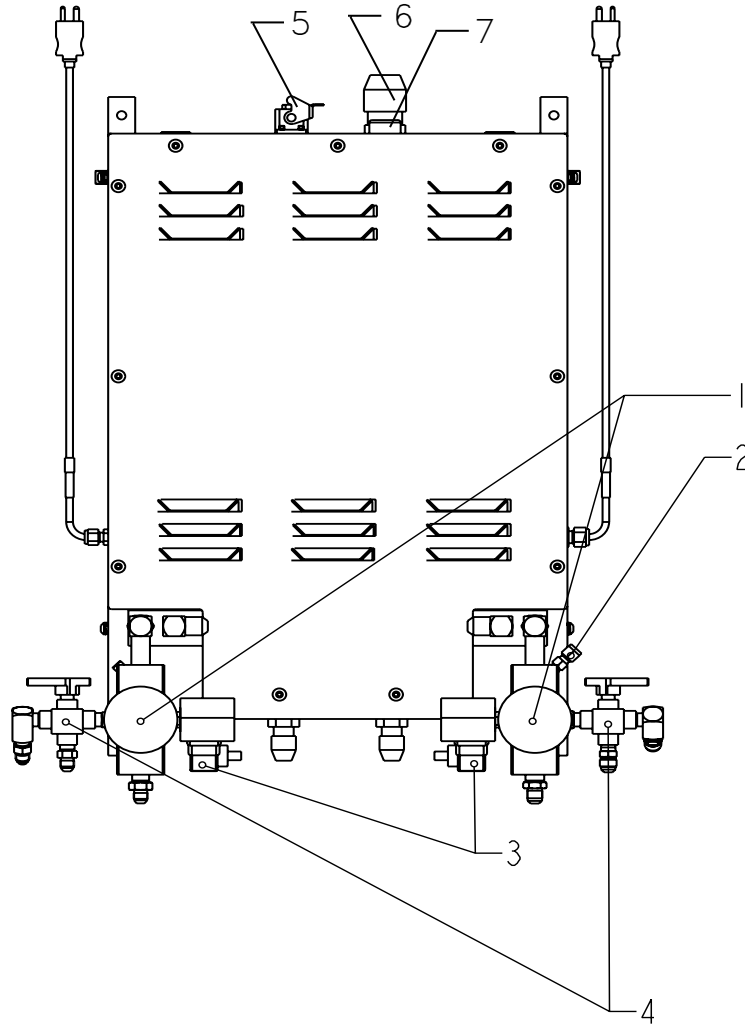
System Console

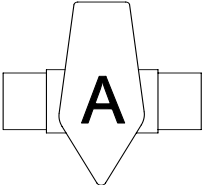

1	PSI GAUGES	Monitors ISO / POLY material pressure
2	THERMOCOUPLE FITTING	Thermocouple wire is feed through here to monitor material temperature.
3	OVERPRESSURE SWITCHES	Monitors ISO / POLY material overpressure.
4	RECIRCULATION VALVE	Controls material flow.  <div style="display: flex; flex-direction: column; align-items: center;"> <div style="display: flex; align-items: center; margin-bottom: 10px;">  <div style="margin-left: 10px;"><b>B</b> Valve open to recirculate through the gun block.</div> </div> <div style="display: flex; align-items: center; margin-bottom: 10px;">  <div style="margin-left: 10px;"><b>A</b> Normal operation, valve off.</div> </div> <div style="display: flex; align-items: center;">  <div style="margin-left: 10px;"><b>C</b> Valve open to recirculate through the heaters.</div> </div> </div>
5	CONTROL CABLE	16 Pin plug.
6	POWER CORD	Inlet cord grip for power cable.
7	POWER LAMP	Indicates power is supplied to the cabinet.

## Section 2 - Operation: Start-Up Instructions

Sec. 2:1

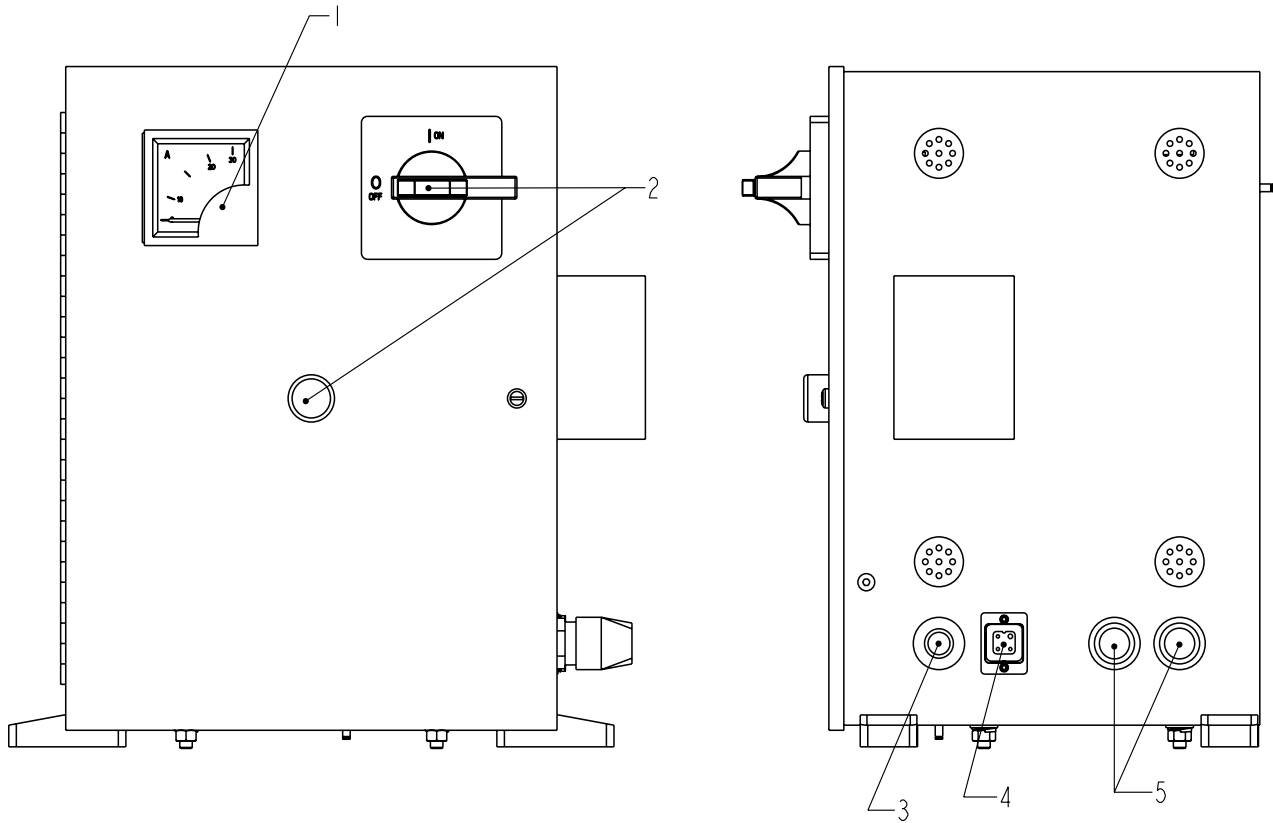

1	AMMETER	An instrument for measuring amperes to the primary side of the hose's transformer.
2	MAIN POWER SWITCH	Controls power and door; handle must point 1 to energize power, handle must point to 0 to open control box door. White pilot indicates when lighted, that the main power is on.
3	MAIN POWER CORD	Inlet cord grip for the main power.
4	CONTROL CABLE PLUG	4 pin plug.
5	HOSE POWER CABLES	Inlet cord grips for hose power cables.

## Section 2 - Operation: Start-Up Instructions

Sec. 2:1

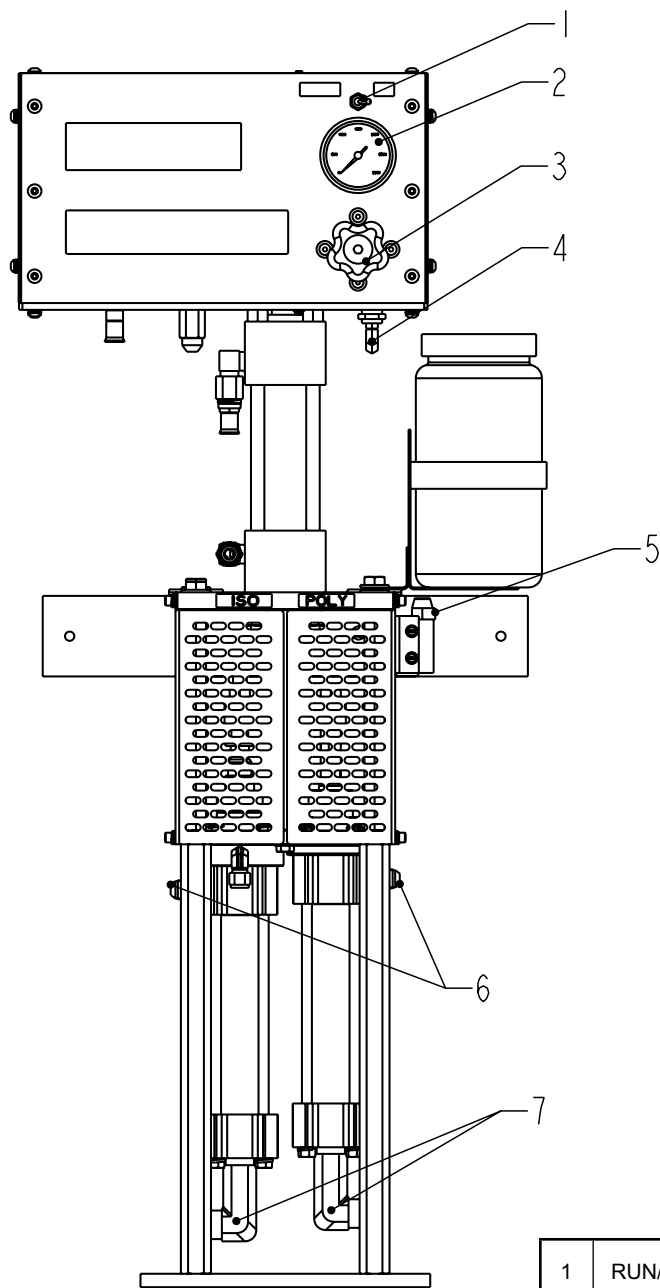

1	RUN/RETRACT SWITCH	The retract switch places the material pumps in the full "down stroke" position.
2	PSI GAUGE	Hydraulic pressure gauge.
3	REMOTE VALVE	Hydraulic pressure adjustment.
4	AIR CONNECT ELBOW	Air inlet elbow fitting.
5	COUNTER CABLE BOOT	Rubber boot for the counter cable.
6	OUTLET FITTINGS	Material pump outlet fittings.
7	INLET FITTINGS	Material pump inlet fittings.

## Section 2 - Operation: Start-Up Instructions

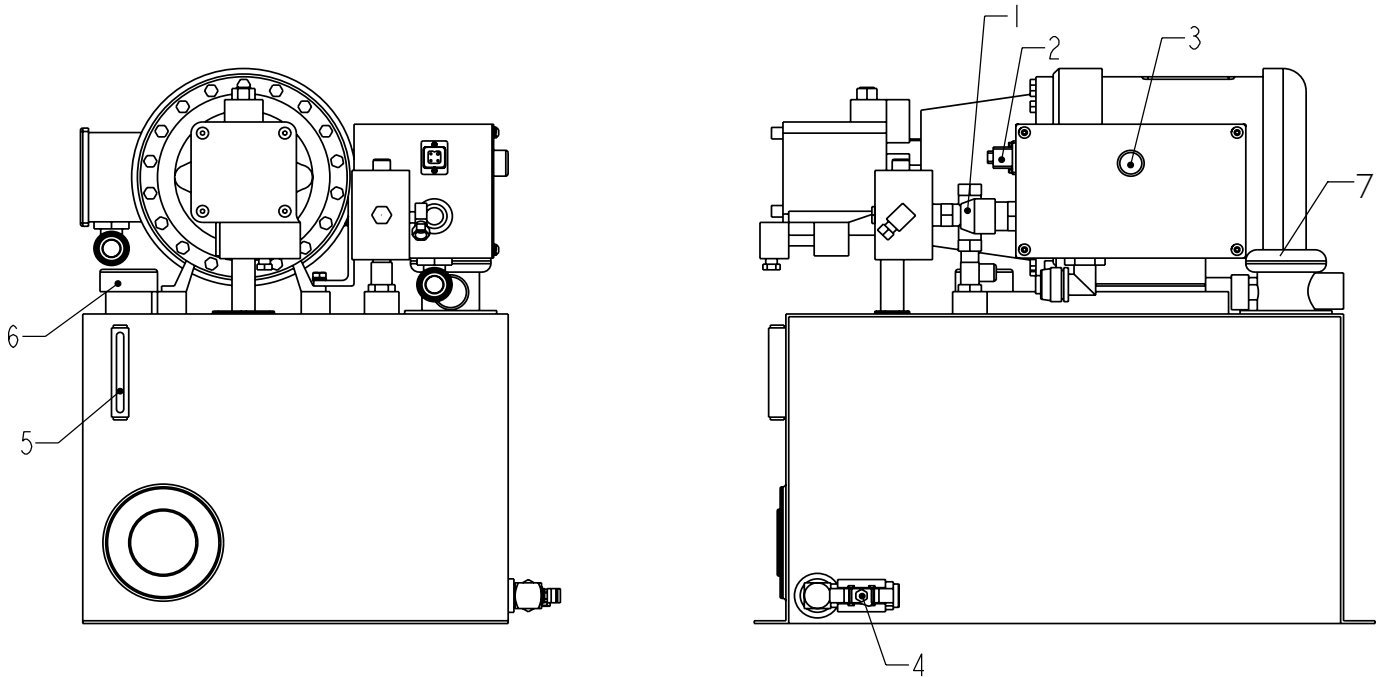

1	POWER CABLE	Inlet cord grip for the power cable.
2	CONTROL CABLE	4 pin plug.
3	POWER LAMP	Indicates power is on.
4	DRAIN VALVE	Open the valve to drain the hydraulic oil.
5	FILL LEVEL GAUGE	Monitors the Hydraulic oil level when filling.
6	FILL PORT	Remove cap to fill the tank with hydraulic oil.
7	FILTER HOUSING	Cartridge filter.

## Section 2 - Operation: Start-Up Instructions



Never leave machine unattended while system power is on or system is running.

System running is defined as: preheat cycle of the hose heat, primary heaters, or any pump operation.

Machine operators must be familiar with the component functions and operation of the machine.

### Pre-Operation Check List

- A. Check that all fittings are securely tight.
- B. Check electrical hook-up (qualified electrician recommended).
- C. Main power switch on Control Box should be switched to OFF position.



Do not place any part of the body in the path of the material spray.

Do not point the gun at or near other personnel.

Do not look into the Mixing Chamber orifice at any time.

Because of the hazardous materials used in this equipment, it is recommended that the operator use an air mask, goggles, protective clothing, and other safety equipment as prescribed by current regulations, recommendations of the chemical suppliers, and the laws in the area where the equipment is being used.

### Initial Start-Up Procedure

The system is now ready for start-up.

### Filling The System

1. Start the generator and air-compressor (If a gas powered air-compressor is being used). Refer to your generator/air-compressor manual for proper start-up and shut-down.
2. The system is now ready to be filled with material. With transfer pumps in place, adjust regulators on transfer pumps to 30-50 psi or until the pumps begin cycling, once the pumps begin loading up (cycle rate slows or stops) increase transfer pump air pressure to 100 psi. to fill the system.

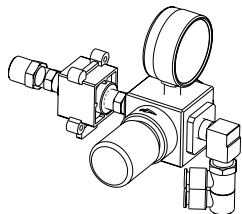

If the transfer pumps can not move material adequately enough to properly prime the system it may be necessary to start the hydraulic power pack.

- a. Ensure the hydraulic pressure knob is turned completely **counter clockwise**.

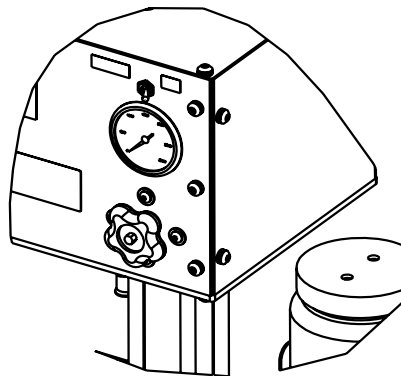

- b. Turn the main power switch to the "ON" position.

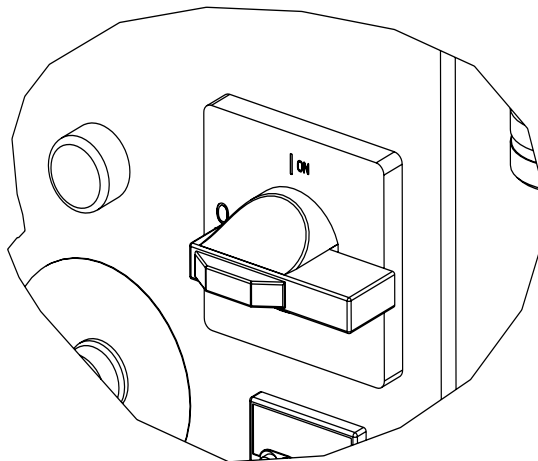

- c. Turn on the hydraulic power pack.

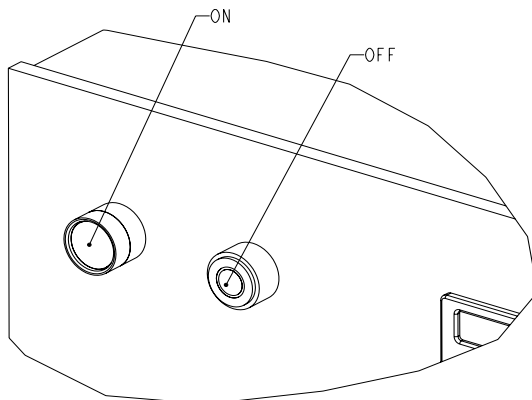

## Section 2 - Operation: Start-Up Instructions

- d. Flip retract switch to “run” position.

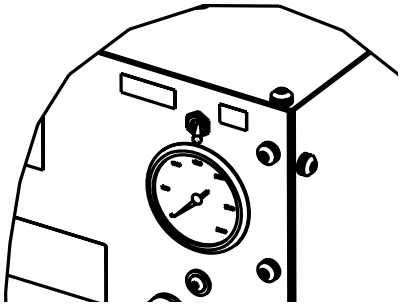

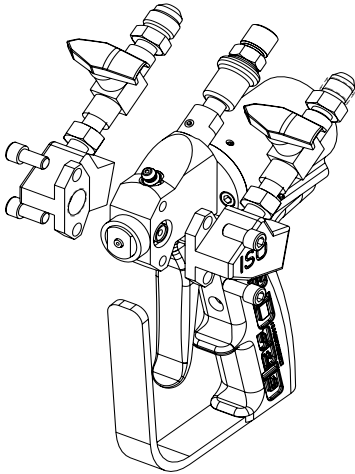

The pumps will begin cycling to completely prime the system

3. Remove ISO & POLY side blocks from gun.  
**MAKE SURE VALVES ARE OFF!**

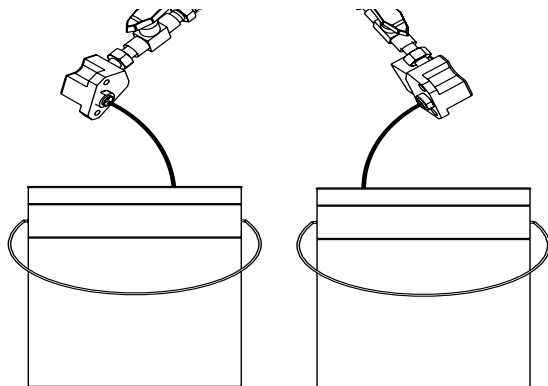

4. Place separate clean containers under each individual side block. Slowly open material valves (black arrow forward) on each side block to allow trapped air to escape the hose and material to flow into the containers until all air is purged from the material system.



 Remember to dispense one to two gallons of material to clear the system of grease and plasticizer that was used during factory testing.

5. Close manual material valves. Material pressure gauges should now register approximately equal pressure.  
6. Dispose of waste material properly and in accordance with chemical suppliers instructions and local, state and federal regulations.

 Before re-assembling the Side Blocks, lubrication can be applied by dabbing some white lithium grease into holes inside of the Gun Front Housing and wiping grease over the SideBlock Seals. Grease will purge itself when the air valve is turned on at the Gun and is triggered.

7. Clean and lubricate Side Blocks and Seals thoroughly and re-assemble on Gun. Make certain that Side Block Screws are tighten securely.  
8. Refer to material manufacturers operating instructions for proper preparation of material, i.e, mixers, etc.  
9. Turn main power Switch to the “ON” position, if the power is not all ready on from step “b”.

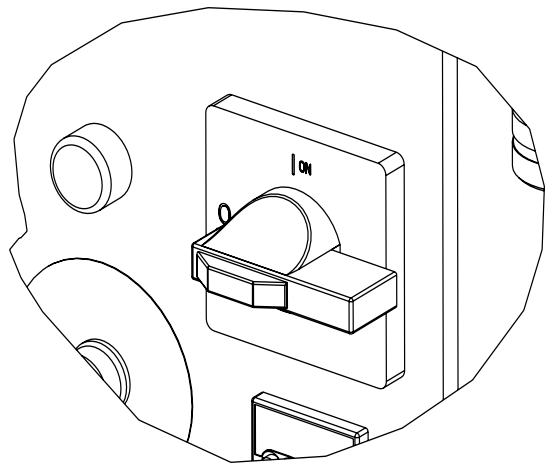

## Section 2 - Operation: Start-Up Instructions

- 10.** Turn on hose control:
- a. Push in the green button.
  - b. Press either up or down arrow buttons on the controller until desired temperature setting is achieved.

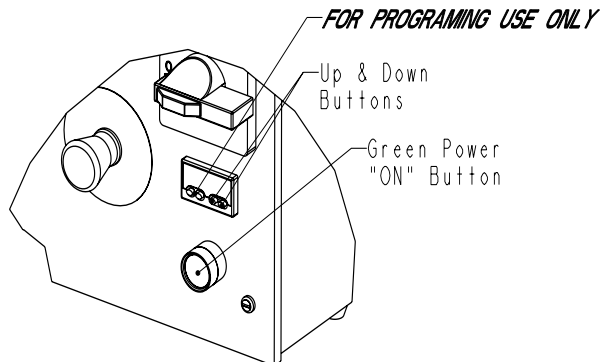

- 11.** Turn on the ISO & POLY Heaters.

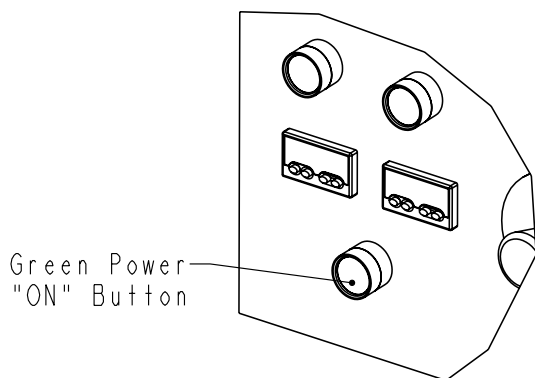

- 12.** Turn on Hydraulic Power Pack

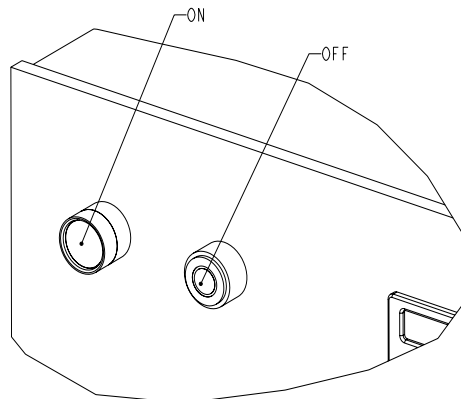

Allow enough time for hose to warm up (approximately 30 minutes). Remember that the heated hose does not have a delta rating. The heated hose's function is to maintain the heat generated by the primary heaters during system operation, and preheat material during initial start-up. The hose should be set to maintain a temperature close to the set point of the primary heaters.

To see the actual temperature of the liquid in the hose, push the blue button once and release. The actual temperature will then be displayed for 10 seconds.

- 13.** Adjust temperature to desired setting. ISO and POLY controllers function exactly the same as the hose controller.

Allow enough time for the material to be heated (approximately 3-5 minutes).

- 14.** Slowly adjust Hydraulic PRESSURE KNOB **clockwise** on the system to desired pressure.

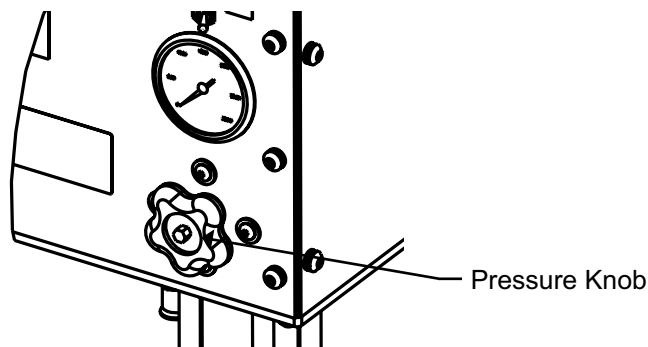

Turn transfer pump air regulator on slowly. Pumps should cycle slowly until hoses are full of material.



Straighten hose out flat, to avoid uneven heating and damage to internal wiring of the hose assembly.



## Section 2 - Operation: Start-Up Instructions

14. Turn purge air and material valves ON at the gun.

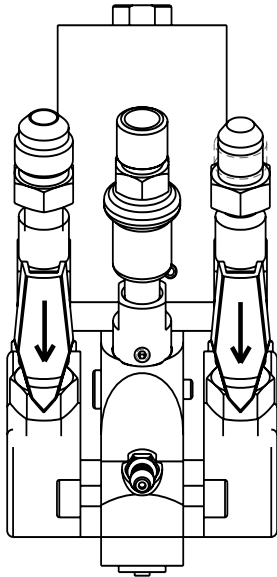

ON

16. Relieve any excess pressure by triggering the gun.

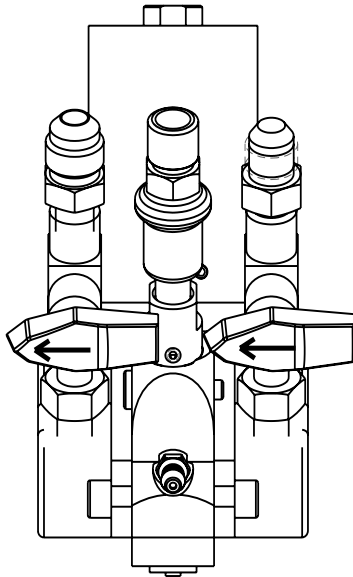

OFF

 The Emergency Stop Switch is located on the bottom right side of the Box Panel, when depressed, it will shut down the power and activate the Air Dump Valve. To reset, turn handle on push button.

17. The system is now ready for operation.

15. If one side registers considerably more pressure than the other side, go to the high pressure side and bleed off some pressure by slightly opening the manual material valve on the side block over the container. Bleed pressure until both sides are approximately the same pressure.

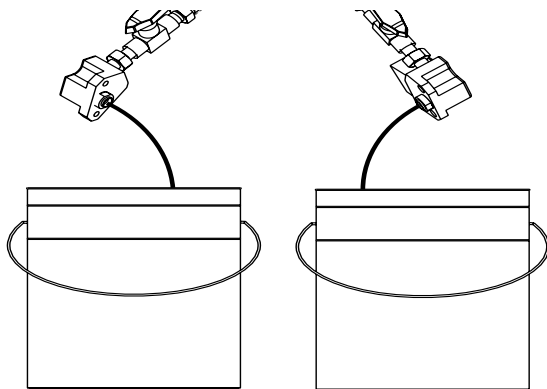

Material will dispense at high pressure. follow all safety precautions

## Section 2 - Operation: Shut-Down Instructions

### System Shut-Down

1. Flip "retract" switch from "run" position.

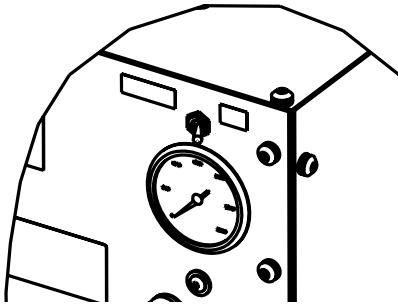

2. Trigger gun to send pumps into full downstroke.
3. Turn off hydraulic power pack.

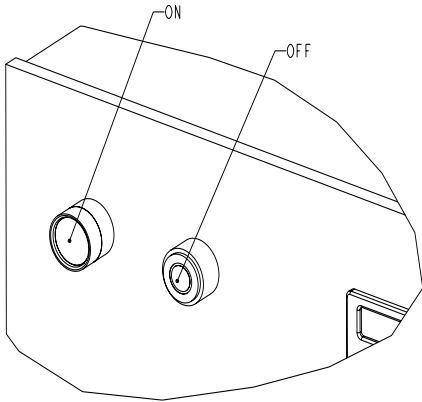

4. Turn off primary heaters.

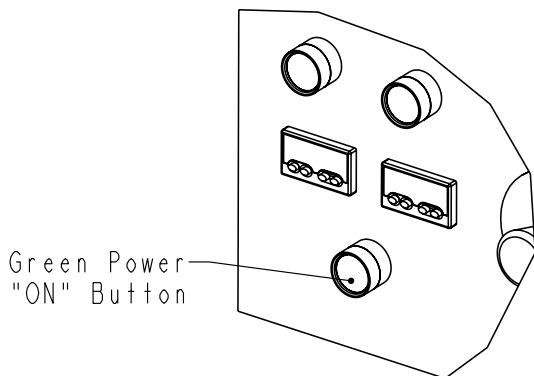

5. Turn main power switch to the "OFF" position.

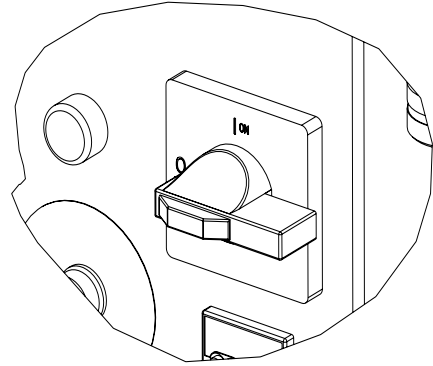

6. Refer to gun manual for proper Gun maintenance.
7. Reduce Hydraulic Pressure Knob setting to ZERO.
8. Visually inspect entire system for leaks.
9. Turn OFF System.



Leave 200-500 psi. on the material circuit.

### Storing The Hose

Coil the hose with a minimum diameter of 4', To avoid kinking and subsequent damage to the internal wiring of the hose assembly.

10. Shut down the generator and air-compressor (If a gas powered air-compressor is being used). Refer to your generator/air-compressor manual for proper start-up and shut-down

## Section 2 - Operation: Daily Start-Up Instructions

### System Daily Start-Up

1. Start-up the generator and air-compressor (If a gas powered air-compressor is being used). Refer to your generator/air-compressor manual for proper start-up and shut-down.
2. Uncoil hose.
3. Check desiccant dryer beads to insure they are still purple and have not changed to pink.
4. Check the ISO pump lube bottle on top of the fluid section and add DBP or material supplier's recommended lubricant if needed.

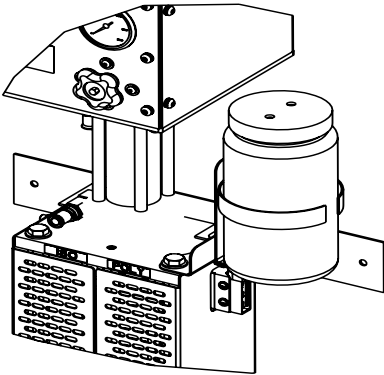

5. Check material screens at the gun and transfer pumps.
6. Start the drum mixer and let it run to material suppliers specifications.
7. Turn on the hose controller and set the temperature according to material supplier's specifications.

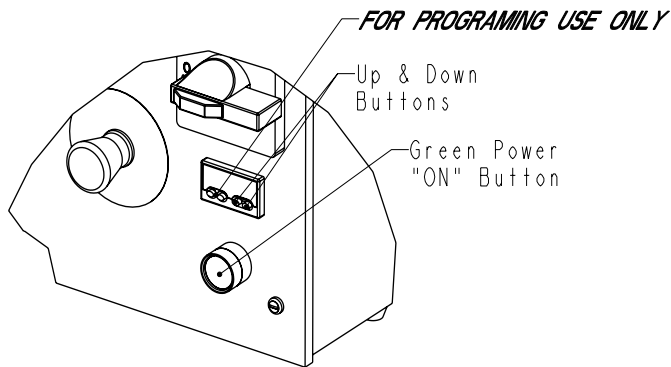

8. Once the hose temperature reaches 120°, It's ok to turn on the primary heaters and set temperature to material suppliers specifications.

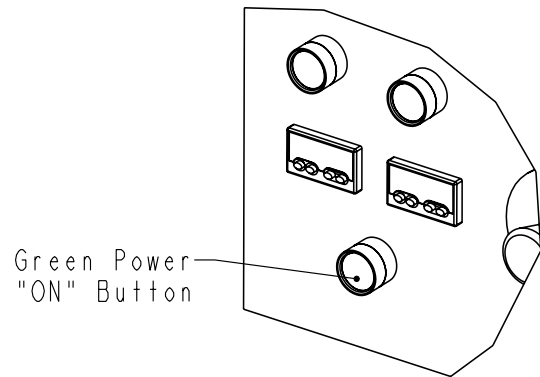

9. Flip retract switch to "run"

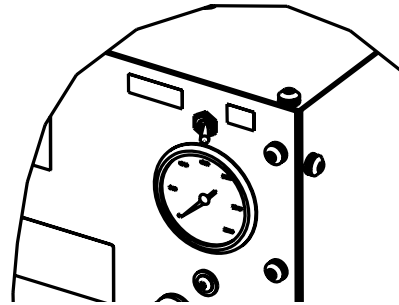

10. Increase Hydraulic pressure to desired pressure. Balance pressures if necessary.

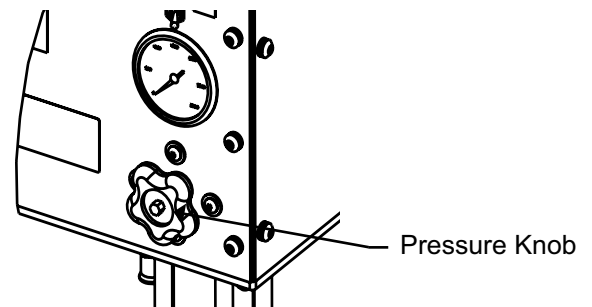

11. Perform prober / prober P2 side block seal integrity test.
12. Perform prober / prober P2 high-pressure ball valve test.
13. **READY TO SPRAY!**

# Section 3 - General Information: Sub Assembly Drawings

## 22870-XX Material Pump Assembly

GLASCRAFT P/N	A	B
22870-01	22145-05	22830-01
22870-02	22145-03	22830-02

Sec. 3:2

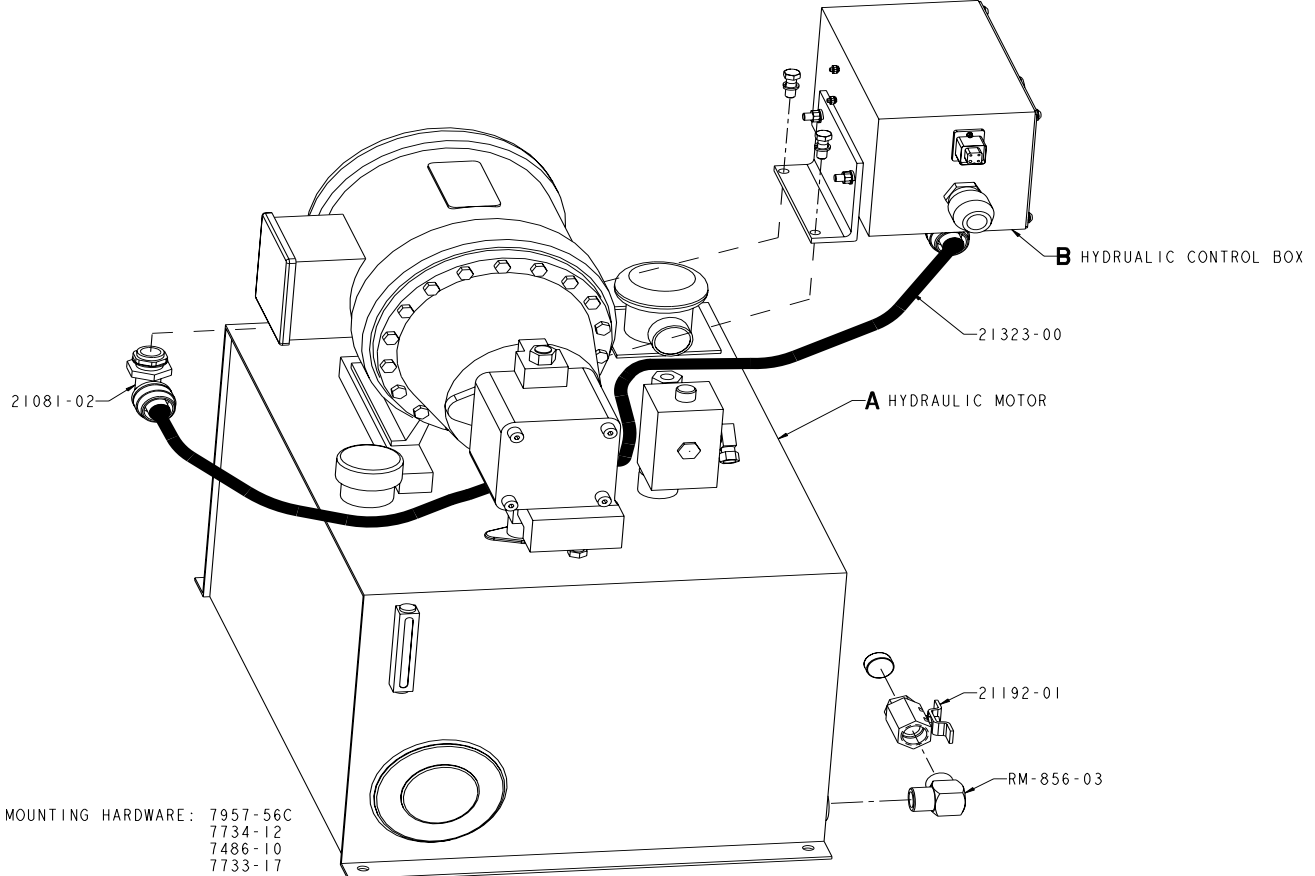
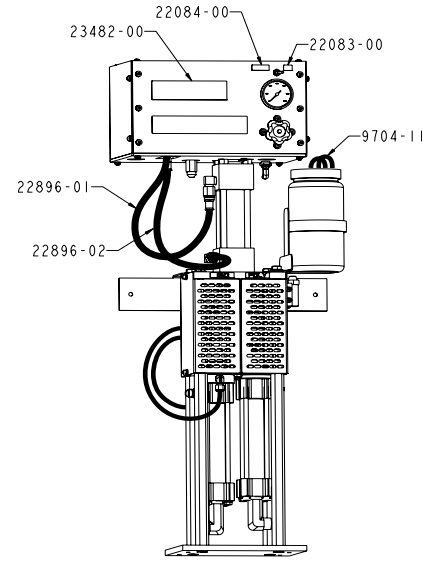
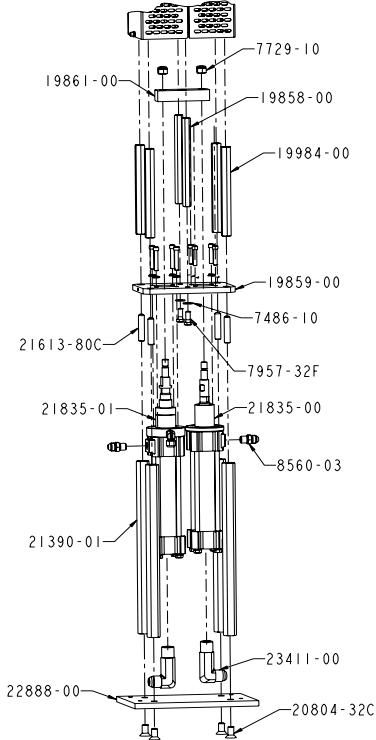
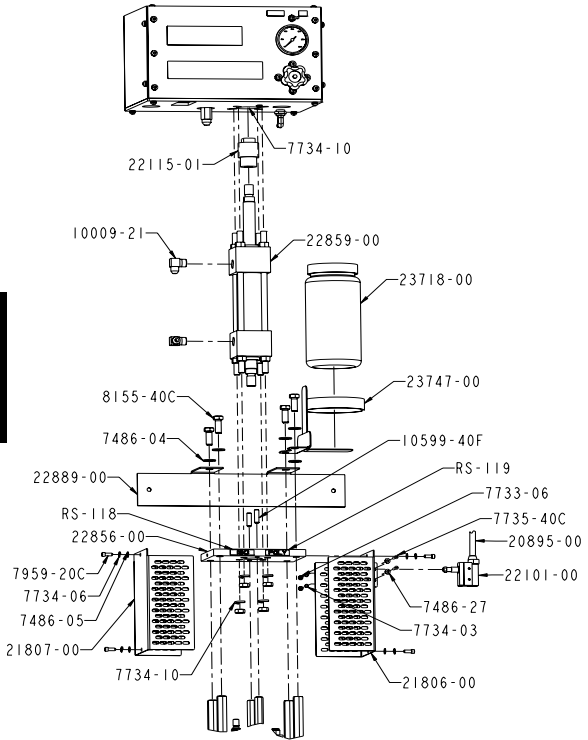

MOUNTING HARDWARE: 7957-56C  
7734-12  
7486-10  
7733-17

# Section 3 - General Information: Sub Assembly Drawings

## 22870-XX Material Pump Assembly

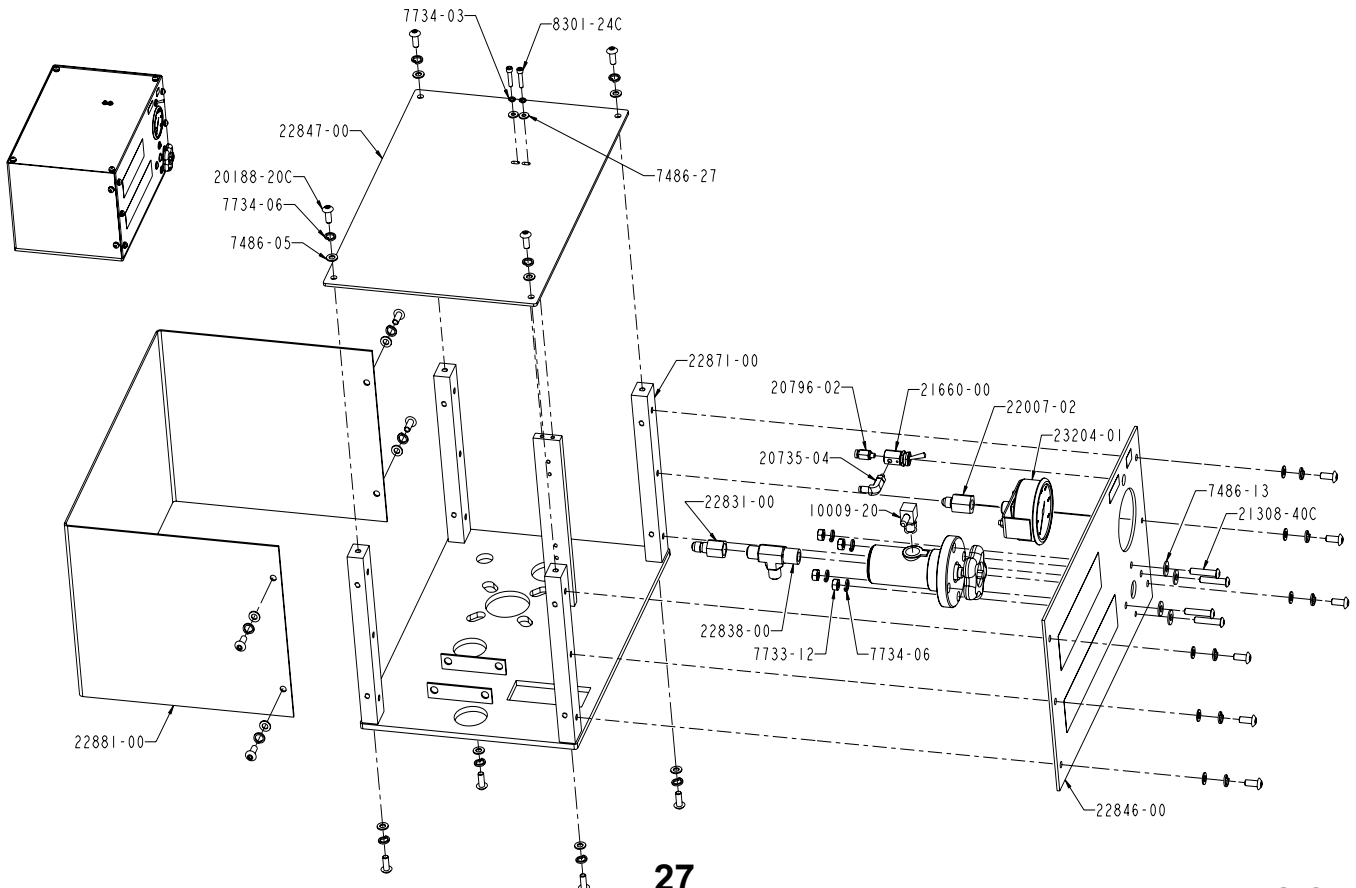
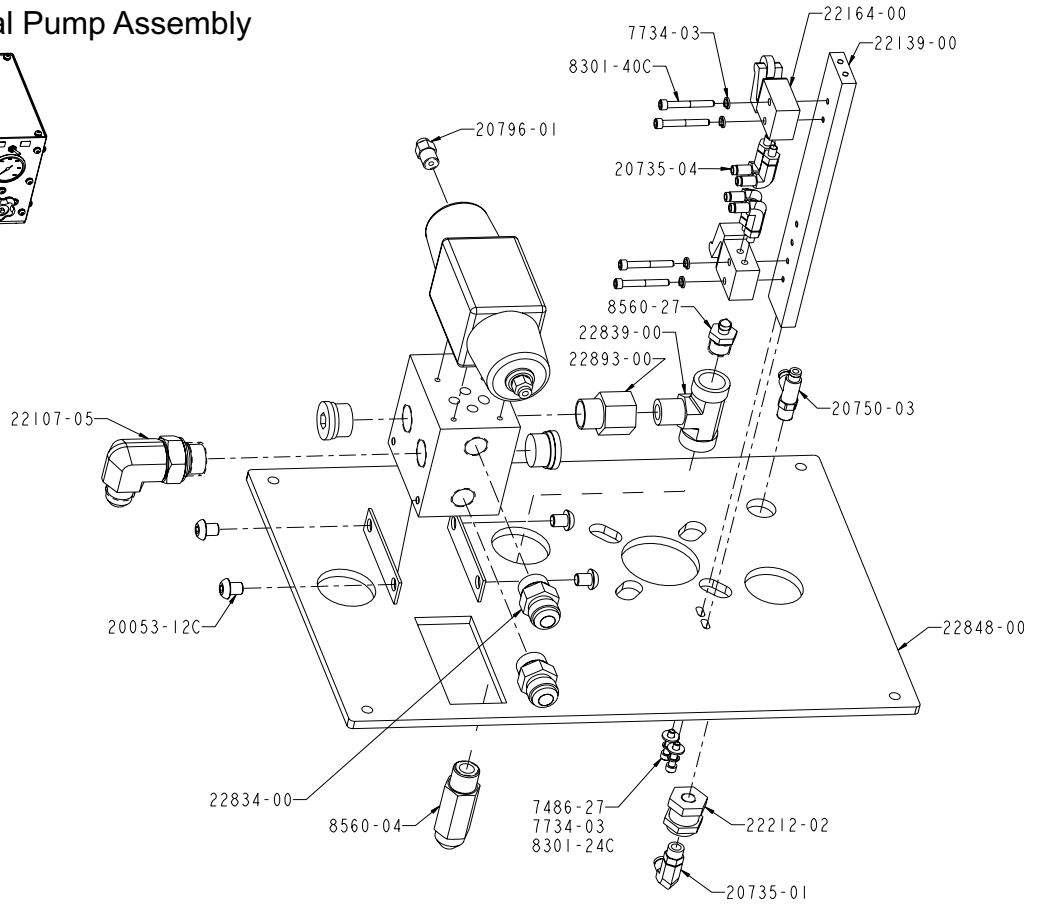
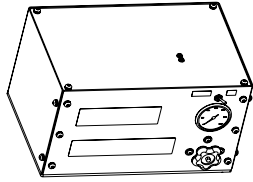

# Section 3 - General Information: Sub Assembly Drawings

22870-XX Material Pump Assembly

Sec. 3:2

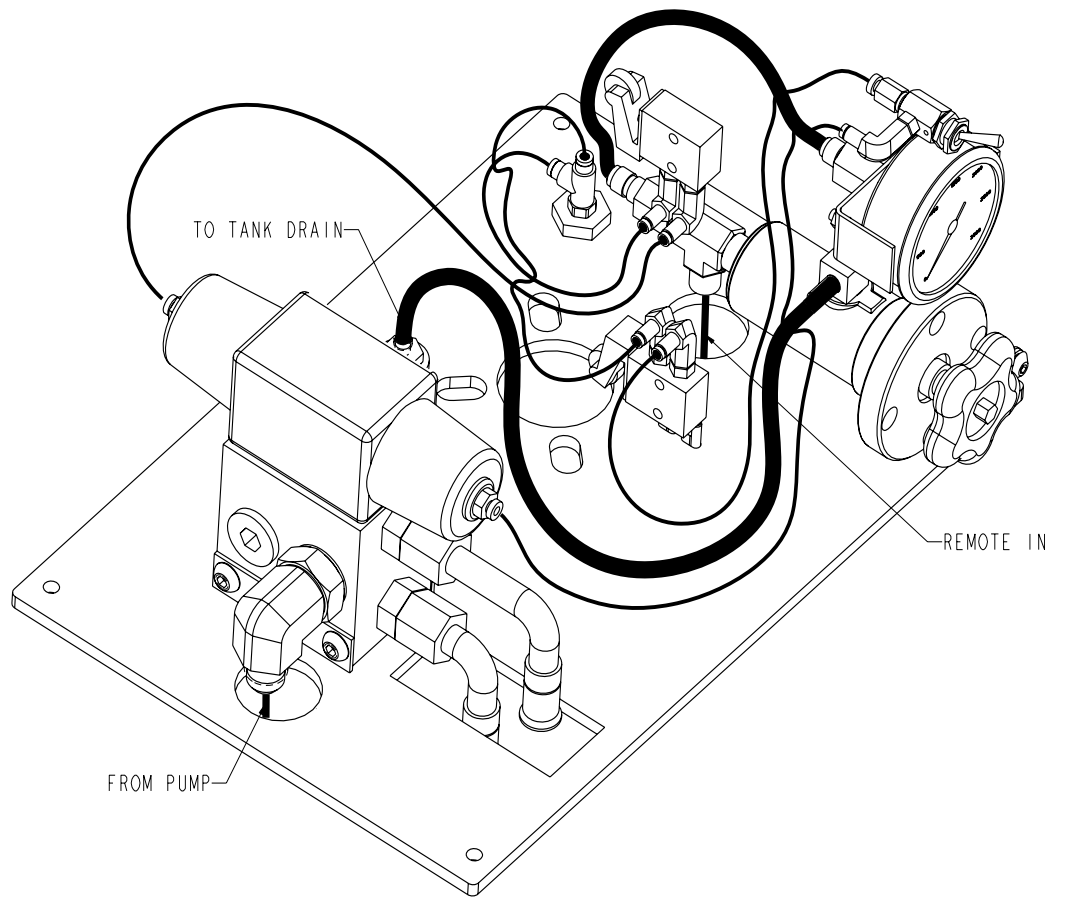
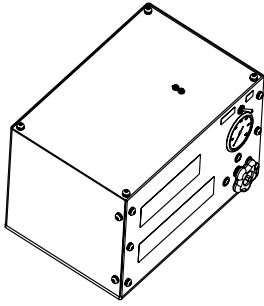

## Section 3 - General Information: Sub Assembly Drawings

### 22870-XX Material Pump Assembly

Part Number	Description	Qty.
RM-856-03	ELBOW FITTING	1
RS-118	ISO DECAL	1
RS-119	POLY DECAL	1
10009-02	ELBOW FITTING	2
10009-20	ELBOW FITTING	1
10599-40F	SCREW	2
19858-00	PUMP STANDOFF	2
19859-00	UNIVERSAL PLATE	1
19861-00	PUMP SADDLE	1
19984-00	AIR MOTOR STANDOFF	4
20053-12C	SCREW	4
20188-20C	SCREW	18
20732-03	TUBING	2 FT.
20735-01	ELBOW FITTING	1
20735-04	ELBOW FITTING	5
20796-02	FITTING	1
20796-04	FITTING	2
20804-56C	SCREW	4
21081-02	CONNECTOR	1
21192-01	2-WAY VALVE	1
21308-40C	SCREW	4
21323-00	FLEXIBLE CONDUIT	2.5 FT.
21390-01	AIR MOTOR STANDOFF	4
21613-80C	SET SCREW	4
21660-00	2-WAY VALVE	1
21806-00	LEFT GUARD	1
21807-00	RIGHT GUARD	1
21835-00	1:1 PUMP	1
21835-01	ISO 1:1 PUMP	1
22007-02	FITTING	1
22010-01	HOSE ASSEMBLY	2
22083-00	"RUN" DECAL	1
22084-00	"RETRACT" DECAL	1
22101-00	LIMIT SWITCH	1
22107-05	ELBOW FITTING	1
22115-01	CAM SHAFT ADAPTER	1
22139-00	MOUNTING BRACKET	1
22164-00	VALVE	2
22212-02	BULKHEAD FITTING	1
22831-00	REDUCER FITTING	1
22834-00	FITTING	2
22838-00	TEE FITTING	1
22839-00	TEE BRANCH FITTING	1
22846-00	FRONT CHANGEOVER PLATE	1

Part Number	Description	Qty.
22847-00	TOP CHANGEOVER PLATE	1
22848-00	BOTTOM CHANGEOVER PLATE	1
22856-00	TOP CYLINDER PLATE	1
22859-00	HYDRAULIC CYLINDER	1
22871-00	CHANGEOVER STANDOFF	4
22881-00	CHANGEOVER GUARD	1
22888-00	MOUNTING PLATE	1
22889-00	MOUNTING PLATE	1
22893-00	FITTING	1
22894-00	PLUG FITTING	2
22896-01	HOSE ASSEMBLY	1
22896-02	HOSE ASSEMBLY	1
23204-01	PRESSURE GAUGE	1
23411-00	ELBOW FITTING	1
23482-00	GLASCRAFT DECAL	1
23718-00	PLASTIC BOTTLE	1
23747-00	BOTTLE BRACKET	1
7486-05	WASHER	14
7486-05	WASHER	33
7486-07	WASHER	4
7486-10	WASHER	6
7486-13	WASHER	4
7486-27	WASHER	6
7729-10	HEX NUT	2
7733-06	HEX NUT	2
7733-12	HEX NUT	4
7733-14	HEX NUT	4
7733-17	HEX NUT	4
7733-34	HEX NUT	8
7734-03	HEX NUT	10
7734-06	LOCK WASHER	30
7734-07	LOCK WASHER	4
7734-12	LOCK WASHER	4
7735-40C	SCREW	2
7957-32F	SCREW	2
7957-56C	SCREW	4
7959-20C	SCREW	4
8155-40C	SCREW	4
8156-48C	SCREW	4
8301-40C	SCREW	4
8560-03	FITTING	2
8560-04	FITTING	1
8560-27	FITTING	1
9704-11	TUBING	6 FT.

Sec. 3:2





# Section 3 - General Information: Sub Assembly Drawings

## 22895-XX Control Box Assembly

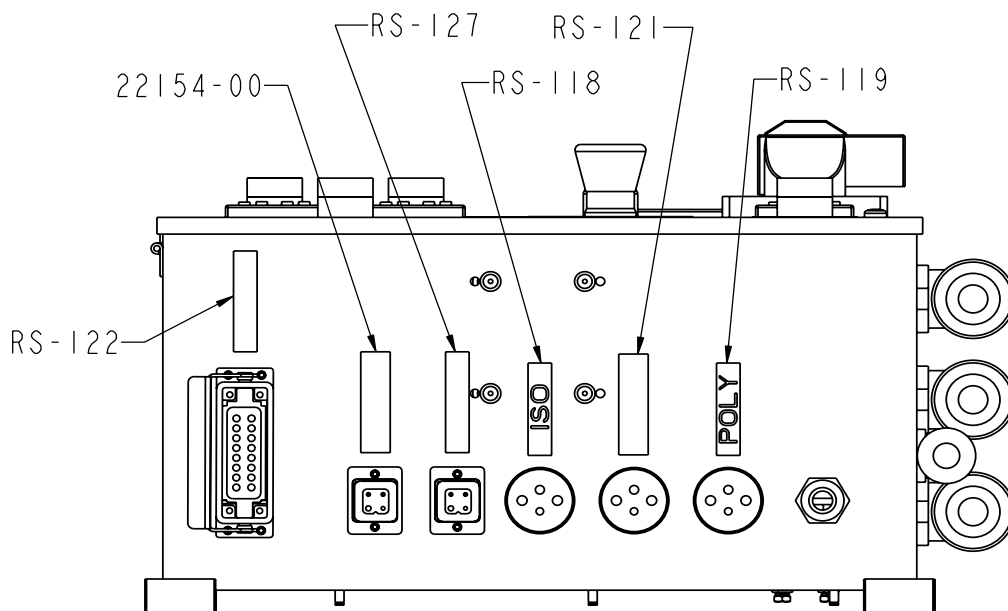
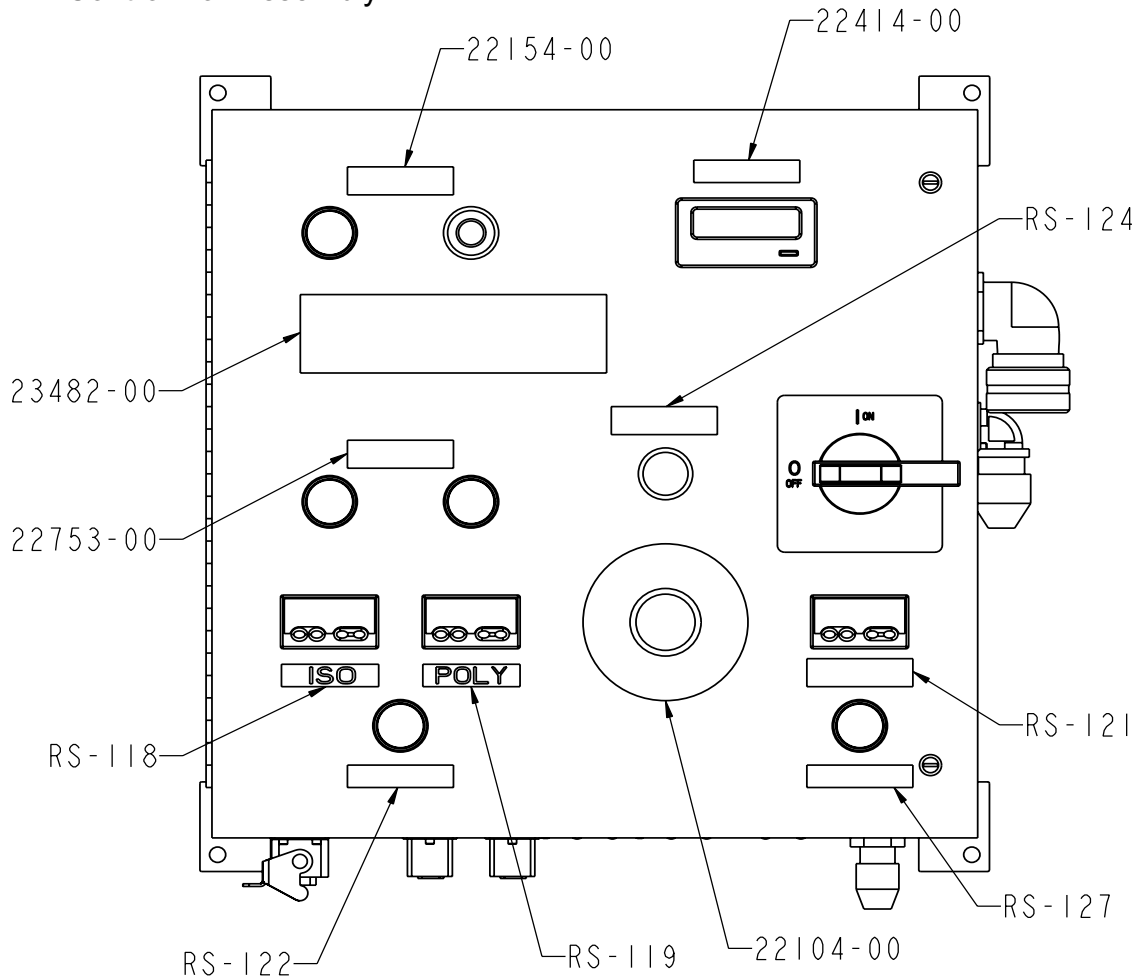

Sec. 3:2

## Section 3 - General Information: Sub Assembly Drawings

### 22895-XX Control Box Assembly

Part Number	Description	Qty.
RS-118	ISO DECAL	2
RS-119	POLY DECAL	2
RS-121	HOSE DECAL	2
RS-122	PRIMARY DECAL	2
RS-124	MAIN DECAL	1
RS-127	HOSE CONTROL DECAL	2
RS-141-02	CORD GRIP	1
T4-161-03	CABLE RELIEF	2
14638-02	RIVET	4
21112-00	LCD COUNTER	1
21284-16C	SCREW	8
21356-02	CONTROLLER	3
21586-03	CORD GRIP	1
21823-00	DIN RAIL	1.365
21824-16C	SCREW	6
21889-00	FUSEHOLDER	6
21892-01	FINDER RELAY	3
21893-01	SOCKET RELAY	3
21953-64	SELF-TAP SCREW	4
22104-00	EMERGENCY STOP DECAL	1
22142-00	TRANSFORMER	1
22154-00	HYDRAULIC POWER DECAL	2
22157-00	TERMINAL BLOCK	4
22158-00	TERMINAL BLOCK SPACER	4
22159-00	TERMINAL BLOCK COVER	1
22178-00	POWER SWITCH	1
22414-00	CYCLE COUNTER DECAL	1
22422-01	RELAY	2
22422-02	RELAY	1
22423-01	RELAY SOCKET	2
22423-02	RELAY SOCKET	1
22502-00	CIRCULAR PANEL JACK	2
22528-00	WIRING DUCT	2.5
22753-00	OVERPRESSURE DECAL	1

Part Number	Description	Qty.
22816-00	PANEL MOUNT HOUSING	2
22818-00	FEMALE CONNECTOR	2
22819-00	PANEL MOUNT BASE	1
22822-00	TERMINAL INSERT	1
22890-00	CONTROL BOX	1
22891-00	MOUNTING PAD, TOP	2
22892-00	MOUNT PAD, BOTTOM	2
23482-00	GLASCRAFT DECAL	1
5307-01	CONDUIT NUT	2
5307-03	CONDUIT NUT	3
7486-27	WASHER	6
7486-28	WASHER	4
7733-02	HEX NUT	8
7733-06	HEX NUT	6
7734-01	LOCK WASHER	8
7734-03	LOCK WASHER	6
8156-16C	SCREW	4
23070-00	LATCHED PUSHBUTTON	2
23071-00	LATCHED PUSHBUTTON	3
23072-00	MOMENTARY PUSHBUTTON	1
23073-00	EMERGENCY STOP	1
23079-01	OPEN CONTACT BLOCK	6
23079-02	CLOSED CONTACT BLOCK	5
23074-00	COUPLING PLATE	8
23075-02	INSCRIPTION CAP "O"	1
23075-03	INSCRIPTION CAP "R"	2
23075-04	INSCRIPTION CAP "I"	1
23075-05	INSCRIPTION CAP "I/O"	2
23076-01	YELLOW CAP	2
23076-02	CLEAR CAP	1
23076-03	GREEN CAP	2
23077-02	WHITE PILOT LIGHT	1
23078-01	YELLOW LED	2
23078-02	WHITE LED	1
23078-03	GREEN LED	2
23078-04	WHITE LED	1

Sec. 3:2

# Section 3 - General Information: Sub Assembly Drawings

22895-XX Control Box Generic Schematic

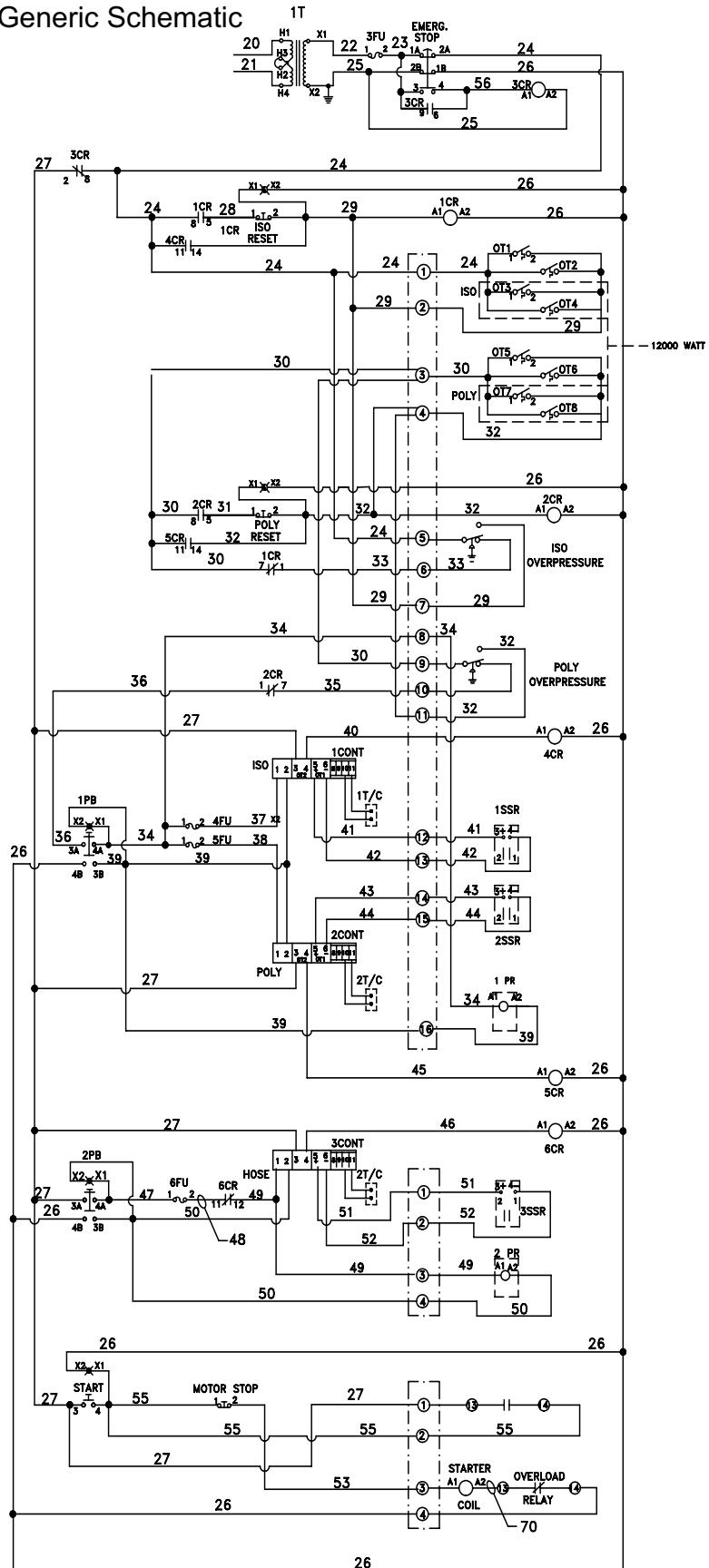

# Section 3 - General Information: Sub Assembly Drawings

## 22895-XX Control Box Schematic

Sec. 3:2

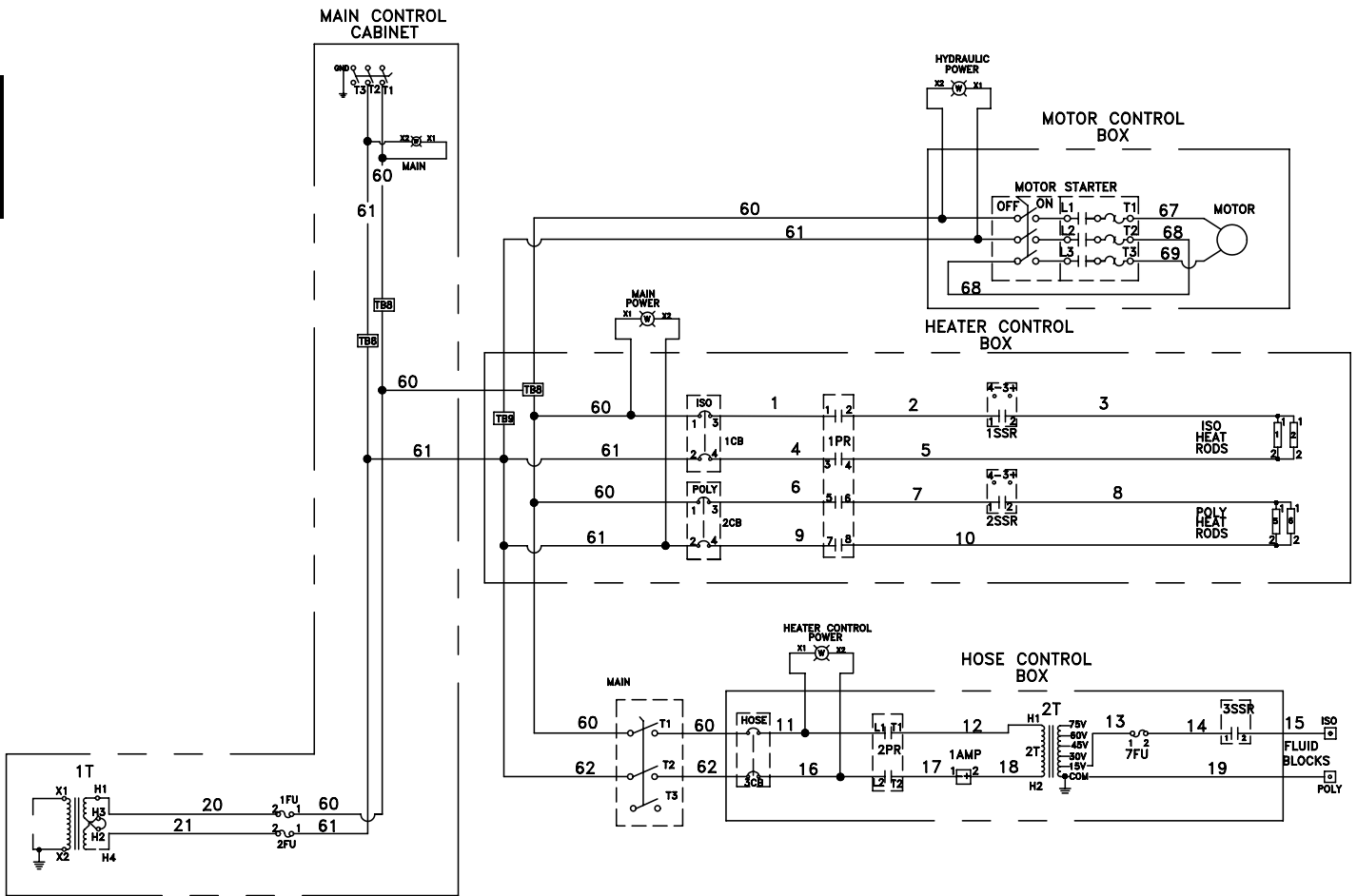

220 VOLT 1 PHASE

# Section 3 - General Information: Sub Assembly Drawings

## 22895-XX Control Box Schematic

Sec. 3:2

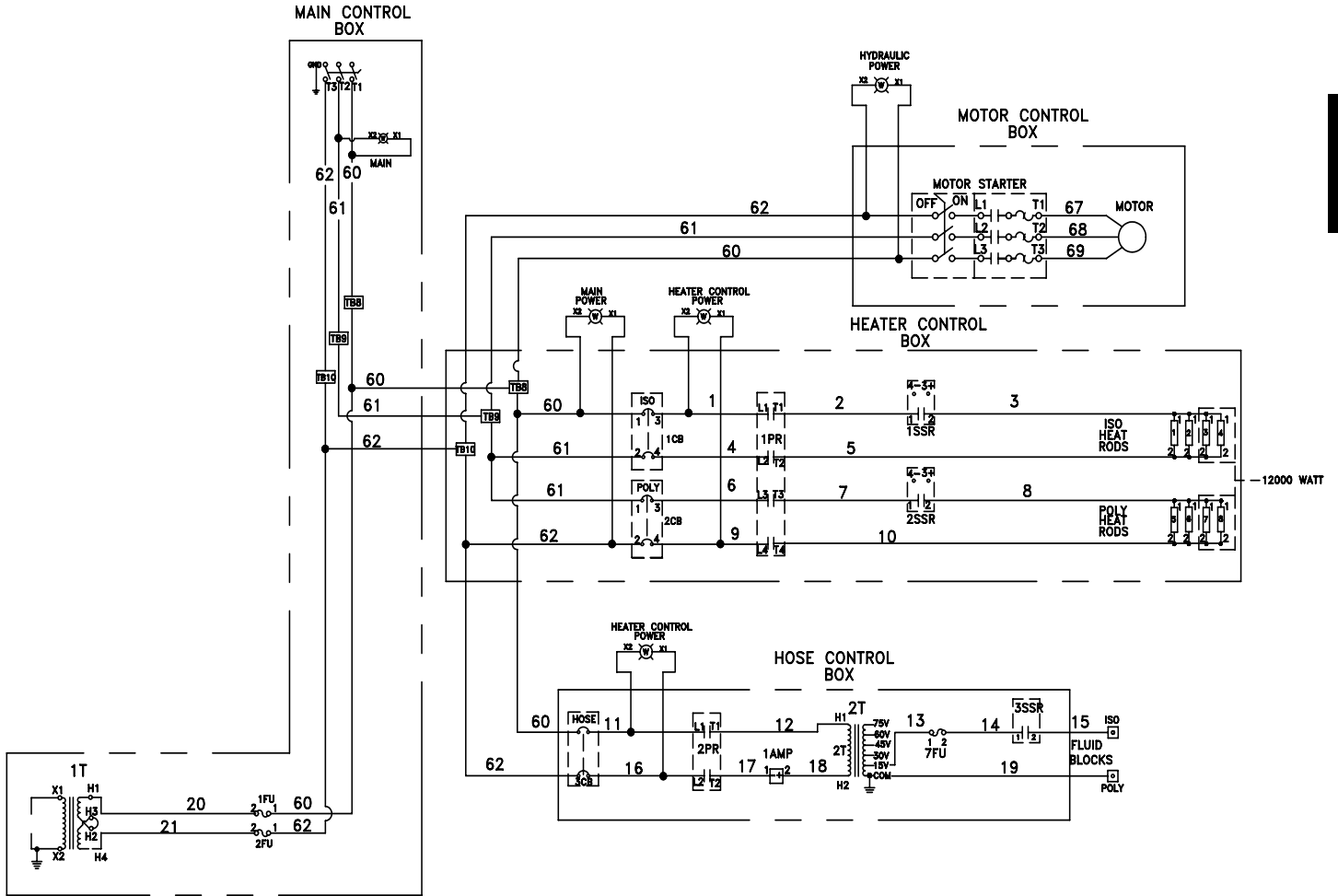

220 VOLT 3 PHASE

## Section 3 - General Information: Sub Assembly Drawings

### 22875-XX Heater Box Assembly

Sec. 3:2

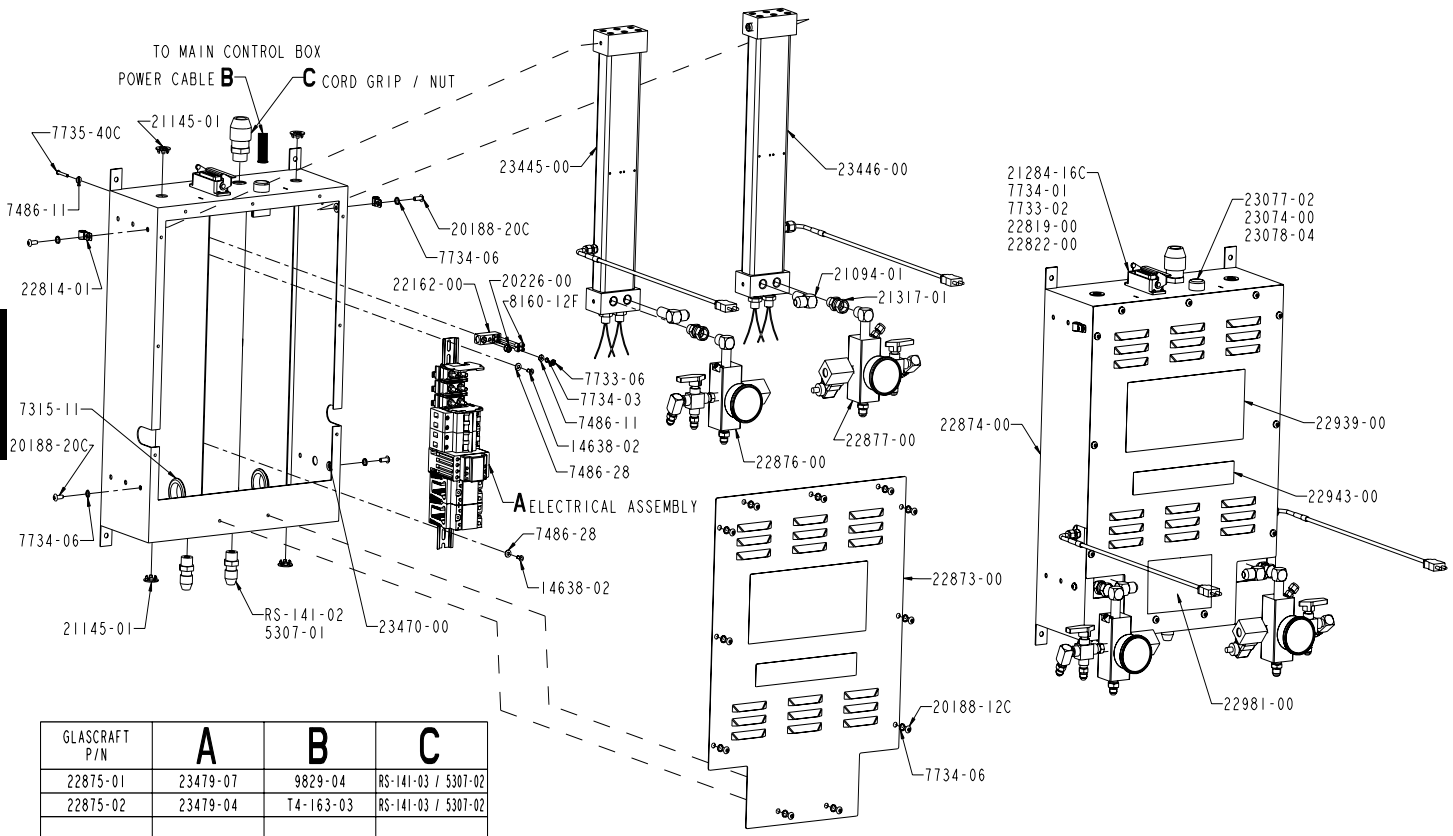

GLASCRAFT P/N	A	B	C
22875-01	23479-07	9829-04	RS-141-03 / 5307-02
22875-02	23479-04	T4-163-03	RS-141-03 / 5307-02

Part Number	Description	Qty.
RS-141-02	CORD GRIP	2
RS-141-03	CORD GRIP	1
14638-02	RIVET	2
17702-00	PILOT LAMP	1
20188-16C	SCREW	11
20188-20C	SCREW	4
20226-00	SET SCREW	1
21094-01	ELBOW FITTING	2
21317-01	FITTING	2
21866-00	COUPLING PLATE	1
21886-00	LAMP MOUNTING BLOCK	1
22150-02	PILOT LIGHT	1
22162-00	CONNECTOR	1
22814-01	LOOP STRAP	2
22819-00	PANEL MOUNT	1
22822-00	TERMINAL CONNECTOR	1

Part Number	Description	Qty.
22873-00	CONTROL BOX COVER	1
22876-00	FLUID MANIFOLD A SIDE	1
22877-00	FLUID MANIFOLD B SIDE	1
23445-00	ISO HEATER	1
23446-00	POLY HEATER	1
23479-04	ELECTRICAL ASSEMBLY	1
5307-01	CONDUIT NUT	2
5307-02	CONDUIT NUT	1
7315-11	RUBBER GROMMET	2
7486-11	WASHER	2
7486-28	WASHER	2
7733-06	HEX NUT	1
7734-03	LOCK WASHER	1
7734-06	LOCK WASHER	15
7735-40C	SCREW	1
8160-12F	SET SCREW	4

## Section 3 - General Information: Sub Assembly Drawings

### 22885-02 Heater Box Assembly

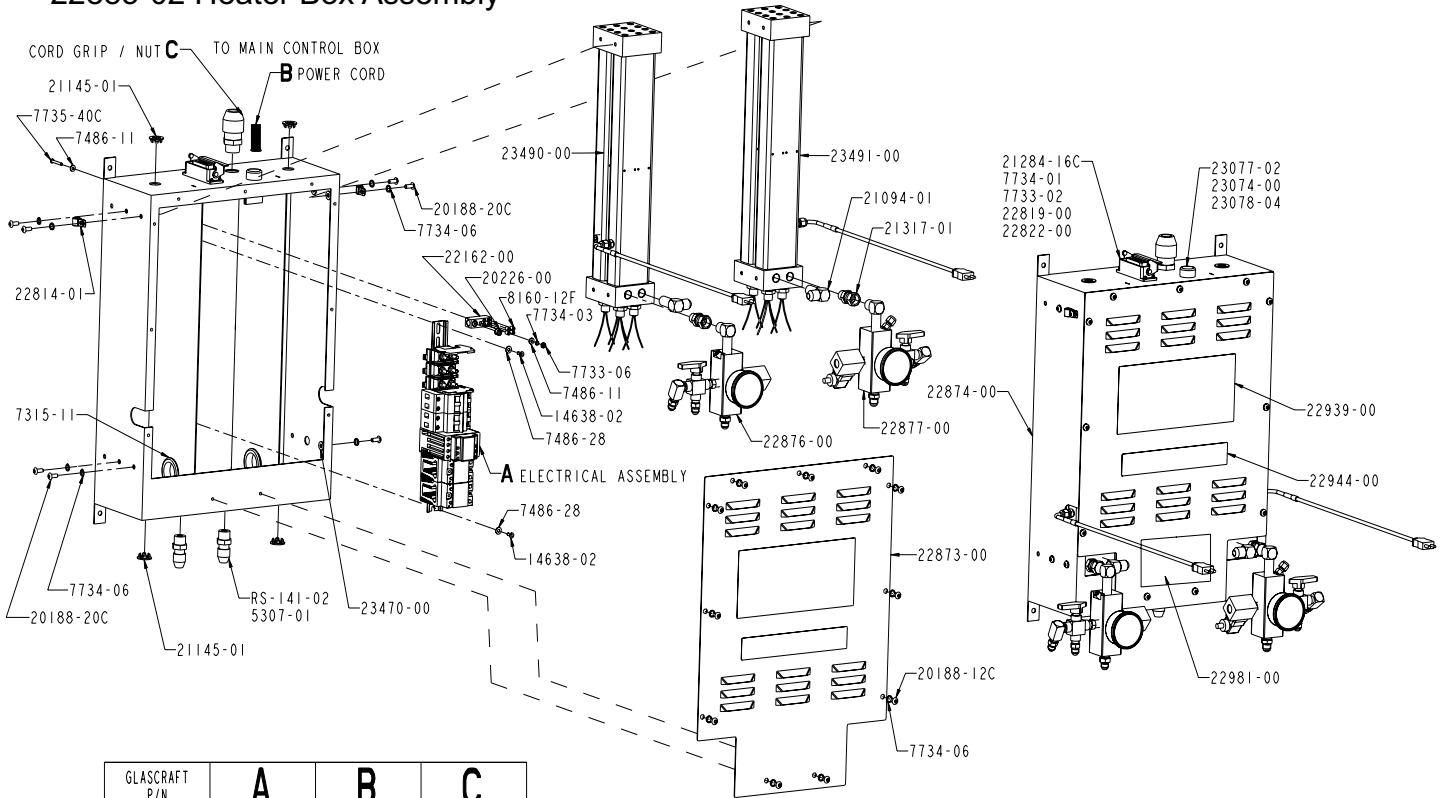

Sec. 3:2

Part Number	Description	Qty.
RS-141-02	CORD GRIP	2
RS-141-03	CORD GRIP	1
14638-02	RIVET	2
17702-00	PILOT LAMP	1
20188-16C	SCREW	11
20188-20C	SCREW	7
20226-00	SET SCREW	1
21094-01	ELBOW FITTING	2
21317-01	FITTING	2
21866-00	COUPLING PLATE	1
21886-00	LAMP MOUNTING BLOCK	1
22150-02	PILOT LIGHT	1
22162-00	CONNECTOR	1
22814-01	LOOP STRAP	2
22819-00	PANEL MOUNT	1
22822-00	TERMINAL CONNECTOR	1
22873-00	CONTROL BOX COVER	1

Part Number	Description	Qty.
22876-00	FLUID MANIFOLD A SIDE	1
22877-00	FLUID MANIFOLD B SIDE	1
22939-00	GUARDIAN MMH DECAL	1
22944-00	MMH 12000 DECAL	1
23479-08	ELECTRICAL ASSEMBLY	1
23490-00	ISO HEATER	1
23491-00	POLY HEATER	1
5307-01	CONDUIT NUT	2
5307-02	CONDUIT NUT	1
7315-11	RUBBER GROMMET	2
7486-11	WASHER	2
7486-28	WASHER	2
7733-06	HEX NUT	1
7734-03	LOCK WASHER	1
7734-06	LOCK WASHER	15
7735-40C	SCREW	1
8160-12F	SET SCREW	4

## Section 3 - General Information: Sub Assembly Drawings

### 22876-00 Fluid Manifold Assembly

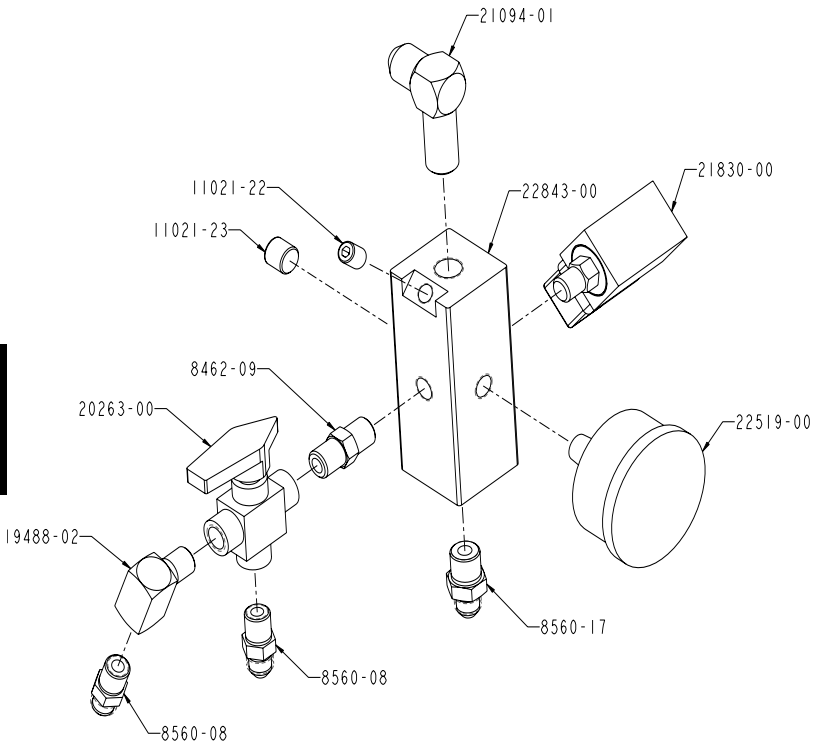

<b>22876-00</b>		
<b>Part Number</b>	<b>Description</b>	<b>Qty.</b>
8462-09	FITTING	1
8560-08	HOSE FITTING	2
8560-17	HOSE FITTING	1
9488-02	ELBOW FITTING	1
11021-22	PIPE PLUG	1
11021-23	PIPE PLUG	1
20263-00	VALVE	1
21094-01	ELBOW FITTING	1
21830-00	OVERPRESSURE SWITCH	1
22519-00	GAUGE	1
22843-00	FLUID MANIFOLD	1

**REVISION A**

### 22877-00 Fluid Manifold Assembly

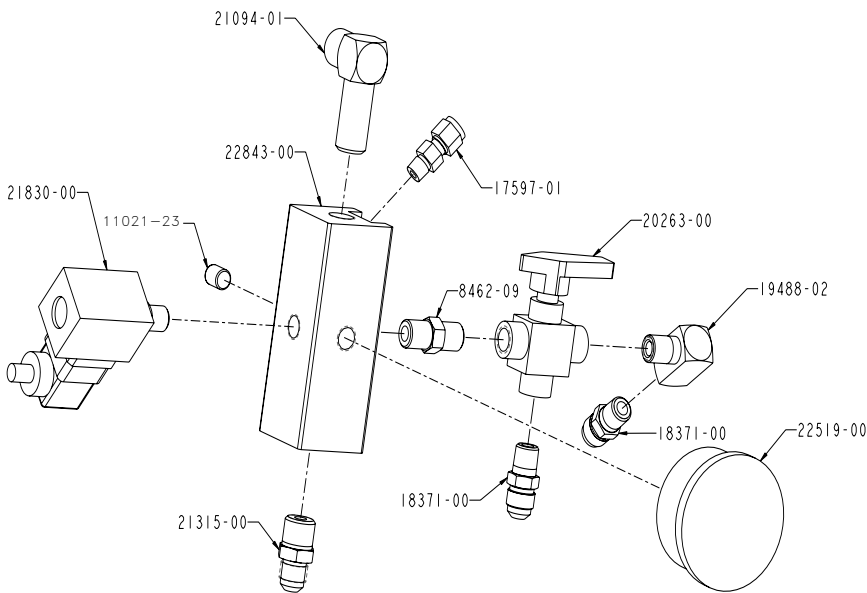

<b>22877-00</b>		
<b>Part Number</b>	<b>Description</b>	<b>Qty.</b>
8462-09	FITTING	1
17597-01	FITTING	1
18371-00	HOSE FITTING	2
11021-23	PIPE PLUG	1
19488-02	ELBOW FITTING	1
20263-00	VALVE	1
21094-01	ELBOW FITTING	1
21315-00	HOSE FITTING	1
21830-00	OVERPRESSURE SWITCH	1
22519-00	GAUGE	1
22843-00	FLUID MANIFOLD	1



## Section 3 - General Information: Sub Assembly Drawings

### ISO / POLY Heater Assembly

GLASCRAFT P/N	A	WATTS	QTY.
23445-00	22019-00	1500	2
23445-02	22019-02	750	2

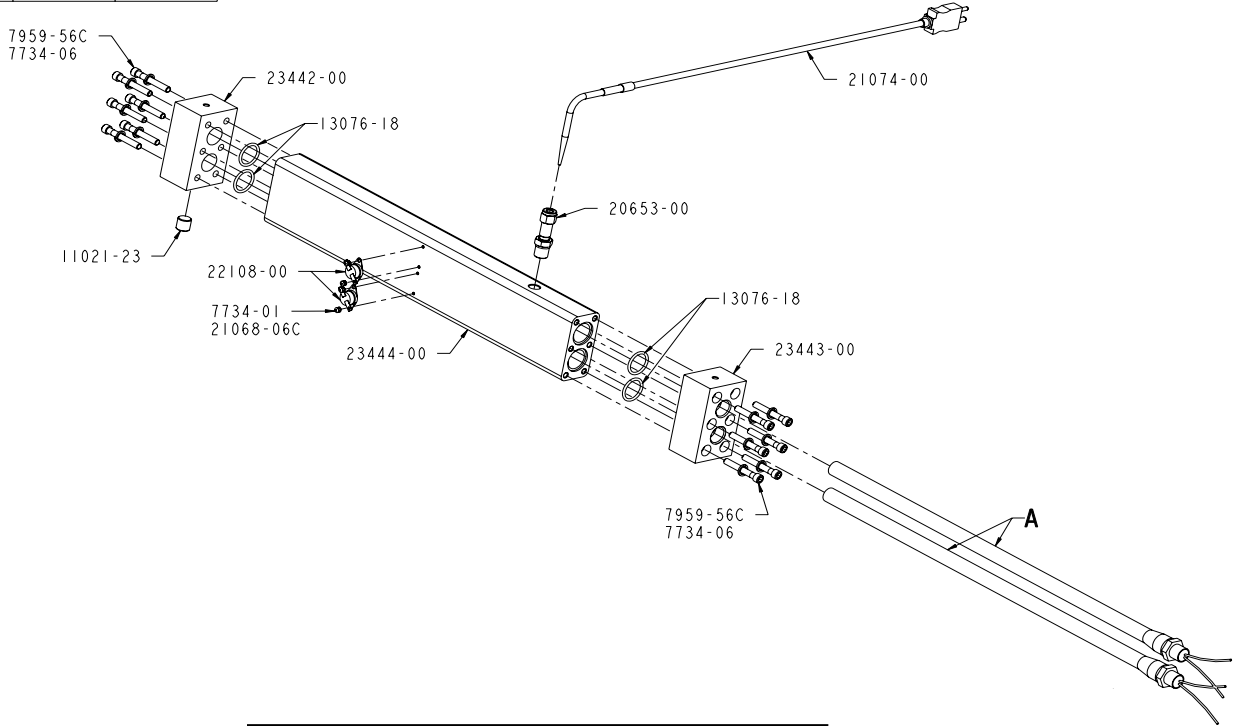

Sec. 3:2

23445-00 / 23446-00		
Part Number	Description	Qty.
11021-23	PLUG	1
13076-18	O-RING	4
20653-00	FITTING	1
21068-06C	SCREW	4
21074-00	THERMOCOUPLE	1
22108-00	OVERTEMP SWITCH	2
23442-00	HEATER FRONT CAP	1
23443-00	HEATER REAR CAP	1
23444-00	HEATER BODY	1
23483-01	ELECTRIC PLUG	2
23484-01	ELECTRIC PLUG	2
23486-01	ELECTRIC PLUG	2
23487-01	ELECTRIC PLUG	2
7734-01	LOCK WASHER	4
7734-06	LOCK WASHER	12
7959-56C	SCREW	12

(6000 WATTS)

## Section 3 - General Information: Sub Assembly Drawings

### ISO / POLY Heater Assembly

Sec. 3:2

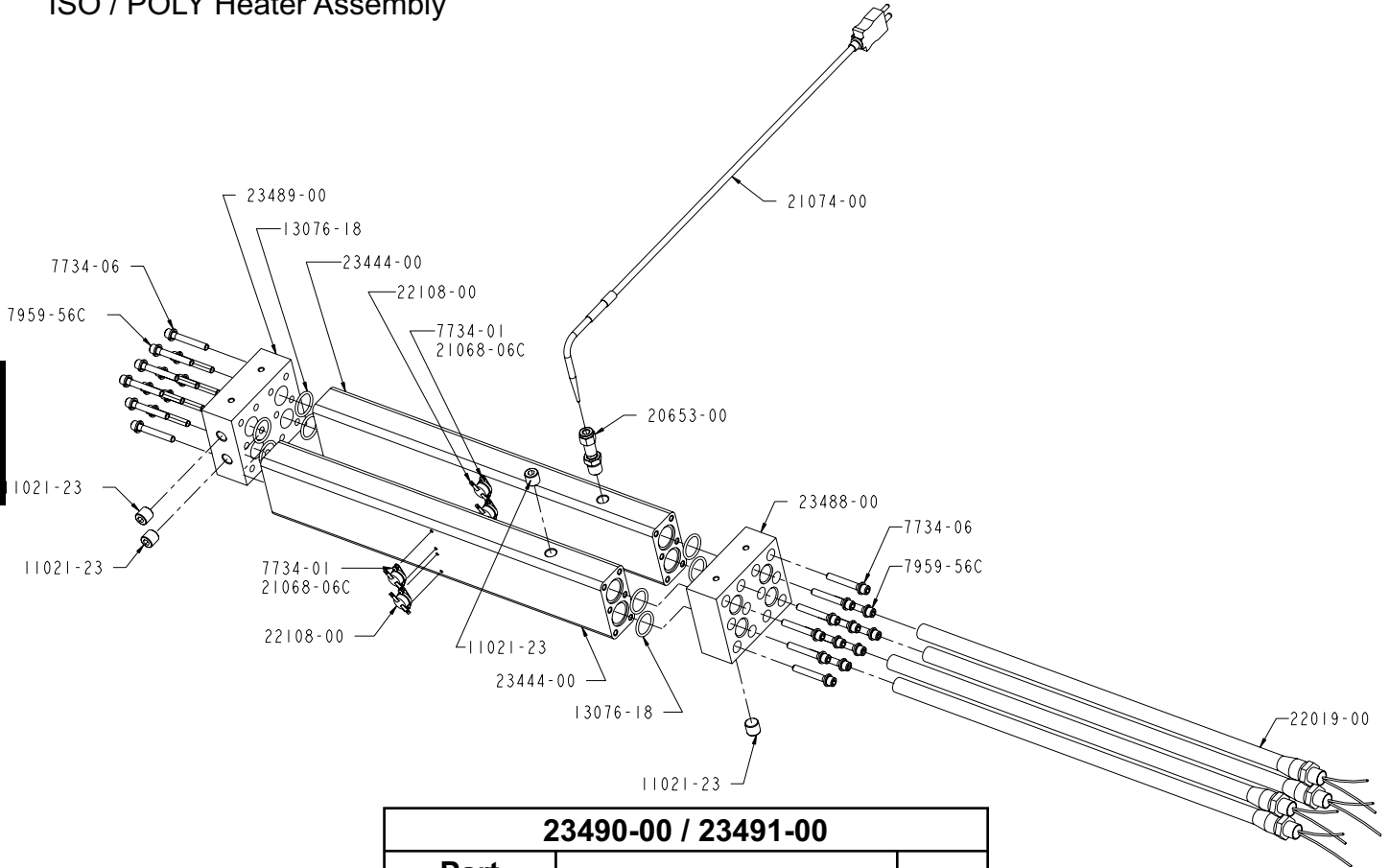

<b>23490-00 / 23491-00</b>		
Part Number	Description	Qty.
11021-23	PIPE PLUG	4
13076-18	O-RING	8
20653-00	FITTING	1
21068-06C	SCREW	8
21074-00	THERMOCOUPLE	1
22019-00	HEATER ELEMENT	4
22108-00	OVERTEMP SWITCH	4
23444-00	HEATER BODY	2
23483-01	FEMALE ELECTRICAL PLUG	1
23484-01	MALE ELECTRICAL PLUG	1
23486-01	FEMALE ELECTRICAL PLUG	1
23487-01	MALE ELECTRICAL	1
23488-00	HEATER TOP CAP	1
23489-00	HEATER BOTTOM CAP	1
7734-01	LOCK WASHER	8
7734-06	LOCK WASHER	24
7959-56C	SCREW	24

(12000 WATTS)

# Section 3 - General Information: Sub Assembly Drawings

## 22290-01 Portable Transformer Assembly

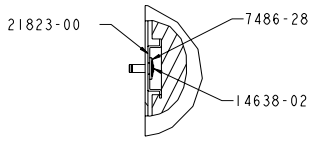

DETAIL **C**  
SCALE 1.000

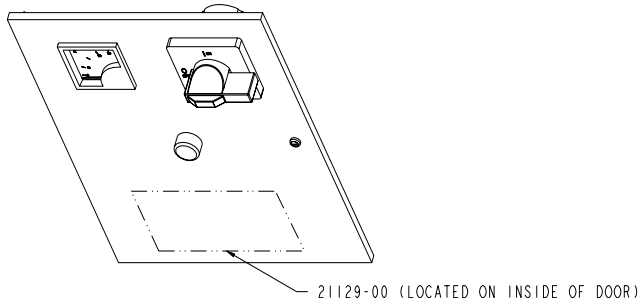
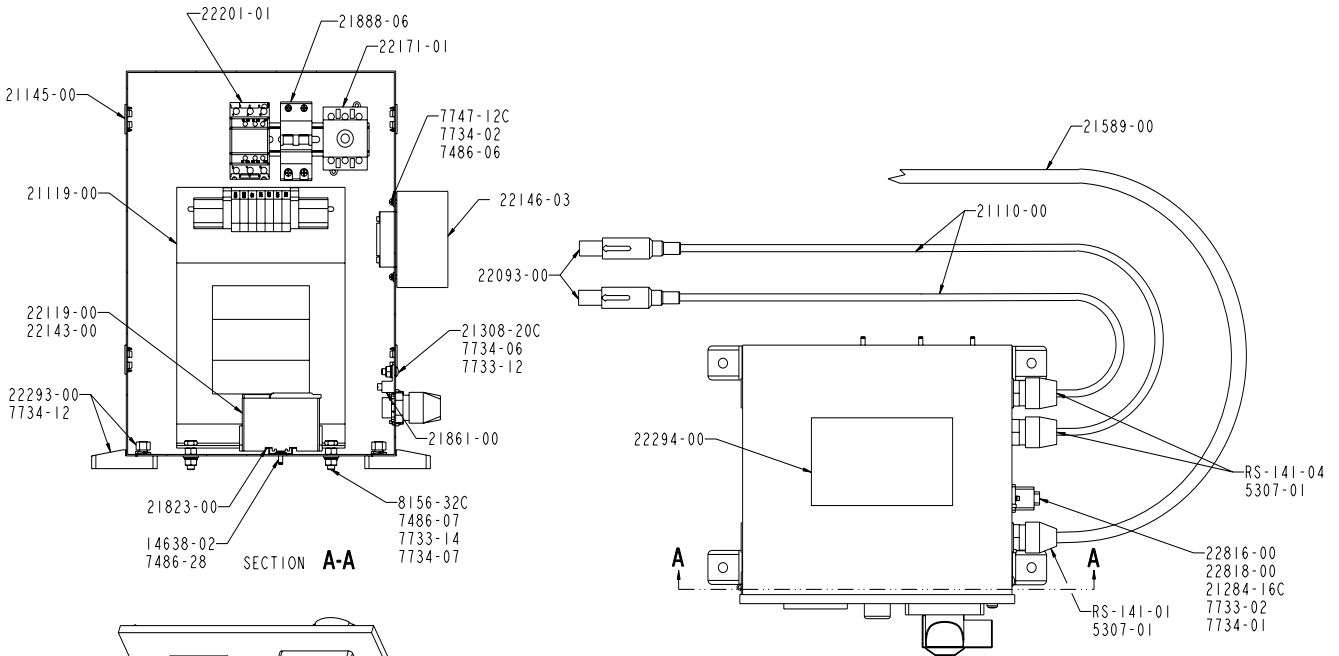
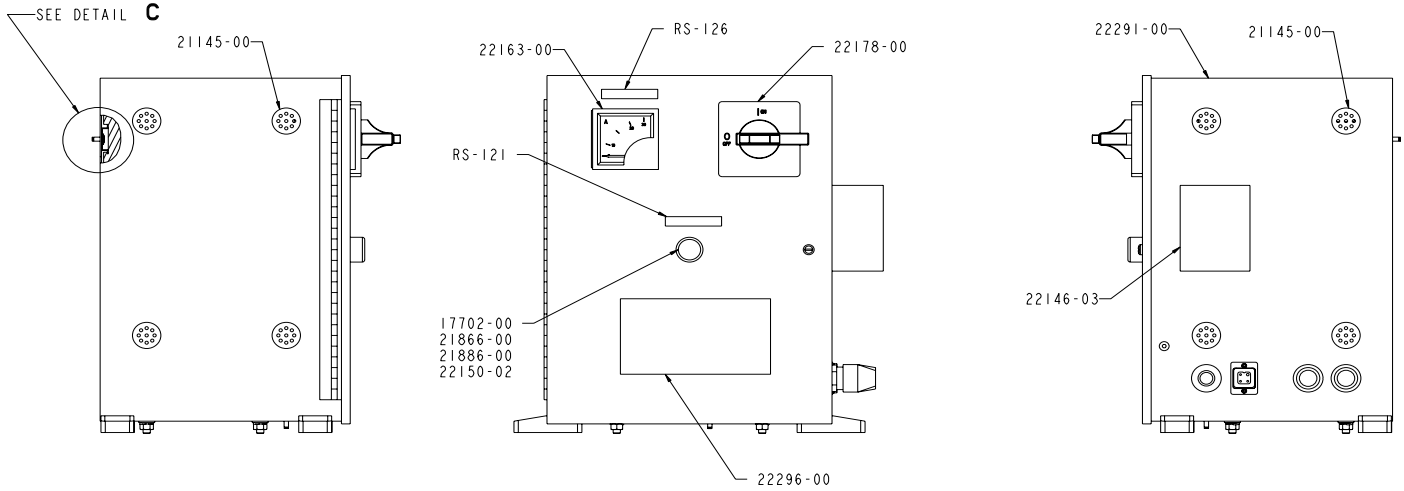

Sec. 3:2

## Section 3 - General Information: Sub Assembly Drawings

### 22290-01 Portable Transformer Parts List

Part Number	Description	Qty.
RS-121	HOSE DECAL	1
RS-126	HOSE CURRENT DECAL	1
RS-141-01	CORD GRIP	1
RS-141-04	CORD GRIP	2
13424-01	CABLE TIE	5
14638-02	RIVET	5
17702-00	PILOT LAMP	1
21119-00	TRANSFORMER	1
21129-00	TRANSFORMER DECAL	1
21145-00	VENT PLUG	8
21284-16C	SCREW	2
21308-20C	SCREW	1
21598-00	TRANSFER HOUSING SEAT	12
21823-00	DIN RAIL	0.8 Ft.
21861-00	CONDUCTOR CONNECTOR	1
21866-00	COUPLING PLATE	1
21886-00	LAMP MOUNTING BLOCK	1
21888-06	CIRCUIT BREAKER	1
21953-64	SELF-TAP SCREW	4
22088-05	ELECTRIC PLUG	2
22119-00	FUSE BLOCK	1
22143-00	FUSE	1
22146-03	SOLID STATE RELAY	1

Part Number	Description	Qty.
22150-02	PILOT LIGHT	1
22163-00	AMMETER	1
22171-01	SWITCH BLOCK	1
22178-00	POWER SWITCH	1
22201-01	MECHANICAL CONTACTOR	1
22291-00	TRANSFORMER BOX	1
22293-00	TRANSFORMER FEET BOX	4
22294-00	CAUTION DECAL	1
22296-00	TRANSFORMER DECAL	1
22816-00	PANEL MOUNT HOUSING	1
22818-00	FEMALE INSERT CONNECTOR	1
5307-01	CONDUIT NUT	3
7486-06	WASHER	4
7486-07	WASHER	4
7486-28	WASHER	5
7733-02	HEX NUT	2
7733-12	HEX NUT	1
7733-14	HEX NUT	8
7734-01	LOCK WASHER	2
7734-02	LOCK WASHER	4
7734-06	LOCK WASHER	1
7734-07	LOCK WASHER	4
7734-12	LOCK WASHER	4
7747-12C	SCREW	4
8156-32C	SCREW	4

Sec. 3:2

## Section 3 - General Information: Sub Assembly Drawings

### 19524-01 Medium Pressure Hose Assembly

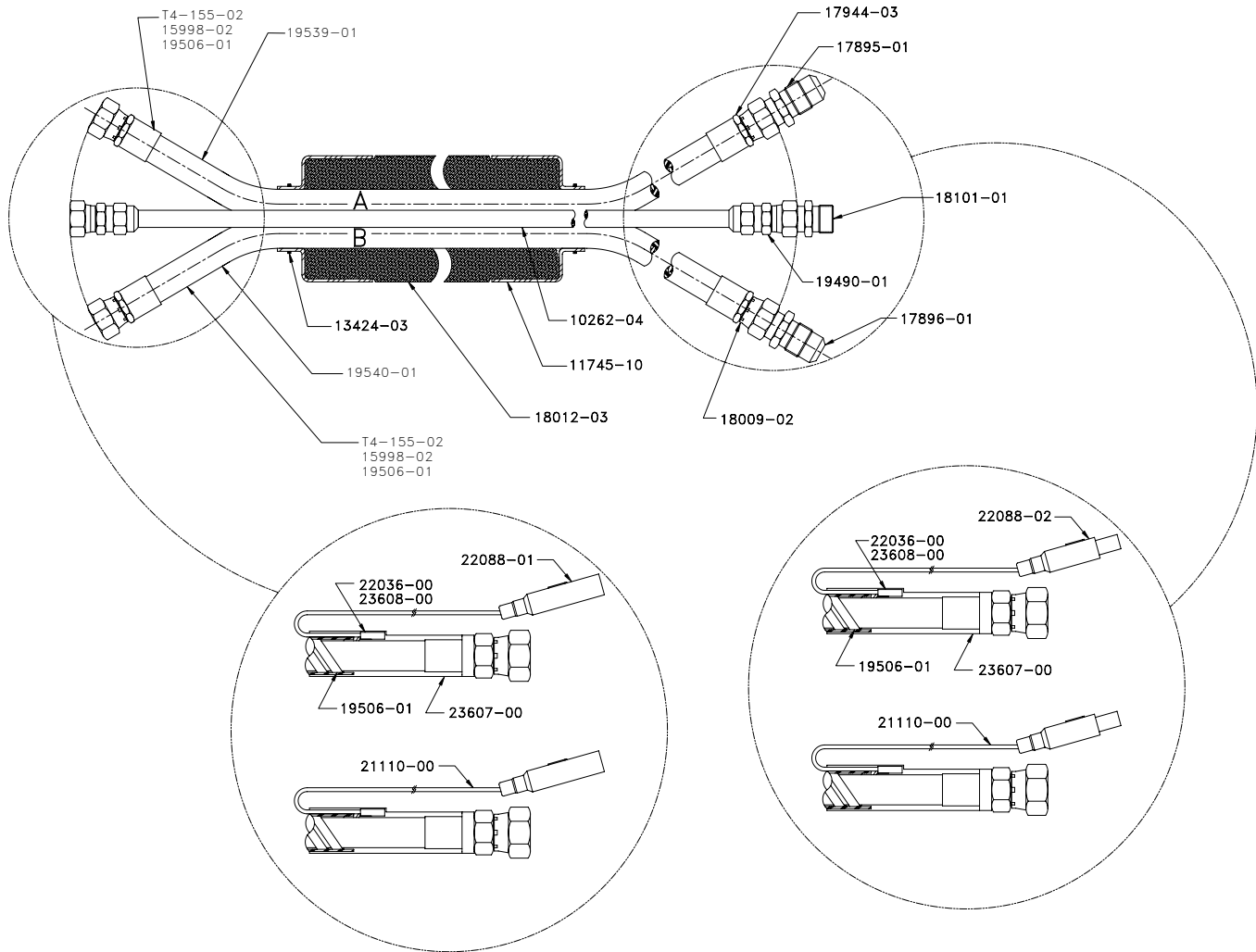

Sec. 3:2

Part Number	Description	Qty.
T4-155-02	MATERIAL HOSE	100 ft.
10262-04	NYLON FLUID HOSE	50 ft.
11745-10	HEAT SHRINK TUBING SHRINK	1 ft.
13424-03	CABLE TIE	4
13424-05	CABLE TIE	1
15998-02	NEOPRENE TUBING	100 ft.
17895-01	UNION FITTING	1
17896-01	UNION TUBE FITTING	1
17944-03	HOSE FITTING	2
18009-02	HOSE FITTING	2
18012-03	HEATED HOSE COVER	50 ft.
18101-01	ADAPTER FITTING	1
19490-01	HOSE FITTING	2

Part Number	Description	Qty.
19506-01	COPPER STRIP	6 lbs.
22036-00	HEAT TAPE END SEAL	4
22088-01	MALE ELECTRIC PLUG ASSEMBLY	2
22088-02	FEMALE ELECTRIC PLUG ASSEMBLY	2
23607-00	COLD SPLICE KIT	4
23608-00	SPLICE CONNECTOR	4

## Section 3 - General Information: Maintenance

### Fluid Sections

Each week:

1. Wipe any residue from the mouth of the lubrication cup and add 1 teaspoon of a suitable lubricating solution to the "POLY" side pump.

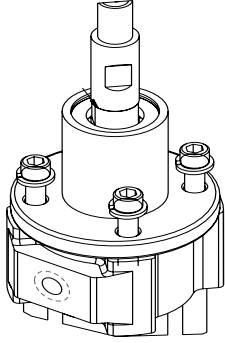

Each month:

1. Change the lubricating solution in the ISO bottle.

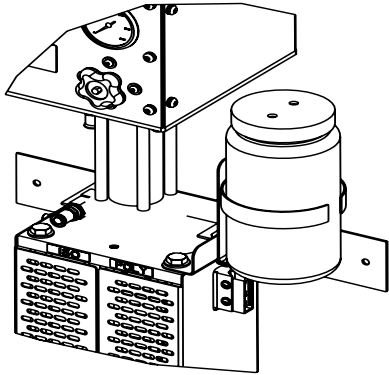

## Section 3 - General Information: Troubleshooting

### Over Pressure System Protection

The system incorporates monitors for high pressure monitoring. These monitoring devices will prevent the system from continued operation if high pressure situations develop.

There are pressure sensors located on each side of the hose mounting block. The high pressure sensor is located at the outbound of the fluid section.

The high pressure monitoring sensor will engage if fluid pressure increases above 3200 psi.

If a high pressure situation develops, the sensor will detect this and immediately engage the hold-in circuit.

This will disengage power to the machine and it will stop cycling. It will also turn the heater off.

On the control box panel, there are two yellow lighted push buttons marked over pressure. One of these push buttons will be illuminated after the monitoring sensor engages, indicating where the problem is located (ISO or Poly).

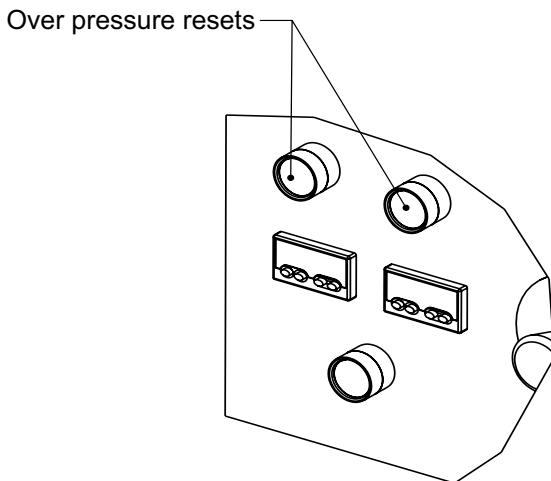

In an over pressure situation, the system will remain shut down until it is manually reset.

At this point, it is necessary to determine if the problem is an over pressure situation.

When the sensor engages, the system will be frozen, giving you the pressure readings at the time the problem was detected.

Inspect the fluid pressure gauges, in an over pressure situation, one of the fluid pressure gauges will be significantly higher than the other gauge.



*When main power to unit is on, the console will have wires that are live. Disconnect or turn off main power source before opening console to make any repairs.*



*Before performing any repairs on the system, ALL AIR and FLUID PRESSURES SHOULD BE RELIEVED TO ZERO (BLEED-OFF)!*

### Over Pressure Problem Correction

1. Determine if the problem is high pressure related.
2. Relieve system hydraulic pressure.
3. Turn off main power
4. Fix the problem area:
  - a. Potential high pressure causes:
    - Restriction
    - Overheating material in static position
    - ISO filter at gun
5. Re-start system for operation
6. Once the power has been turned off and problem solved and the main power is turned on again, the over over pressure lighted buttons will automatically be reset.



*For additional diagnostics refer to trouble shooting guide GC-1380*



*If you do not understand the electrical hook-up described above, consult your local GlasCraft distributor or a qualified electrician. It is recommended that a qualified, licensed electrician should install power to the supply disconnect. You should always follow all local or national electrical codes.*



*Disconnect power source BEFORE attempting any repairs or opening the Control Boxes. Access to internal parts is limited to qualified personnel ONLY! Place the main power breaker in the OFF position BEFORE disconnecting the power cables. This equipment is not approved for use in hazardous locations as set forth in the National Electrical Code Article 500 and Sub-Part "S" of the OSHA Standards.*

## Section 3 - General Information: Options

### 22940-00 Stick Transfer Pump Assembly

Sec. 3:5

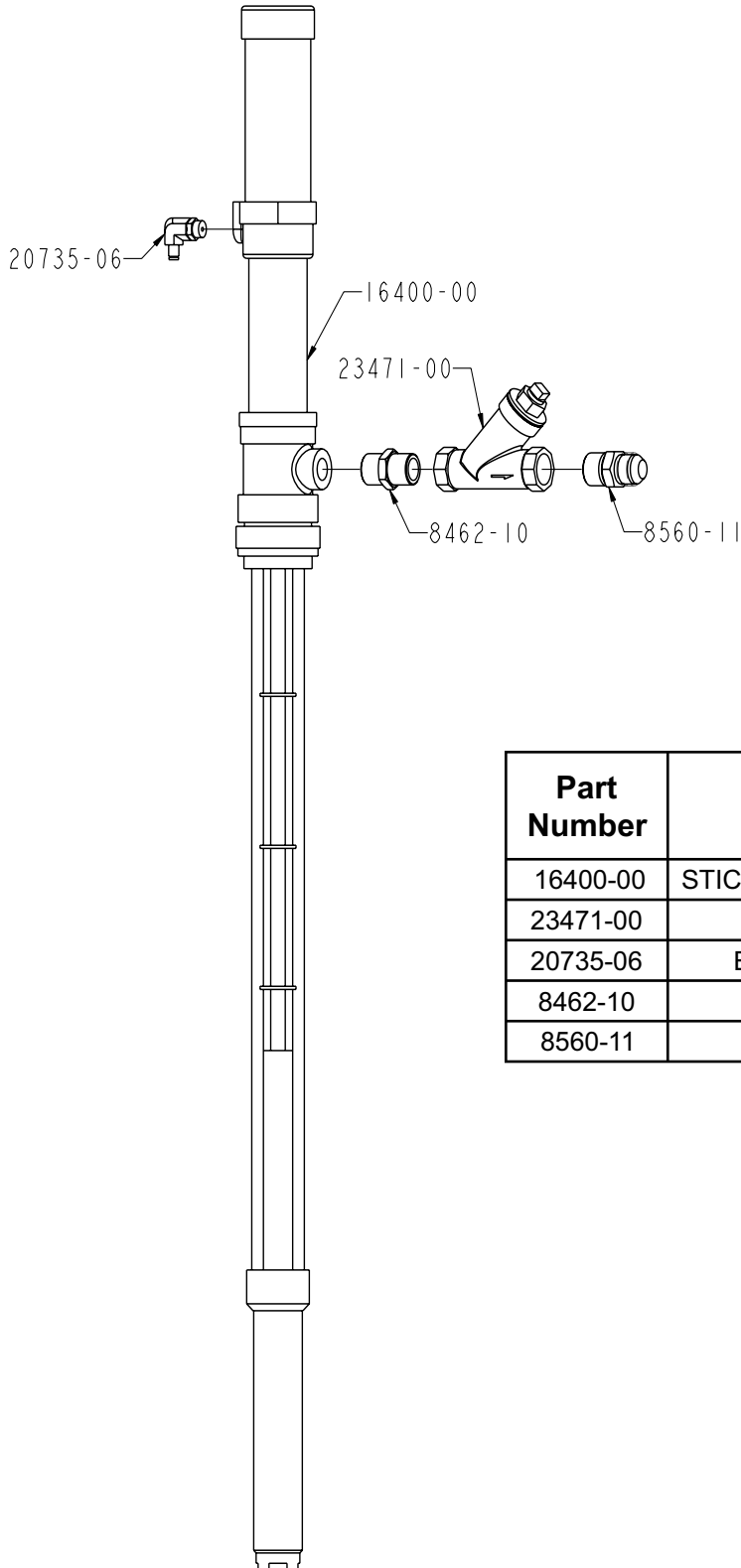

Part Number	Description	Qty.
16400-00	STICK TRANSFER PUMP	1
23471-00	FILTER	1
20735-06	ELBOW FITTING	1
8462-10	FITTING	1
8560-11	FITTING	1

**Note:** The transfer assemblies are the same way for both ISO & POLY side. Use teflon tape on NPT threads.



## Section 3 - General Information: Options

### 23416-00 Transfer Pump Kit

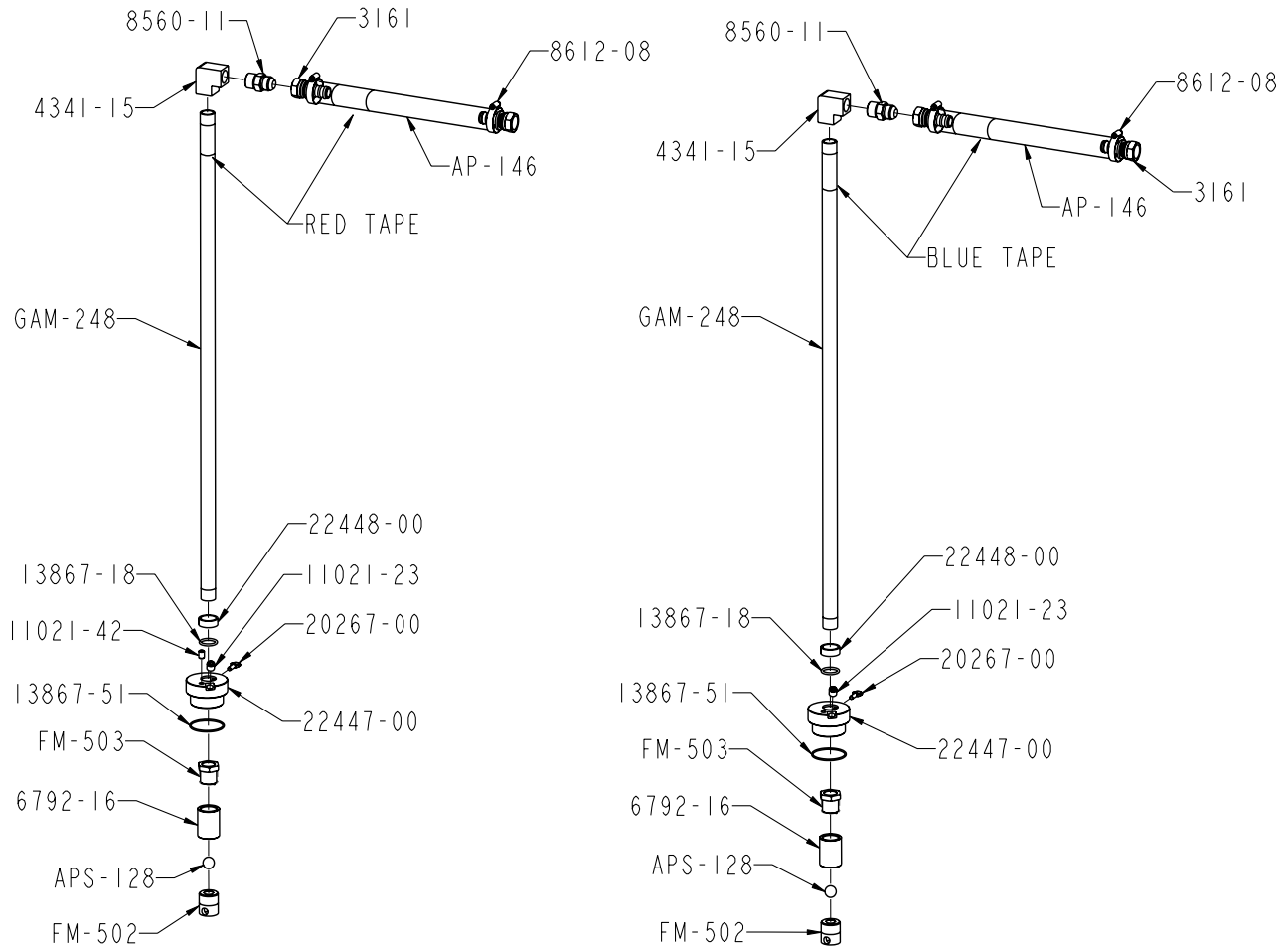

Sec. 3:5

Part Number	Description	Qty.
AP-146	MATERIAL TRANSFER HOSE	8 FT.
APS-128	CHROME BALL	2
FM-502	FOOT VALVE	2
FM-503	FOOT VALVE BALL RETAINER	2
GAM-248	PICK-UP TUBE	2
11021-23	PIPE PLUG	2
11021-42	PIPE PLUG	1
13867-18	O-RING	2
13867-51	O-RING	2
20267-00	THUMB SCREW	2
22447-00	BUNG ADAPTER	2

Part Number	Description	Qty.
3161	FITTING	4
4341-15	ELBOW FITTING	2
6792-16	FITTING	2
8560-11	FITTING	2
8612-08	HOSE CLAMP	4

## Section 3 - General Information: Options

### 22887-00 Diaphragm Transfer Pump Assembly

Sec. 3:5

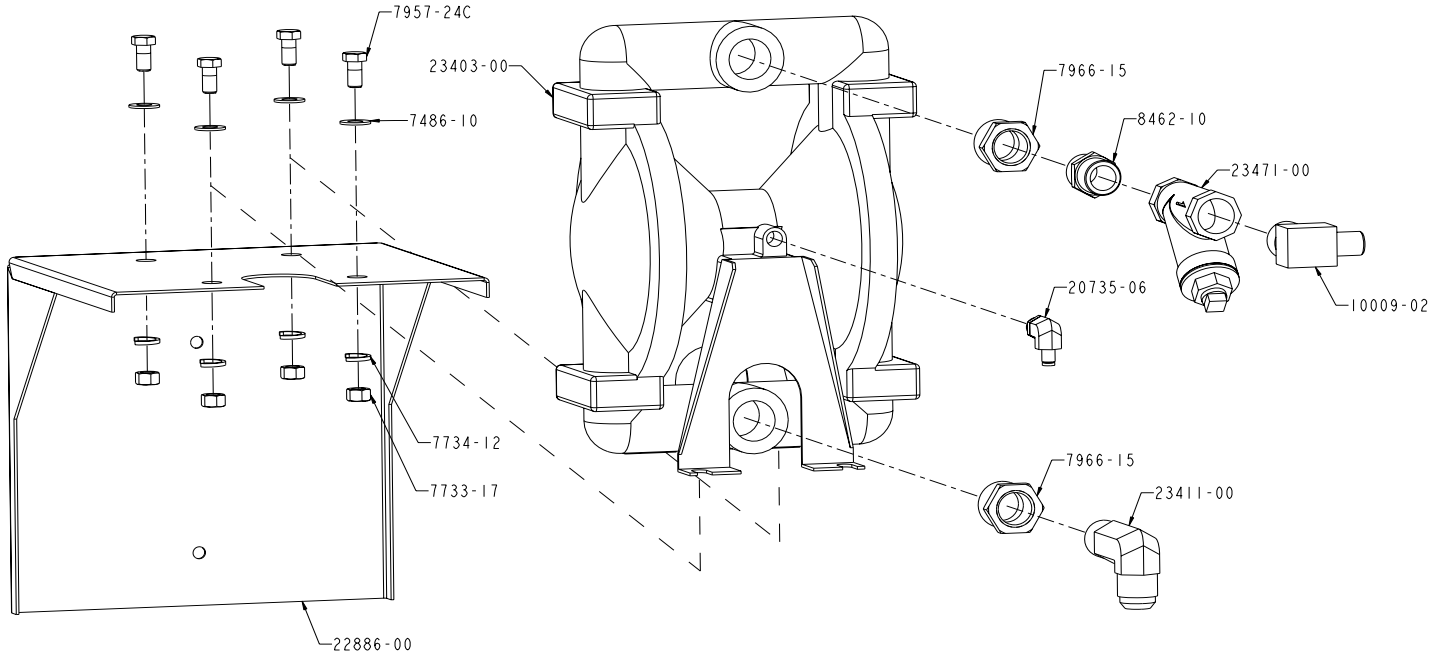

Part Number	Description	Qty.
10009-12	ELBOW FITTING	1
10009-02	ELBOW FITTING	1
23471-00	FLUID FILTER	1
20735-06	ELBOW FITTING	1
22886-00	PUMP MOUNTING BRACKET	1
23403-00	DIAPHRAGM PUMP	1
23411-00	ELBOW FITTING	1
7486-10	WASHER	4
7733-17	HEX NUT	4
7734-12	LOCK WASHER	4
7957-24C	SCREW	4
7966-15	FITTING	2
8462-10	FITTING	1

**Note:** The transfer assemblies are the same way for both ISO & POLY side. Use teflon tape on NPT threads.

## Section 3 - General Information: Options

22836-01 Twin Hose Clamp 1in.

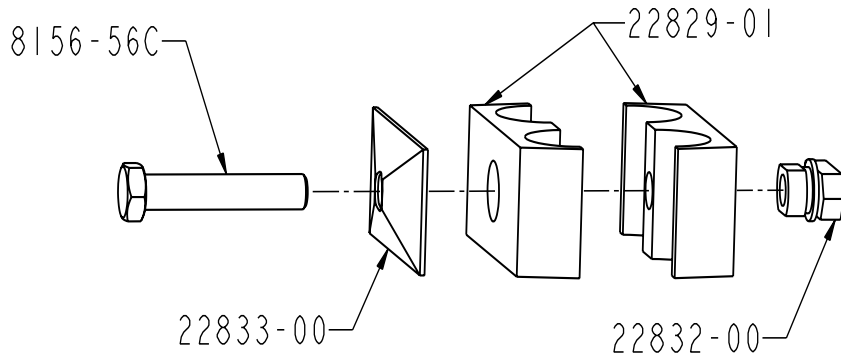

Part Number	Description	Qty.
22829-01	HOSE CLAMP	1
22832-00	RAIL MOUNTING NUT	1
22833-00	COVER PLATE	1
8156-56C	SCREW	1

**REVISION A**

22836-02 Twin Double Stack Hose Clamp 1in. - 1/2in.

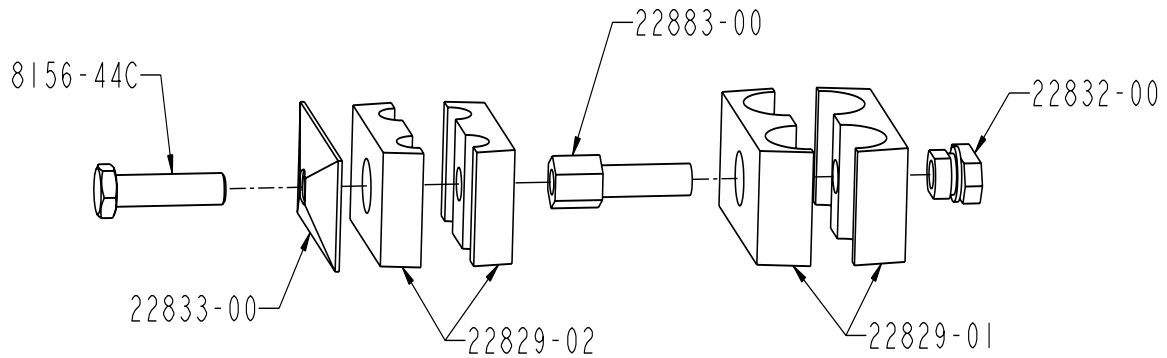

Part Number	Description	Qty.
22829-01	TWIN HOSE CLAMP	1
22829-02	TWIN HOSE CLAMP	1
22832-00	RAIL MOUNTING NUT	1
22833-00	COVER PLATE	1

Part Number	Description	Qty.
22883-00	STACKING BOLT	1
8156-44C	SCREW	1

**REVISION A**

## Section 3 - General Information: Options

22835-01 Standard Hose Clamp 1/4in. Dia.

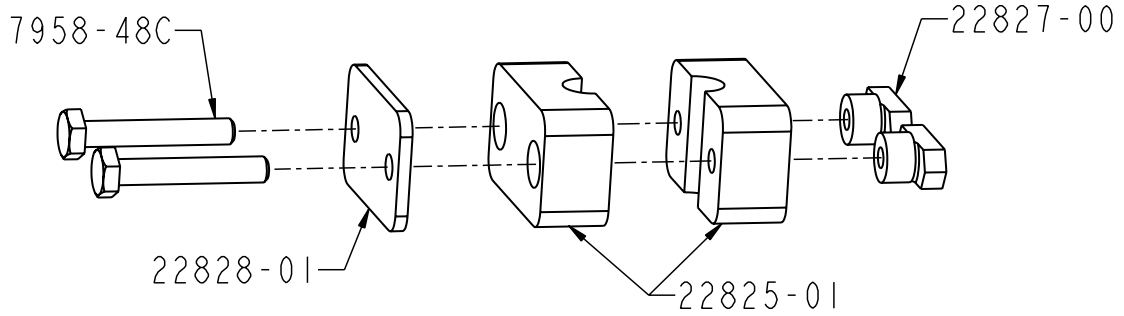

Part Number	Description	Qty.
22825-01	HOSE CLAMP	1
22827-00	RAIL MOUNTING NUT	2
22828-01	COVER PLATE	1
7958-48C	SCREW	2

**REVISION A**

22835-02 Standard Hose Clamp 2in. Dia.

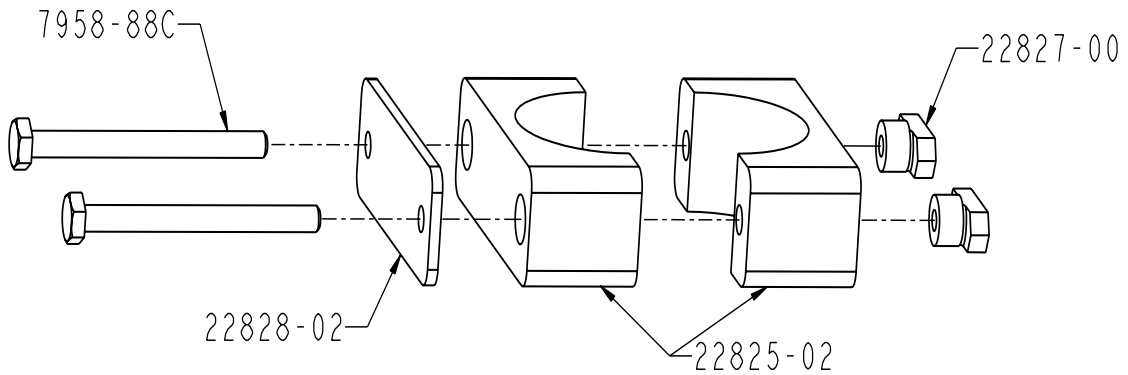

Part Number	Description	Qty.
22825-02	HOSE CLAMP	1
22827-00	RAIL MOUNTING NUT	2
22828-02	COVER PLATE	1
7958-88C	SCREW	2

**REVISION A**

## Section 3 - General Information: Options

GlasCraft recommends that the following holes be drilled in the optional wire-way.

NOTE: The overall length of the wire-way = 88 in.

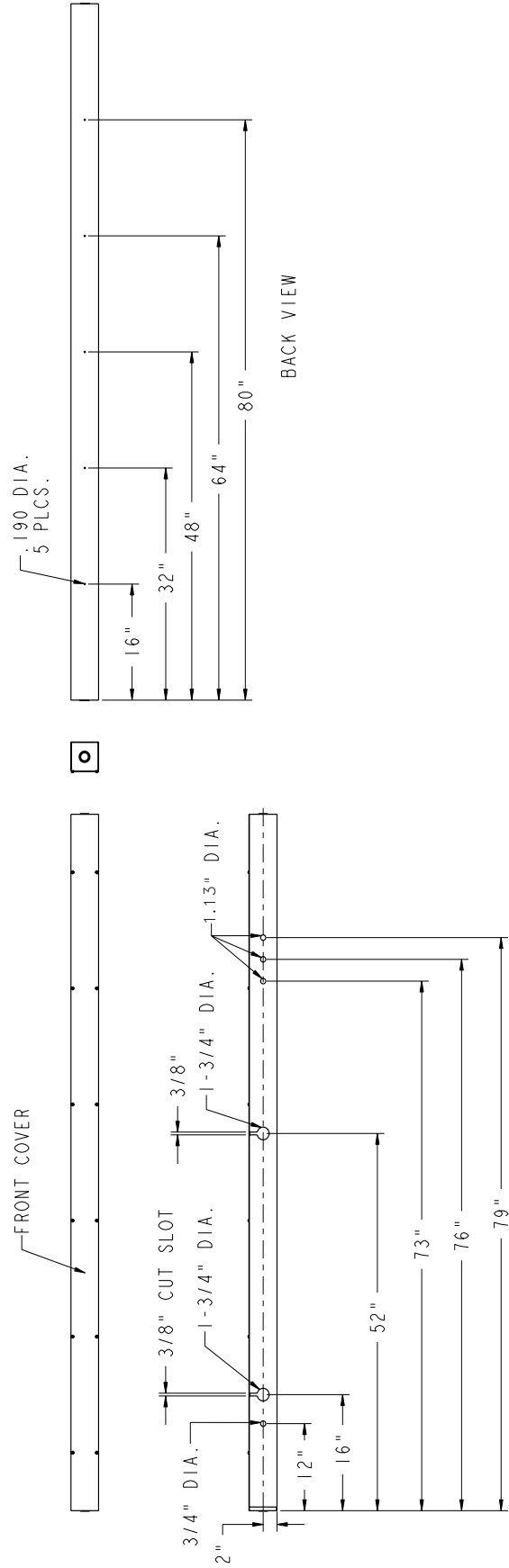
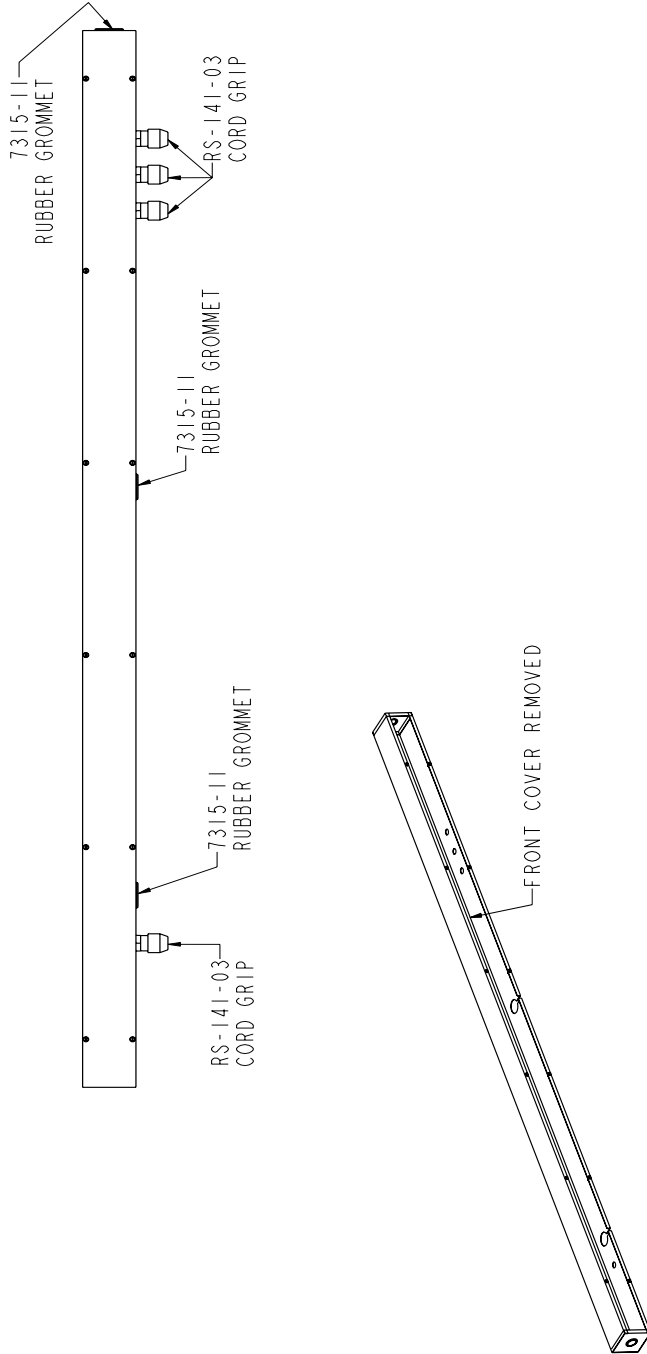

## Section 4 - Safety Information: General Safety

### Safe Handling And Use Of Urethane Foam Equipment

#### Introduction

Any tool, if used improperly, can be dangerous. Safety is ultimately the responsibility of those using the tool. In like manner, safe operation of polyester processes is the responsibility of those who use such processes and those who operate the equipment. This manual outlines procedures to be followed in conducting polyester operations safely.

All personnel involved in dispensing operations should read and understand this manual. It is most important that equipment operators, maintenance, and supervisory personnel understand the requirements for safe operation.

This manual cannot answer every circumstance; each user should examine his own operation, develop his own safety program and be assured that his equipment operators follow correct procedures. GlasCraft hopes that this manual is helpful to the user and recommends that the precautions in this manual be included in any such program.

Urethane foam systems are comprised of several different chemical compounds, some of which may be hazardous if improperly used.



*Particular caution must be taken with respect to the vapors released during the use of urethane foam systems.*

Isocyanate compounds are used in urethane foaming operations. The medical history of persons who may be exposed to such isocyanates should be examined. It is recommended that individuals with a history of chronic respiratory ailments should avoid exposure to all isocyanates.

In addition to the manual, GlasCraft recommends that the user consult the regulations established under the Occupational Safety & Health Act (OSHA), particularly the following sections:

- 1910.94 Pertaining to ventilation.
- 1910.106 Pertaining to flammable liquids.
- 1910.107 Pertaining to spray finishing operations, particularly Paragraph (m)

Organic Peroxides and Dual Component Coatings. Local codes and authorities also have standards to be followed in the operation of your spraying equipment. Chemical manufacturer's recommendations should be obtained and considered. Your insurance carrier will be helpful in answering questions that arise in your development of safe procedures.

#### Personnel Safety Equipment

GlasCraft recommends the following Personal Safety Equipment for conducting safe operations of the Polyester Systems:



EYE PROTECTION



HEARING PROTECTION



BREATHING PROTECTION

GlasCraft recommends that the user consult the state and local regulations established for all Safety equipment listed.

#### Operating Safely

In operating urethane foam equipment safely, user should make every effort to:

1. Handle chemicals safely.
2. Provide adequate ventilation.
3. Provide adequate safety equipment (gloves, respirators, safety glasses, protective clothing, etc.) for operators and all others working in areas where they may be exposed to the chemicals or their vapors.
4. Avoid operating equipment which has given any indication of malfunction.
5. Become fully acquainted with the equipment and chemicals used.

#### Handling Chemicals Safely

Storage of polyisocyanates, diamines, and organic solvents should be isolated and restricted to specially constructed storage rooms. Store chemicals in original containers and according to manufacturer's recommendations listed on the container. Maximum ambient temperatures to which such chemicals should be exposed are specified by the manufacturer and MUST NOT be exceeded either in the storage area or in the spraying or pouring area.

## Section 4 - Safety Information: General Safety

To avoid moisture contamination, don't open containers until ready for use. After use, the remaining material should be re-sealed in the original container and stored in areas away from moisture.

During clean-up of spilled isocyanate component, respirators, gloves and eye protection must be worn. Isocyanates which have been spilled can be controlled by covering them with dry sawdust and/or other absorbent, inert materials. Care should be taken to avoid skin contact. The absorbent material and the absorbed isocyanate should be collected promptly, placed in an open-top container, and treated with dilute solutions of ammonium hydroxide and/or alcohol. While being treated in this manner, the material should be in an adequately ventilated area. Clothing on which any material has been spilled should be removed immediately, and cleaned before being worn again.

### Clean-Up Solvents

#### WARNING

*A hazardous situation may be present in your pressurized fluid system!*

*Halogenated Hydrocarbon Solvents can cause an explosion when used with aluminum or galvanized components in a closed (pressurized) fluid system (pumps, heaters, filters, valves, spray guns, tanks, etc.).*

*The explosion could cause serious injury, death and/or substantial property damage.*

*Cleaning agents, coatings, paints, etc. may contain Halogenated Hydrocarbon Solvents.*

*Some GlasCraft spray equipment includes aluminum or galvanized components and will be affected by Halogenated Hydrocarbon Solvents.*

There are three key elements to the Halogenated Hydrocarbon (HHC) solvent hazard.

**1. The presence of HHC solvents.** 1,1,1-Trichloro ethane and Methylene Chloride are the most common of these solvents. However, other HHC solvents are suspect if used; either as part of paint or adhesives formulation, or for clean-up or flushing.

**2. Aluminum or Galvanized Parts.** Most handling equipment contains these elements. In contact with these metals, HHC solvents could generate a corrosive reaction of a catalytic nature.

**3. Equipment capable of withstanding pressure.**

When HHC solvents contact aluminum or galvanized parts inside a closed container, such as a pump, spray gun, or fluid handling system, the chemical reaction can, over time, result in a build-up of heat and pressure, which can reach explosive proportions.

When all three elements are present, the result can be an extremely violent explosion. The reaction can be sustained with very little aluminum or galvanized metal: any amount of aluminum is too much.

The reaction is unpredictable. Prior use of an HHC solvent without incident (corrosion or explosion) does NOT mean that such use is safe. These solvents can be dangerous alone (as a clean-up or flushing agent) or when used as a component of a coating material. There is no known inhibitor that is effective under all circumstances. Furthermore, the mixing of HHC solvents with other materials or solvents such as MEK, alcohol, and toluene, may render the inhibitors ineffective.

The use of reclaimed solvents is particularly hazardous. Reclaimers may not add any inhibitors, or may add incorrect amounts of inhibitors, or may add improper types of inhibitors. Also, the possible presence of water in reclaimed solvents could feed the reaction.

Anodized or other oxide coatings cannot be relied upon to prevent the explosive reaction. Such coatings can be worn, cracked, scratched, or too thin to prevent contact. There is no known way to make oxide coatings or to employ aluminum alloys, which will safely prevent the chemical reaction under all circumstances.

Several solvent suppliers have recently begun promoting HHC solvents for use in coating systems. The increasing use of HHC solvents is increasing the risk. Because of their exemption from many State Implementation Plans as Volatile Organic Compounds (VOC's), their low flammability hazard, and their not being classified as toxic or carcinogenic substances, HHC solvents are very desirable in many respects.

## Section 4 - Safety Information: General Safety

### WARNING

If you are now using Halogenated Hydrocarbon solvents in pressurized fluid systems having aluminum or galvanized wetted parts, IMMEDIATELY TAKE THE FOLLOWING STEPS:

- Empty system, shut-off, completely depressurize in accordance with equipment service instructions.
- Remove equipment from service, disassemble in accordance with equipment servicing instructions.
- Inspect all parts for corrosion and/or wear. Replace any damaged parts.
- Thoroughly clean all parts of the equipment with a non-halogenated solvent and reassemble in accordance with equipment servicing instructions.
- Flush equipment with non-halogenated solvent.
- Do NOT reuse equipment with HHC solvents or with materials containing such solvents.
- Material suppliers and/or container labels should be consulted to ensure that the solvents used are compatible with your equipment.

 GlasCraft is aware of NO stabilizers available to prevent Halogenated Hydrocarbon solvents from reaction under all conditions with aluminum components in a closed fluid system.

### TAKE IMMEDIATE ACTION...

Halogenated Hydrocarbon solvents are dangerous when used with aluminum components in a closed fluid system. Consult your material supplier to determine whether your solvent or coating contains Halogenated Hydrocarbon Solvents.

GlasCraft recommends that you contact your solvent supplier regarding the best non-flammable clean-up solvent with the heat toxicity for your application.

If, however, you find it necessary to use flammable solvents, they must be kept in approved, electrically grounded containers.

Bulk solvent should be stored in a well-ventilated, separate building, 50 feet away from your main plant.

You should allow only enough solvent for one day's use in your laminating area.

"NO SMOKING" signs must be posted and observed in all areas of storage or where solvents and other flammable materials are used.

Adequate ventilation (as covered in OSHA Section 1910.94 and NFPA No. 91) is important wherever solvents are stored or used, to minimize, confine and exhaust the solvent vapors.

Solvents should be handled in accordance with OSHA Section 1910.106 and 1910.107.

### Toxicity of Chemicals

GlasCraft recommends that you consult OSHA Sections 1910.94, 1910.106, 1910.107 and NFPA No. 33, Chapter 14, and NFPA No. 91.

Contact your chemical supplier(s) and determine the toxicity of the various chemicals used, as well as the best methods to prevent injury, irritation and danger to personnel.

Also determine the best methods of first aid treatment for each chemical used in your plan

### First Aid

If chemicals containing isocyanate are splashed on the skin, they can produce ill effects. Steps to counteract such effects should be started immediately.

Apply Tincture of Green Soap, full strength, to the contaminated area. If Tincture of Green Soap is not immediately available, wash the exposed area repeatedly with soap and water. Soap and water is not as desirable as using Tincture of Green Soap because many isocyanate components are not easily dissolved in water. In addition, soap and water does not form a barrier to the isocyanate.

After approximately two to four minutes, wash off the Tincture of Green Soap with water. If there is still an indication of isocyanate present, repeat the application. If the isocyanate contamination is on the facial area, care must be taken to avoid getting the Tincture of Green Soap in the eyes.

If the person develops breathing difficulties, oxygen should be administered. Quite often the exposed person will experience residual effects such as coughing spells. CONTACT PHYSICIAN IMMEDIATELY.

### WARNING

Contact a doctor immediately in the event of an injury and give him the information you have collected. If your information includes first aid instructions, administer first aid immediately while you are contacting the doctor.



## Section 4 - Safety Information: General Safety

If a person accidentally swallows isocyanate, large amounts of water should be swallowed immediately. Vomiting should then be induced by patient sticking his finger down his throat, or by swallowing large quantities of warm salt water or warm soapy water. After vomiting, more water should be taken to dilute isocyanate further. CONTACT PHYSICIAN IMMEDIATELY.

### Ventilation



*Hazardous concentrations of some chemical vapors exist before they can be smelled. Chemical component suppliers should be contacted to determine at what concentrations the vapors of the chemicals they supply become dangerous, and the procedures and equipment needed to detect such dangerous concentrations. Such equipment should be obtained.*

*Adequate ventilation must be provided in any area where foam chemicals are sprayed or poured, and wherever the material containers are opened.*

In industrial applications, foaming operations should be restricted to specific areas, and proper ventilation should be provided in these areas to prevent chemical vapors from spreading. Spray foaming operations MUST be restricted to a spray booth where a minimum exhaust of 100 feet per minute at the face of the booth is provided. Special care should be taken to prevent unsuspecting personnel both inside and outside of the plant from being exposed to chemical vapors. The chemical vapors should be exhausted to atmosphere in such a manner and at a sufficiently low concentration that personnel outside the plant are not exposed to dangerous concentrations of chemical vapors. Refer to OSHA Standards, sub-part G, 1910.107 and particularly sub-section (m) for Federal standards. State and local authorities may have applicable statutes or regulations concerning ventilation.

In contractor applications (for example, at a construction site, inside building or other enclosed space), the forced ventilation normally provided is likely to be inadequate. These applications, therefore, usually REQUIRE the use of forced, fresh air respirators for all persons in the areas where foaming operations are conducted or where the chemical vapors are likely to spread.

In industrial and contractor applications, it is advisable to run frequent tests to determine the exact concentration of isocyanate vapor in the air. Industrial equipment is available for making such determinations. Your chemical supplier can recommend such equipment and procedures.

### Proper Safety Equipment

All persons spraying or working in areas where forced air ventilation is not adequate to remove isocyanate vapors from the air MUST use an approved (U.S. Bureau of Mines) fresh air supplied respirator.

Respirators should be regularly inspected, cleaned and disinfected according to good practices. Records must be kept of the inspections. The user MUST have a medical clearance indicating that he can safely use a respirator.

Respirators must fit securely; beards prevent a tight seal around the face. Eye glasses have to be given special attention and contact lenses are prohibited.

Safety goggles, gloves and other protective devices are suggested for operators of foaming equipment. Refer to OSHA Standards, sub-part 1, 1910.132, 1910.133 and 1910.134 for Federal standards.

IF YOU HAVE ANY QUESTIONS REGARDING THE ABOVE PRECAUTIONS OR ANY SERVICE OR OPERATION PROCEDURES, CALL YOUR GLASCRAFT DISTRIBUTOR OR GLASCRAFT, INC.

### NOTICE

*All statements, information and data given herein are believed to be accurate and reliable but are presented without guaranty, warranty or responsibility of any kind expressed or implied. The user should not assume that all safety measures are indicated or that other measures are not required.*



5845 WEST 82nd STREET, SUITE 102  
INDIANAPOLIS, INDIANA 46278 U.S.A.

PHONE (317) 875-5592

FAX (317) 875-5456



## Section 4 - Safety Information: Limited Warranty Policy

GLASCRAFT, INC. ("GlasCraft") warrants to the original Purchaser of GlasCraft manufactured equipment and parts, that all GlasCraft manufactured equipment and parts will conform to their published written specifications and be free of defects in workmanship and material for a period of one (1) year from the original date of installation. GlasCraft makes no warranty to anyone other than the original Purchaser.

If any GlasCraft manufactured part or equipment is found to be defective in workmanship or material within the one-year period from the date of installation, as determined solely by GlasCraft, GlasCraft, in its sole discretion, will either repair or replace the defective part or equipment at GlasCraft's cost, including freight charges both ways, or credit or refund the purchase price for the defective equipment or part.

A warranty claim will be honored only when:

1. GlasCraft has been informed, in writing, of any such defect in workmanship or material within ten (10) days after discovery by the original Purchaser;
2. An official of GlasCraft has issued a return authorization number; and
3. The claimed defective equipment or part has been returned to GlasCraft by the original Purchaser, freight prepaid (with proper return authorization number(s) attached), to: GlasCraft, Inc., 5845 West 82nd Street, Suite 102, Indianapolis, IN 46278, U.S.A.

This warranty shall not apply to any equipment or parts that have been altered or repaired by anyone other than GlasCraft or to defects or damage resulting from improper installation, misuse, negligence, accident, or use not specified by GlasCraft. This warranty shall not apply to any equipment where any parts or components were replaced by any parts or components not manufactured or supplied by GlasCraft. The decision by GlasCraft shall be conclusive and binding on Purchaser.

GlasCraft does not warrant that any equipment or parts sold to Purchaser meet or comply with any local, state, federal, or other jurisdiction's regulations or codes. GlasCraft does not warrant that any equipment or part sold to Purchaser, when used individually or in concert with any other part, equipment, device, component or process, does not infringe on any patent rights of any third party. GlasCraft only warrants that it has no specific knowledge of any such infringement.

GlasCraft makes no warranty as to any parts or equipment manufactured by others. Purchaser shall look solely and only to the manufacturer of such parts or equipment with respect to any warranty claims. GlasCraft hereby assigns to Purchaser the original manufacturer's warranties to all such equipment and parts, to the full extent permitted.

**THE AFORESAID WARRANTY IS IN LIEU OF ALL OTHER WARRANTIES, EXPRESS OR IMPLIED. SPECIFICALLY THERE ARE NO WARRANTIES OF MERCHANTABILITY OR FITNESS FOR A PARTICULAR PURPOSE, WHICH WARRANTIES ARE SPECIFICALLY DISCLAIMED.**

GlasCraft shall not be liable for any loss or expense resulting from damage or accidents caused by improper use or application of materials manufactured or sold by GlasCraft or its distributors or agents.

**UNDER NO CIRCUMSTANCES SHALL GLASCRAFT'S LIABILITY EXCEED THE AMOUNT PURCHASER PAID FOR THE CLAIMED DEFECTIVE EQUIPMENT OR PART. UNDER NO CIRCUMSTANCES SHALL GLASCRAFT BE LIABLE FOR INCIDENTAL OR CONSEQUENTIAL DAMAGES OR FOR LOST PROFITS.**

No action arising from or relating to any goods manufactured by or purchased from GlasCraft may be brought more than one (1) year after the cause of action accrues.

## Section 4 - Safety Information: Technical Assistance.....

### **Thank You for selecting GlasCraft spray equipment**

Should you have any questions or need technical assistance, contact your factory authorized GlasCraft distributor.

Distributor: \_\_\_\_\_

Phone: \_\_\_\_\_

Contact: \_\_\_\_\_



For any issues your distributor cannot address, the GlasCraft technical service department is always available to assist you with the operation of your spray equipment. To help our technical representatives expedite your call and better address your questions, please have the following information ready and available when you phone GlasCraft.

**\* If your questions are not urgent, You can e-mail all correspondence to [service@glascraft.com](mailto:service@glascraft.com)**

Model: \_\_\_\_\_

Serial number: \_\_\_\_\_

Type of spray gun: \_\_\_\_\_

Serial number: \_\_\_\_\_

Is your equipment:

Single phase: \_\_\_\_\_ Three phase \_\_\_\_\_

What is the inbound voltage  
to your equipment: \_\_\_\_\_

Temperature setting ISO: \_\_\_\_\_

Temperature setting POLY: \_\_\_\_\_

Temperature setting HOSE: \_\_\_\_\_

### **For Air Powered Systems:**

Air compressor size: \_\_\_\_\_

CFM generated: \_\_\_\_\_

Pressure at the system:

Hydraulic \_\_\_\_\_ Pneumatic \_\_\_\_\_

Dynamic fluid pressure:

ISO \_\_\_\_\_ POLY \_\_\_\_\_

Spray gun chamber size: \_\_\_\_\_

Material being sprayed: \_\_\_\_\_

Viscosity: ISO \_\_\_\_\_ POLY \_\_\_\_\_

Approximate material temperature: \_\_\_\_\_

For Your Reference



**Date Purchased** \_\_\_\_\_  
**Distributor** \_\_\_\_\_  
\_\_\_\_\_  
**Contact** \_\_\_\_\_  
**Phone** \_\_\_\_\_  
**E-mail** \_\_\_\_\_

GlasCraft manufactures a complete line of polyurethane foam and polyurea coating spray systems. If your application is in-plant or a field contractor - GlasCraft has a system package to meet your requirements.

***GUARDIAN - AIR POWERED / A5 & A6 SERIES EQUIPMENT***

- . 6000 OR 12000 WATTS OF HEAT
- . 1600, 2200, OR 3000 PRESSURE SET-UPS AVAILABLE

***MH, MH II, & MH III HYDRAULIC POWERED SYSTEMS***

- . UP TO 45 LBS / MINUTE OUTPUT
- . EXCELLENT PERFORMANCE AND RELIABILITY

***GUARDIAN MMH - MOBILE MODULAR HYDRAULIC SYSTEMS***

- . SPECIFICALLY DESIGNED FOR ANY TYPE OF SPRAY RIG
- . GIVE COMPLETE UTILIZATION OF FLOOR SPACE IN MOBILE RIG

***PROBLER P2 SPRAY GUN***

- . IMPINGEMENT MIX / AIR PURGE
- . OPTIONAL NOZZLE FOR SPRAYING STUD WALLS, POURING & STREAM JET

For more information concerning any of these GlasCraft products,  
contact your local authorized GlasCraft distributor or visit [www.glascraft.com](http://www.glascraft.com)

Quality and Performance...

GENUINE GLASCRAFT

**Glas** **Craft**

DISPENSING EXCELLENCE



[www.glascraft.com](http://www.glascraft.com)

**GC-1397**  
**REVISION A.2**

5845 WEST 82nd STREET  
INDIANAPOLIS, INDIANA 46278  
U.S.A.

Phone (317) 875-5592  
Fax (317) 875-5456  
E-Mail [sales@glascraft.com](mailto:sales@glascraft.com)