

RS™ Gun and Cutter

3A0232U

EN

For use with polyester resin and gel-coat.

For professional use only.



Important Safety Instructions

Read all warnings and instructions in this manual. Save these instructions.

See page 3 for model information, including maximum working pressure.

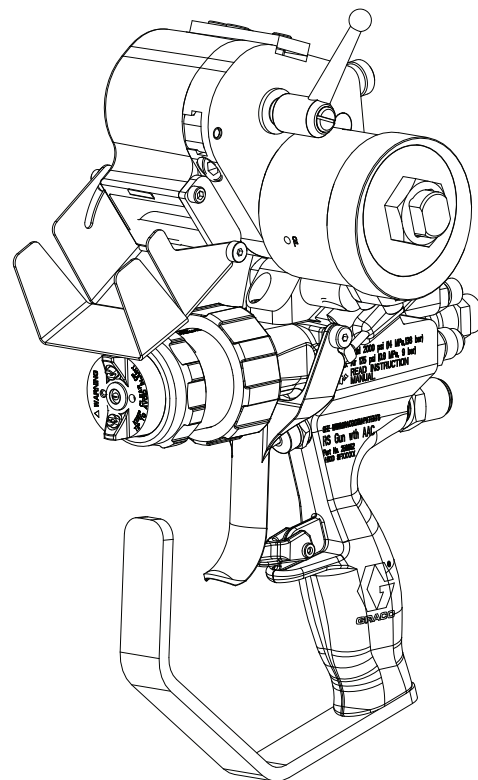

External Mix Chop Gun with Cutter shown



II 2 G c T6

Contents

Models	3
Related Manuals	3
Warnings	4
Important Two-Component Information	6
Material Self-ignition	6
Keep Components A and B Separate	6
Changing Materials	6
Important Methyl Ethyl Ketone Peroxide (MEKP)	
Safety Information	7
Component Identification	10
External Mix Gel Gun, 258840	10
Internal Mix Gel Gun, 258853	11
Internal Mix Chop Gun, 258854	12
Internal Mix Chop Gun, 24P436, High Flow, Carbide Seat	13
External Mix Chop Gun, 258852	14
Theory of Operation	15
External Mix	15
Internal Mix	15
Chop Guns	15
Impingement versus Airless Spray Tips	15
Air Assist Containment™ (AAC™)	15
Grounding	15
Introduction	15
Setup	16
Startup	18
Operation	19
Trigger Lock	19
Adjust AAC	19
Internal Mix Flush	19
Pressure Relief Procedure	20
Shutdown	21
Daily Shutdown	21
Long-Term Shutdown	23
Maintenance	24
Flush System	24
Troubleshooting	25
Fluid Leaking from Front of Gun	29
Adjust Trigger Clamp	29
Fluid Leaking from Under Trigger Clamp Assembly 30	30
Adjust Needle Packing Tension	30
Adjust Actuator Pin Adjustment Screws	31

Repair	32
Remove Hardened Material from Internal Mix Front Head	32
Replace Internal Mix Element	34
Replace External Mix Check Valve and O-Rings	35
Replace Material Needle Assembly	36
Replace Center Needle Assembly	36
Replace Needle Packing	37
Parts	38
External Mix Gel Gun, 258840	38
Internal Mix Gel Gun, 258853	40
External Mix Chop Gun with Cutter, 258970	42
Internal Mix Chop Gun with Cutter, 258971	42
Internal Mix, High Flow, Chop Gun with Cutter, 24P435	42
Chop Guns	43
Front Head Assemblies	49
Needle Assembly, 24E417	52
O-ring Identification	53
Accessories	54
Fusion® Grease	54
INDy or Formula Adapter Kit, 125797	54
LPA2 Adapter Kit, 125843	54
Universal Adapter Kit, 257754	54
Resin Transfer Molding (RTM) Nozzle Adapter Kit, 16T680	54
Casting Nozzle Adapter Kit, 16T707	54
External Mix High-Flow Kit, 24H336	54
Internal Mix High-Flow Kit, 24H337	54
AAC Regulators	55
External Mix Gel Gun to Chop Gun Conversion	55
Internal Mix Gel Gun to Chop Gun Conversion	55
Pressure Fed Roller Adapter Kit, 16T708	56
Extension Gelcoat Spraying Kit, 16T709	56
Tools	56
Carbide Resin Seat, 16N889	56
External Mix Chopper Extension Kit, 24V096	56
Impingement Spray Tips	58
Airless Spray Tips	61
Technical Data	63
Dimensions	65
Graco Standard Warranty	66
Graco Information	66

Models

See **Technical Data** on page 63 for more specifications.

Model	Description	Maximum Fluid Working Pressure psi (MPa, bar)	Maximum Catalyst Working Pressure psi (MPa, bar)	Air Inlet Working Pressure Range psi (MPa, bar)	Maximum Fluid Temperature °F (°C)
258853	Internal Mix Gel Gun	2000 (14, 138)	2000 (14, 138)	0-125 (0-0.86, 0-8.6)	100 (38)
258854	Internal Mix Chop Gun, No Cutter	2000 (14, 138)	2000 (14, 138)	0-125 (0-0.86, 0-8.6)	100 (38)
258971	Internal Mix Chop Gun, Cutter	2000 (14, 138)	2000 (14, 138)	80-125 (0.55-0.86, 5.5-8.6)	100 (38)
24P435	Internal Mix Chop Gun, High Flow, Cutter	2000 (14, 138)	2000 (14, 138)	80-125 (0.55-0.86, 5.5-8.6)	100 (38)
258840	External Mix Gel Gun	2000 (14, 138)	200 (1.4, 14)	0-125 (0-0.86, 0-8.6)	100 (38)
258852	External Mix Chop Gun, No Cutter	2000 (14, 138)	200 (1.4, 14)	0-125 (0-0.86, 0-8.6)	100 (38)
258970	External Mix Chop Gun, Cutter	2000 (14, 138)	200 (1.4, 14)	80-125 (0.55-0.86, 5.5-8.6)	100 (38)
24P436	Internal Mix Chop Gun, High Flow	2000 (14, 138)	2000 (14, 138)	80-125 (0.55-0.86, 5.5-8.6)	100 (38)





Related Manuals





The following is a list of component manuals written in English. These manuals and any translated versions available can be found at www.graco.com.

Part	Description
3A1226	Universal Adapter Kit 257754 Instructions
3A2054	Indy or Formula Adapter Kit 125797 Instructions
3A2079	LPA2 Adapter Kit 125843 Instructions
332574	RS Gun Cutter Assemblies Operation-Repair
334010	RS Gun External Mix Chopper Extension Kit 24V096 Instructions

Warnings



The following warnings are for the setup, use, grounding, maintenance, and repair of this equipment. The exclamation point symbol alerts you to a general warning and the hazard symbols refer to procedure-specific risks. When these symbols appear in the body of this manual, refer back to these Warnings. Product-specific hazard symbols and warnings not covered in this section may appear throughout the body of this manual where applicable.

 WARNING	
	<p>FIRE AND EXPLOSION HAZARD</p> <p>Flammable fumes, such as solvent and paint fumes, in work area can ignite or explode. To help prevent fire and explosion:</p> <ul style="list-style-type: none"> • Use equipment only in well ventilated area. • Eliminate all ignition sources; such as pilot lights, cigarettes, portable electric lamps, and plastic drop cloths (potential static arc). • Keep work area free of debris, including solvent, rags and gasoline. • Do not plug or unplug power cords, or turn power or light switches on or off when flammable fumes are present. • Ground all equipment in the work area. See Grounding instructions. • Use only grounded hoses. • Hold gun firmly to side of grounded pail when triggering into pail. • If there is static sparking or you feel a shock, stop operation immediately. Do not use equipment until you identify and correct the problem. • Keep a working fire extinguisher in the work area.
	<p>SKIN INJECTION HAZARD</p> <p>High-pressure fluid from dispensing device, hose leaks, or ruptured components will pierce skin. This may look like just a cut, but it is a serious injury that can result in amputation. Get immediate surgical treatment.</p> <ul style="list-style-type: none"> • Engage trigger lock when not dispensing. • Do not point dispensing device at anyone or at any part of the body. • Do not put your hand over the fluid outlet. • Do not stop or deflect leaks with your hand, body, glove, or rag. • Follow the Pressure Relief Procedure when you stop dispensing and before cleaning, checking, or servicing equipment. • Tighten all fluid connections before operating the equipment. • Check hoses and couplings daily. Replace worn or damaged parts immediately.
	<p>MOVING PARTS HAZARD</p> <p>Moving parts can pinch, cut or amputate fingers and other body parts.</p> <ul style="list-style-type: none"> • Keep clear of moving parts. • Do not operate equipment with protective guards or covers removed. • Pressurized equipment can start without warning. Before checking, moving, or servicing equipment, follow the Pressure Relief Procedure and disconnect all power sources.



 WARNING	
	<p>TOXIC FLUID OR FUMES HAZARD</p> <p>Toxic fluids or fumes can cause serious injury or death if splashed in the eyes or on skin, inhaled, or swallowed.</p> <ul style="list-style-type: none"> • Read MSDSs to know the specific hazards of the fluids you are using. • Store hazardous fluid in approved containers, and dispose of it according to applicable guidelines. • Always wear chemically impermeable gloves when spraying, dispensing, or cleaning equipment.
	<p>PERSONAL PROTECTIVE EQUIPMENT</p> <p>You must wear appropriate protective equipment when operating, servicing, or when in the operating area of the equipment to help protect you from serious injury, including eye injury, hearing loss, inhalation of toxic fumes, and burns. This equipment includes but is not limited to:</p> <ul style="list-style-type: none"> • Protective eyewear, and hearing protection. • Respirators, protective clothing, and gloves as recommended by the fluid and solvent manufacturer.
	<p>EQUIPMENT MISUSE HAZARD</p> <p>Misuse can cause death or serious injury.</p> <ul style="list-style-type: none"> • Do not operate the unit when fatigued or under the influence of drugs or alcohol. • Do not exceed the maximum working pressure or temperature rating of the lowest rated system component. See Technical Data in all equipment manuals. • Use fluids and solvents that are compatible with equipment wetted parts. See Technical Data in all equipment manuals. Read fluid and solvent manufacturer's warnings. For complete information about your material, request MSDS from distributor or retailer. • Do not leave the work area while equipment is energized or under pressure. Turn off all equipment and follow the Pressure Relief Procedure when equipment is not in use. • Check equipment daily. Repair or replace worn or damaged parts immediately with genuine manufacturer's replacement parts only. • Do not alter or modify equipment. • Use equipment only for its intended purpose. Call your distributor for information. • Route hoses and cables away from traffic areas, sharp edges, moving parts, and hot surfaces. • Do not kink or over bend hoses or use hoses to pull equipment. • Keep children and animals away from work area. • Comply with all applicable safety regulations.
	<p>PRESSURIZED ALUMINUM PARTS HAZARD</p> <p>Use of fluids that are incompatible with aluminum in pressurized equipment can cause serious chemical reaction and equipment rupture. Failure to follow this warning can result in death, serious injury, or property damage.</p> <ul style="list-style-type: none"> • Do not use 1,1,1-trichloroethane, methylene chloride, other halogenated hydrocarbon solvents or fluids containing such solvents. • Many other fluids may contain chemicals that can react with aluminum. Contact your material supplier for compatibility.

Important Two-Component Information

Material Self-ignition

						
<p>Some materials may become self-igniting if applied too thickly. Read material manufacturer's warnings and material MSDS.</p>						

Keep Components A and B Separate

						
<p>Cross-contamination can result in cured material in fluid lines which could cause serious injury or damage equipment. To prevent cross-contamination of the equipment's wetted parts, never interchange component A (catalyst) and component B (resin) parts.</p>						

Changing Materials

- When changing materials, flush the equipment multiple times to ensure it is thoroughly clean.
- Always clean the fluid inlet strainers after flushing.
- Check with your material manufacturer for chemical compatibility.

Important Methyl Ethyl Ketone Peroxide (MEKP) Safety Information

MEKP is among the more hazardous materials found in commercial channels. Proper handling of the “unstable (reactive)” chemicals presents a definite challenge to the plastics industry. The highly reactive property which makes MEKP valuable to the plastics industry in producing the curing reaction of polyester resins and gel-coats also produces the hazards which require great care and caution in its storage, transportation, handling, processing and disposal.

Workers must be thoroughly informed of the hazards that may result from improper handling of MEKP, especially in regards to contamination and heat. They must be thoroughly instructed regarding the proper action to be taken in the storage, use and disposal of MEKP and other hazardous materials used in the laminating operation.

Current catalysts are premixed and do not require any diluents. Graco strongly recommends that diluents not be used. Diluents add to the possibility of contaminates entering the catalyst system. Never dilute MEKP with acetone or any solvent since this can produce an extremely shock-sensitive compound which can explode.

Use only original equipment or equivalent parts from Graco in the catalyst system (i.e.: hoses, fittings, etc.) because a hazardous chemical reaction may result between substituted parts and MEKP.

To prevent contact with MEKP, appropriate personal protective equipment, including chemically impermeable gloves, boots, aprons and goggles are required for everyone in the work area.

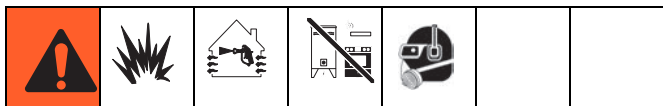

MEKP is flammable and potentially explosive, as well as potentially damaging to the eyes and skin. Read material manufacturer’s warnings and material MSDS to know specific hazards and precautions related to MEKP.

Contaminated MEKP can become explosive. Prevent contamination of MEKP with other materials, which includes, but is not limited to polyester overspray, polymerization accelerators and promoters, and non-stainless metals. Even small amounts of contaminates can make MEKP explosive. This reaction may start slowly, and gradually build-up heat, which can accelerate until fire or an explosion result. This process can take from seconds to days.

Heat applied to MEKP, or heat build-up from contamination reactions can cause it to reach what is called its Self-Accelerating Decomposition Temperature (SADT), which can cause fire or explosion. Spills should be promptly removed, so no residues remain. Spillage can heat up to the point of self-ignition. Dispose in accordance with manufacturer's recommendation.

Store MEKP in a cool, dry and well-ventilated area in the original containers away from direct sunlight and away from other chemicals. It is strongly recommended that the storage temperature remain below 86° F (30° C). Heat will increase the potential for explosive decomposition. Refer to NFPA 432. Keep MEKP away from heat, sparks and open flames.

Polyester Resins and Gel-Coats



Spraying materials containing polyester resin and gel-coats creates potentially harmful mist, vapors and atomized particulates. Prevent inhalation by providing sufficient ventilation and the use of respirators in the work area.

Read the material manufacturer's warnings and material MSDS to know specific hazards and precautions related to polyester resins and gel-coats.

To prevent contact with polyester resins and gel-coats, appropriate personal protective equipment, including chemically impermeable gloves, boots, aprons and goggles are required for everyone in the work area.

Spraying and Lamination Operations

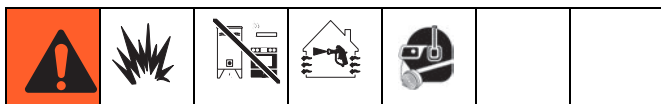

Remove all accumulations of overspray, FRP sandings, etc. from the building as they occur. If this waste is allowed to build up, spillage of catalyst is more likely to start a fire.

If cleaning solvents are required, read material manufacturer's warnings and material MSDS to know specific hazards and precautions. (Graco recommends that clean-up solvents be nonflammable.)

NOTE: Graco recommends that you consult OSHA Sections 1910.94, 1910.106, 1910.107 and NFPA No. 33, Chapter 16,17, and NFPA No. 91 for further guidance.

Component Identification

External Mix Gel Gun, 258840

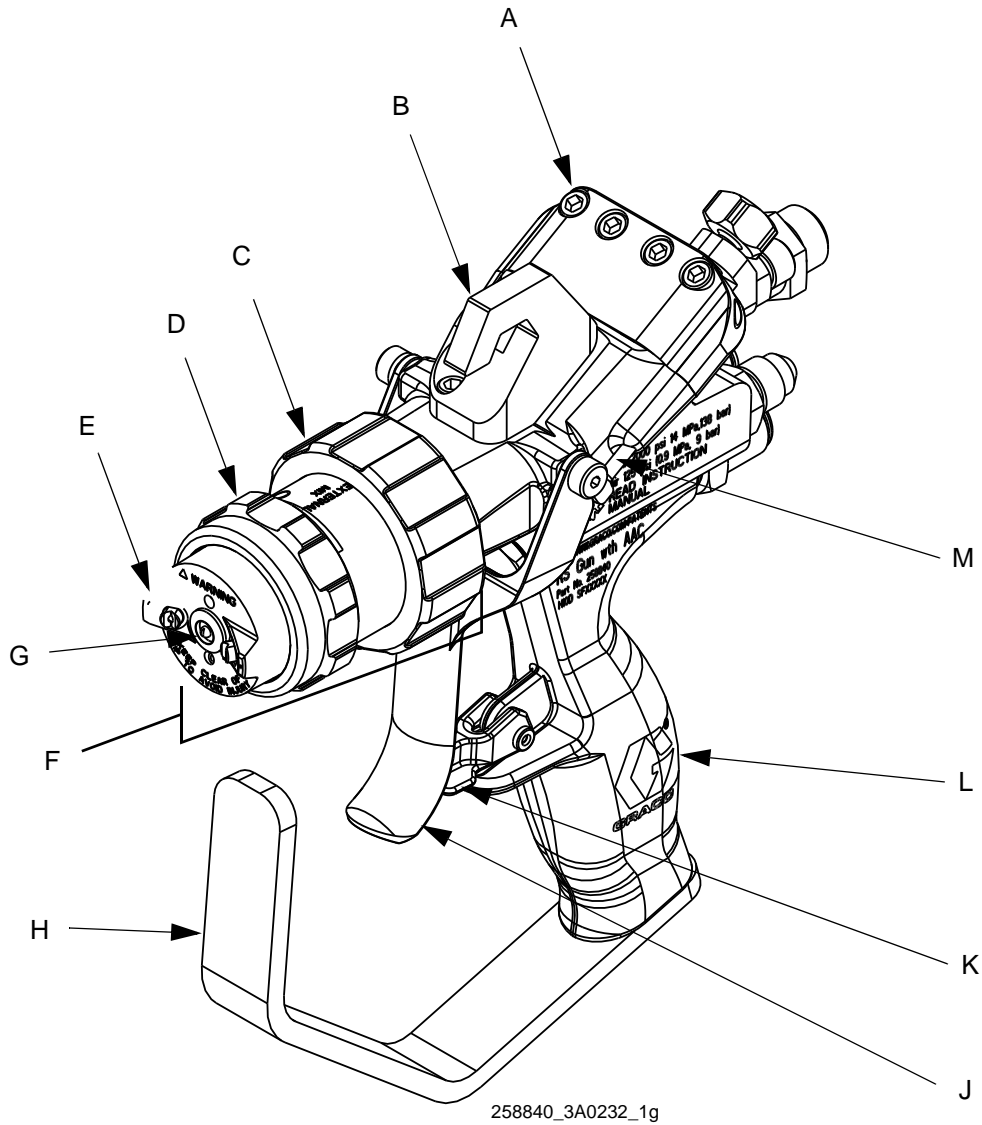

Key:

- | | |
|---------------------------|-----------------|
| A Trigger Clamp Assembly | G Spray Tip |
| B Gun Mount | H Trigger guard |
| C Front Head Locking Ring | J Trigger |
| D Air Cap Retaining Ring | K Trigger lock |
| E External Mix Aircap | L Handle |
| F External Mix Front Head | M Actuator Pin |

FIG. 1

Internal Mix Gel Gun, 258853

NOTE: On internal mix guns, the tip rotates to allow a vertical or horizontal spray pattern.

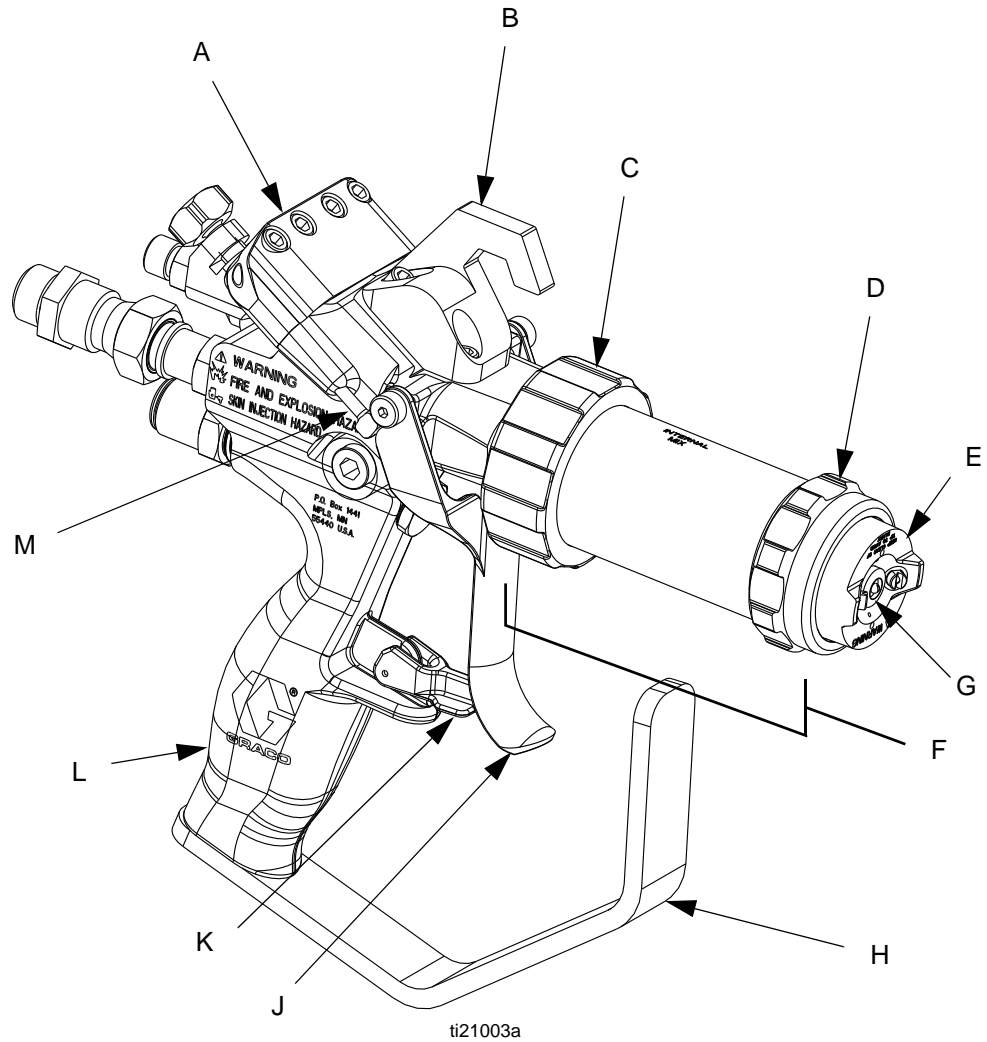

Key:

- | | | | |
|---|-------------------------|---|---------------|
| A | Trigger Clamp Assembly | G | Spray Tip |
| B | Gun Mount | H | Trigger guard |
| C | Front Head Locking Ring | J | Trigger |
| D | Air Cap Retaining Ring | K | Trigger lock |
| E | Internal Mix Aircap | L | Handle |
| F | Internal Mix Front Head | M | Actuator Pin |

FIG. 2

Internal Mix Chop Gun, 258854

NOTE: On internal mix guns, the tip rotates to allow vertical or horizontal spray pattern.

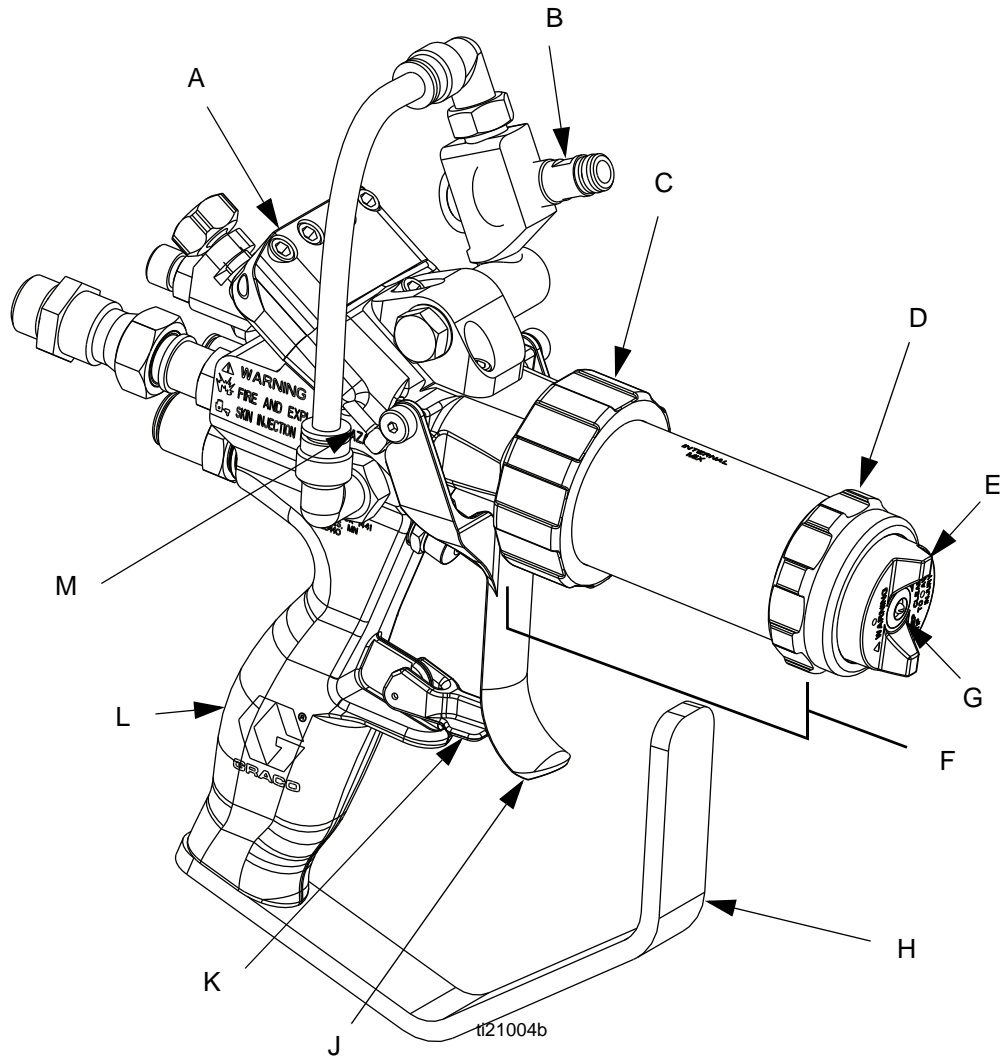

Key:

- | | | | |
|---|-------------------------|---|---------------|
| A | Trigger Clamp Assembly | G | Spray Tip |
| B | Cutter Mount | H | Trigger guard |
| C | Front Head Locking Ring | J | Trigger |
| D | Air Cap Retaining Ring | K | Trigger lock |
| E | Internal Mix Aircap | L | Handle |
| F | Internal Mix Front Head | M | Actuator Pin |

FIG. 3

Internal Mix Chop Gun, 24P436, High Flow, Carbide Seat

NOTE: On internal mix guns, the tip rotates to allow vertical or horizontal spray pattern.

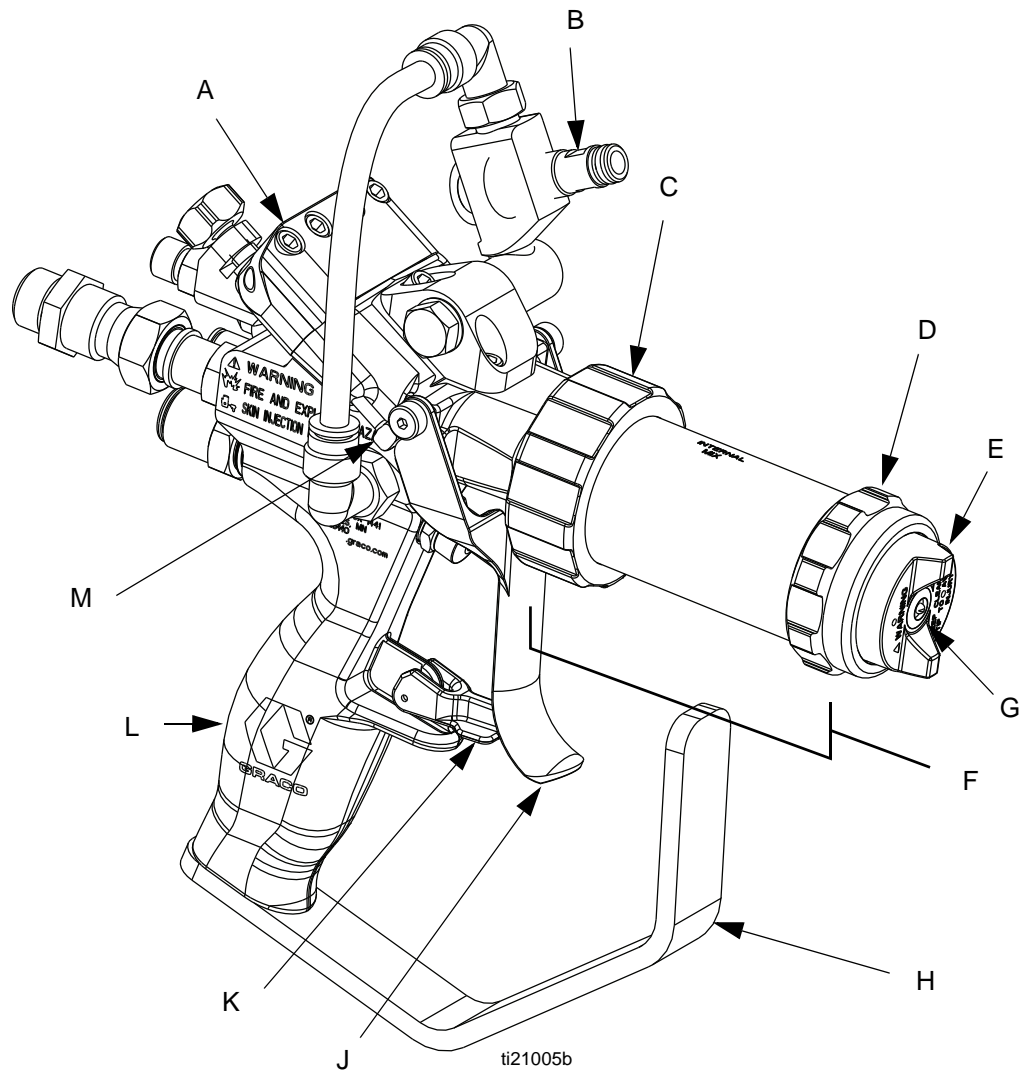

Key:

- | | | | |
|---|---------------------------------------|---|---------------|
| A | Trigger Clamp Assembly | G | Spray Tip |
| B | Cutter Mount | H | Trigger guard |
| C | Front Head Locking Ring | J | Trigger |
| D | Air Cap Retaining Ring | K | Trigger lock |
| E | Internal Mix Aircap | L | Handle |
| F | Internal Mix Front Head,
High Flow | M | Actuator Pin |

FIG. 4

External Mix Chop Gun, 258852

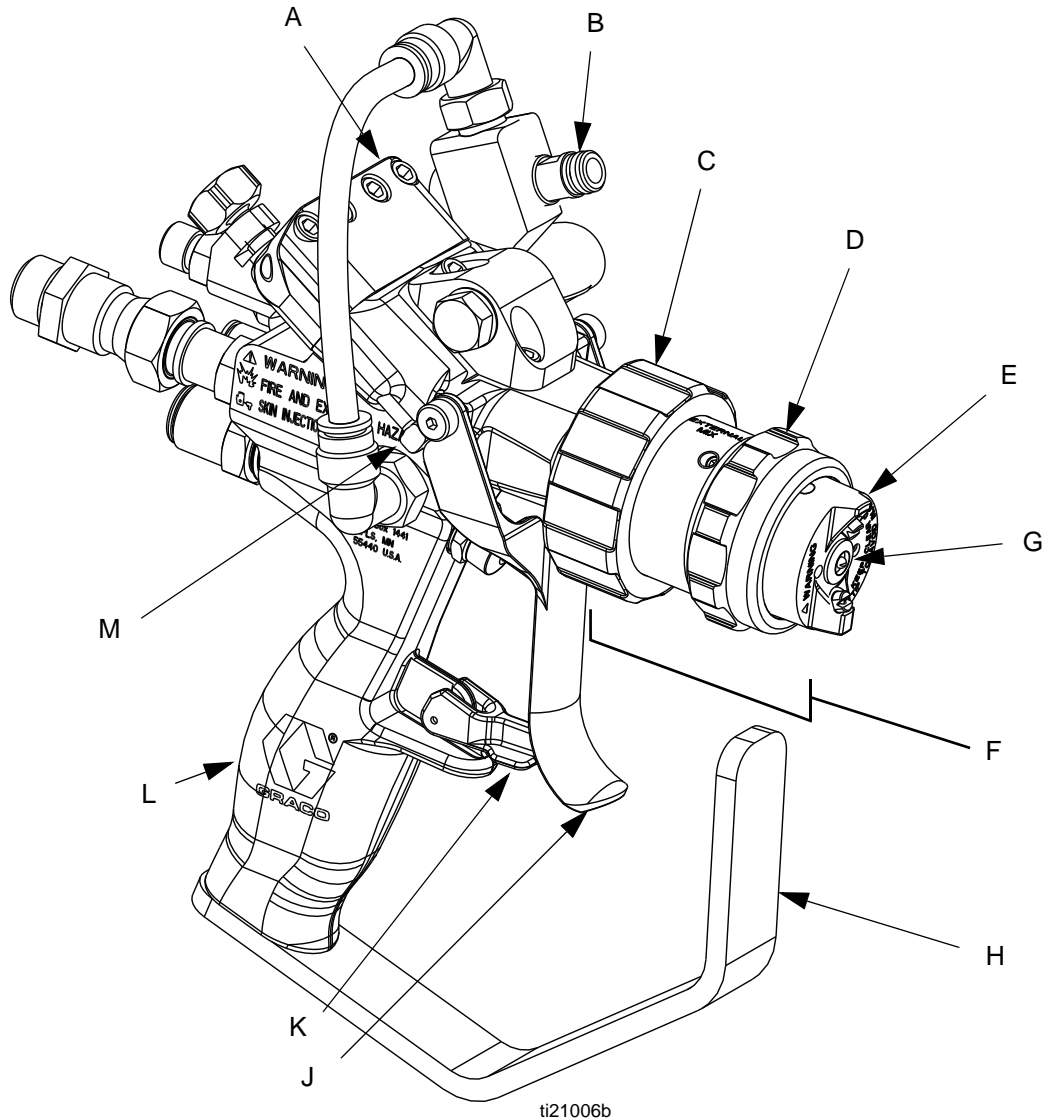

Key:

- | | | | |
|---|-------------------------|---|---------------|
| A | Trigger Clamp Assembly | G | Spray Tip |
| B | Cutter Mount | H | Trigger guard |
| C | Front Head Locking Ring | J | Trigger |
| D | Air Cap Retaining Ring | K | Trigger lock |
| E | External Mix Aircap | L | Handle |
| F | External Mix Front Head | M | Actuator Pin |

Fig. 5

Theory of Operation

External Mix

The resin or gelcoat stream and the catalyst stream impinge when they exit the spray tip. The catalyst is atomized with air pressure by the AAC air to achieve high mix quality. External mixing reduces internal clogs from cured material.

Internal Mix

The material and catalyst pass through an internal static mixer where they mix. The mixed solution is dispensed.

Chop Guns

Fiberglass is pulled through cutter and cut into small strands. The cut strands are then dispensed into the mixed material stream.

Impingement versus Airless Spray Tips

Impingement spray tips are typically for chop guns. This utilizes multiple impinging streams to create the fan pattern.

Airless spray tips are typically for gel guns. This utilizes a single cat-eye shaped orifice to create the fan pattern.

Air Assist Containment™ (AAC™)

When material exits the spray tip, air is sprayed against the material stream to shape it into a more consistent pattern.

Grounding

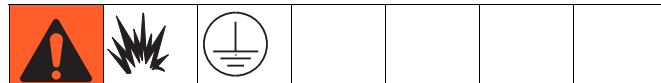

This equipment must be grounded.

Grounding reduces the risk of static shock by providing an escape wire for electrical current due to static build up or in the event of short circuit.

NOTE: Grounding wire and clamp assembly 17440-00 is included with Graco FRP proportioner. If using a different proportioner that does not come with a grounding wire and clamp assembly, order 17440-00 or provide your own.

Ground the dispense gun through connection to a Graco approved grounded fluid supply hose.

Check your local electrical code and related manuals for detailed grounding instructions of all equipment in the work area.

Introduction

To have the optimal RS gun experience, the most important procedures to understand and perform as specified are:

- **Startup** on page 18
- **Adjust Trigger Clamp** on page 29
- **Adjust Anvil to Blade Cartridge Tension.** Refer to RS Gun Cutter Assemblies Operation-Repair manual for details.
- **Daily Shutdown** on page 21

NOTICE

Failure to perform these procedures correctly and according to the prescribed schedule can result in poor mixing, fluid leaking, cured material in the gun, and premature component wear.

Setup

NOTICE

The equipment was tested with lightweight oil, which is left in the fluid passages to protect parts. To avoid contaminating your fluid with oil, flush the equipment with a compatible solvent before using the equipment. See **Flush System**, page 24.

1. **Before first use**, flush the gun. See **Flush System**, page 24.

NOTE: The recommended solvent pressure during flushing is 80-100 psi (550-700 kPa, 5.5-7.0 bar).

2. Engage trigger lock.
3. **For guns with cutters**, install cutter:
 - a. If necessary, use a crescent wrench to adjust pivot (541) so that it is parallel to gun front end and the open end points to the front of the gun. See FIG. 6.

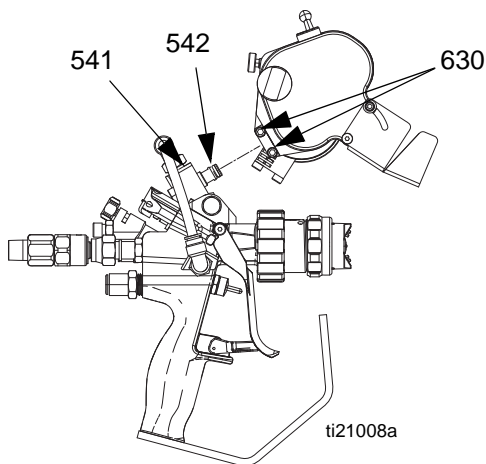

FIG. 6

- b. Back out screws (630). See FIG. 6.
- c. Install cutter onto pivot so glass feed holes are on top.

NOTE: Ensure proper engagement of o-ring (542) into the cutter assembly. Verify there is no excess air leakage because it will greatly reduce the performance of the air motor. See FIG. 6.

- d. Tighten screws (630) to lock cutter in place.

- e. Adjust cutter dispensing angle and chute angle as desired.

4. **For internal mix guns**, verify solvent knob (BD) is adjusted to the fully closed position. See FIG. 7 on page 17.
5. Attach gun connections as described in FIG. 7 on page 17. See **Technical Data** on page 63 for fitting sizes.
6. **For internal mix guns**, prime the solvent line. Turn solvent adjustment knob (BD) until solvent discharges from the front of the gun. See FIG. 7 on page 17.

NOTICE

Internal mix guns: To prevent material curing inside the gun, do not trigger gun if solvent is not primed.

NOTE: The recommended solvent line pressure is 80-100 psi (550-700 kPa, 5.5-7.0 bar).

7. **For guns with cutters**, insert glass strands into feed.
8. **For guns with cutters**, adjust anvil to blade tension. Refer to RS Gun Cutter Assemblies Operation-Repair for part identification:
 - a. Release lockdown.
 - b. Adjust tension knob as desired.
 - c. Tighten lockdown.
 - d. Release idler lock down.
 - e. Adjust idler lock down until it touches anvil.
 - f. Tighten idler lock down.
 - g. Perform test spray to verify proper cutting of glass strands.
 - h. Adjust tension as necessary.
9. **For external mix guns**, adjust AAC knob (BD) to middle of possible range of movement. See FIG. 7 on page 17.

10. Adjust AAC pressure on proportioner.
11. Perform test spray. Adjust system and gun settings as necessary to get desired results.

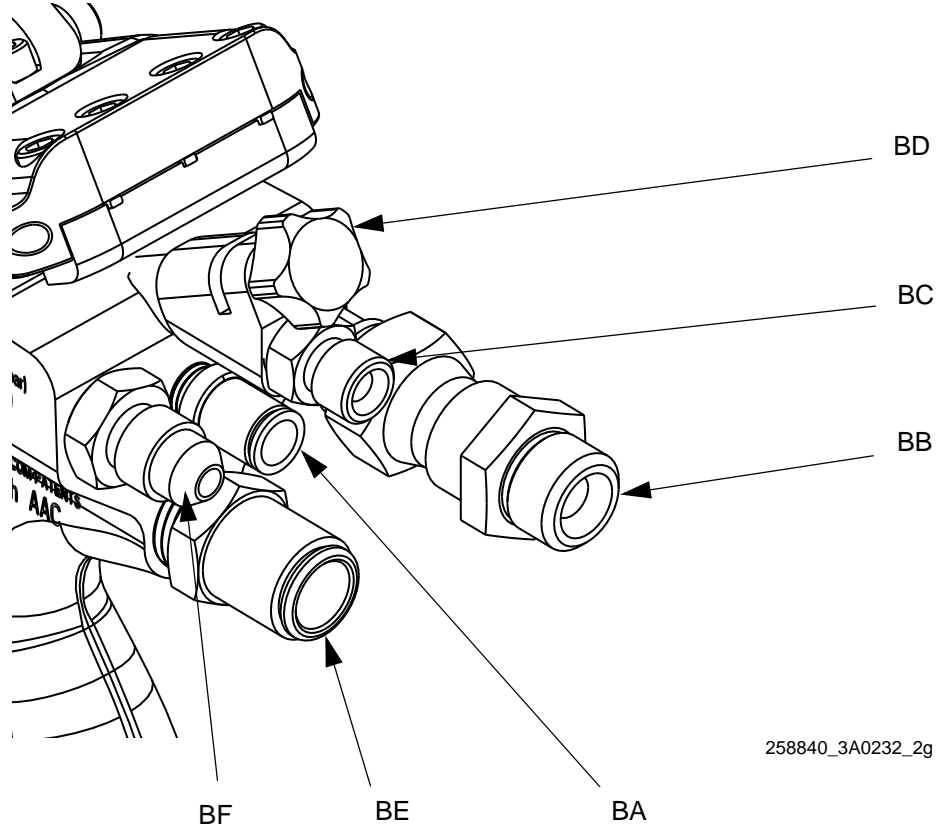

258840_3A0232_2g

Ref	External Mix	Internal Mix Chop	Internal Mix Gel	Fitting Size
BA	Atomized Air (Catalyst)	Air Assist Containment (AAC)	Plugged	1/4 tube
BB	Resin Inlet			1/4 NPSM
BC	Air Assist Containment (AAC)	Solvent		1/8 NPSM
BD	Adjustment Knob			--
BE	Chop Air Inlet		Air Assist Containment (AAC)	3/8 tube
BF	Catalyst Inlet			#4 JIC

FIG. 7: Fitting Details

Startup

1. Inspect o-rings on housings. Replace as needed.
See FIG. 8.

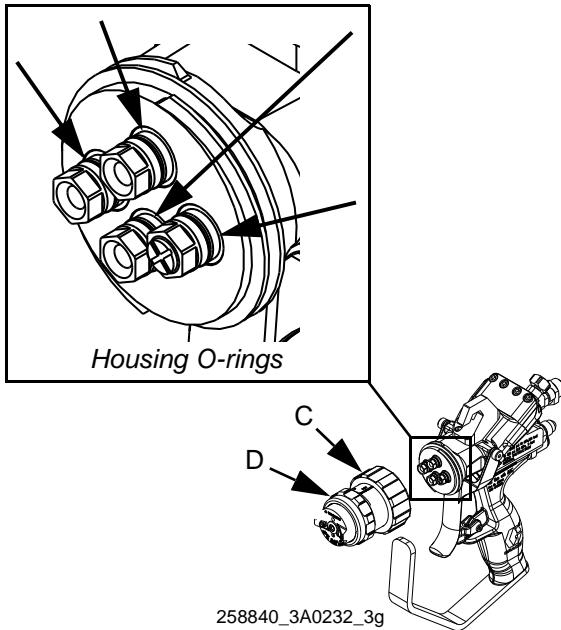

FIG. 8

2. Prime the system as required.

NOTICE

Gun damage can occur when the system is primed with the front head installed. To avoid damage, only prime the system with the front head removed.

3. Align front head with housings and install front head. Tighten front head locking ring (C).
4. Verify air cap retaining ring (D) is tight.



Ensure locking ring (C) and retaining ring (D) are tight before spraying. Spraying while either item is loose may result in skin injection.

5. Verify fluid and air lines are at the desired pressures then begin using the gun.

Operation

--	--	--	--	--	--	--

High-pressure fluid from gun, hose leaks, or ruptured components will pierce skin. This may look like just a cut, but it is a serious injury that can result in amputation. **Get immediate surgical treatment.**

- Do not point gun at anyone or at any part of the body.
- Do not put your hand over the dispense outlet.
- Do not stop or deflect leaks with your hand, body, glove, or rag.
- Follow **Pressure Relief Procedure** when you stop dispensing and before cleaning, checking, or servicing equipment.

Trigger Lock

--	--	--	--	--	--	--

Engage trigger lock whenever you stop spraying to avoid accidental triggering.



Adjust AAC

If the spray pattern is not even, the AAC air pressure may need to be adjusted. For all guns, the AAC air pressure is set at the system. The external mix gun includes an AAC air pressure adjustment on the gun also, see AAC reference in FIG. 7 on page 17. To increase AAC air pressure on the external mix gun, turn knob counter-clockwise. To decrease air pressure, turn knob clockwise. For large changes in AAC air pressure, adjust the pressure at the system.

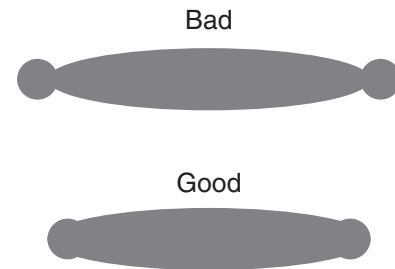

FIG. 9

Internal Mix Flush

--	--	--	--	--	--	--

NOTE: The recommended solvent line pressure is 80-100 psi (550-700 kPa, 5.5-7.0 bar).

After spraying, open the solvent knob (BC) to allow solvent to flow through the gun. See FIG. 7 on page 17. While flushing, hold a metal part of the gun firmly to a grounded metal pail.

Pressure Relief Procedure

1. Shutdown proportioner.
2. Relieve proportioner pressure. See proportioner manual.
3. Engage gun trigger lock.
4. Close the bleed-type master air valve.
5. Disengage the trigger lock.
6. Hold a metal part of the gun firmly to a grounded metal pail. Trigger the gun to relieve pressure.
7. Engage the trigger lock.
8. With a waste container in place, open all fluid drain valves in the system. Leave drain valve(s) open until you are ready to spray again.



9. If you suspect the spray tip or hose is clogged or that pressure has not been fully relieved after following the steps above, **VERY SLOWLY** loosen retaining ring (D) or loosen hose end coupling to relieve pressure gradually, then loosen completely. Clear hose or tip obstruction. See FIG. 1 on page 10 for part references.

Shutdown

Daily Shutdown



NOTICE

Failure to perform this procedure correctly and according to the prescribed schedule can result in poor mixing, fluid leaking, and cured material in or on the gun.

1. Perform **Pressure Relief Procedure**.
2. Solvent flush at 80-100 psi (550-700 kPa, 5.5-7.0 bar) for five seconds.

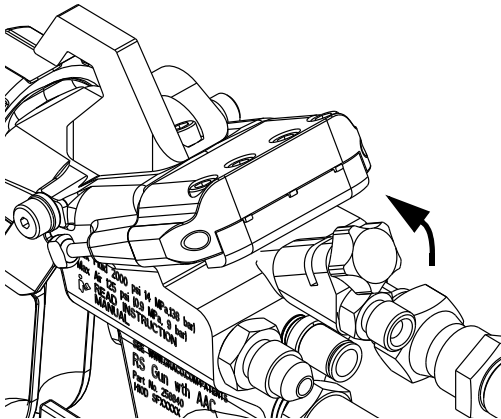

3. Loosen then remove air cap retaining ring.

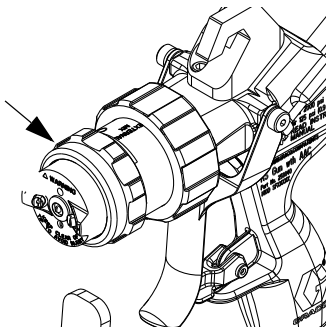

4. For internal mix guns, remove mixing element.

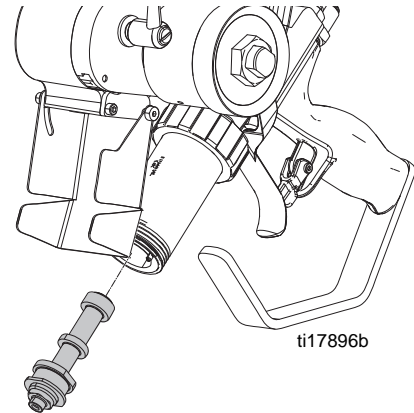

5. Remove front head.

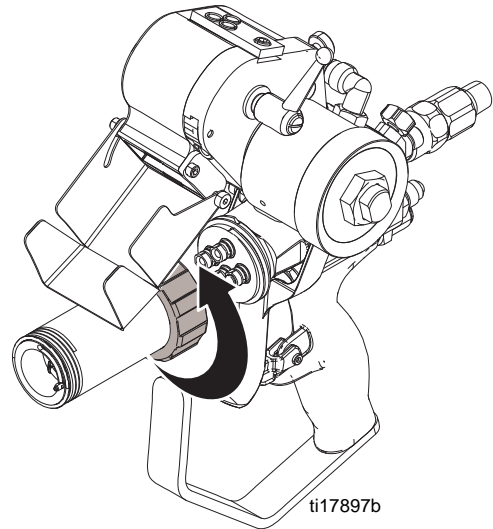

6. Immerse front head, front cap, and the mixing element (internal mix guns only) in solvent. Use a sealed container to prevent solvent evaporation.

NOTICE

Immersing the cutter assembly in solvent will damage it and void the warranty.

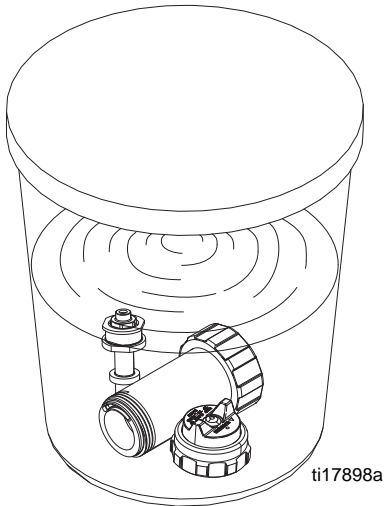

ti17898a

NOTICE

In the following step, do not rinse catalyzed solvent over the resin port. This may result in cured material.

7. Rinse front face of gun with clean solvent. Use a squirt bottle or paint brush dipped in clean solvent.

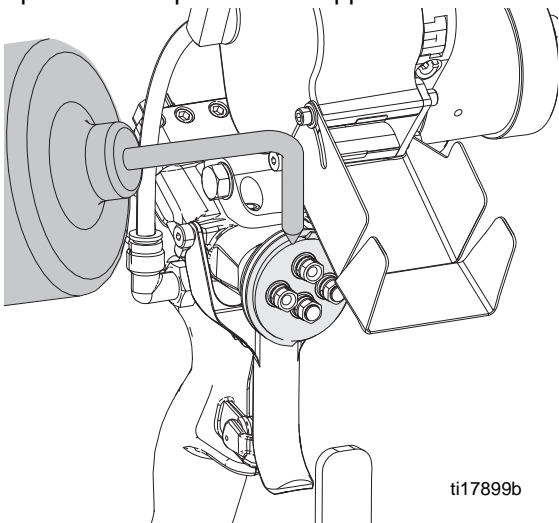

ti17899b

8. Rinse excess resin from the resin port.

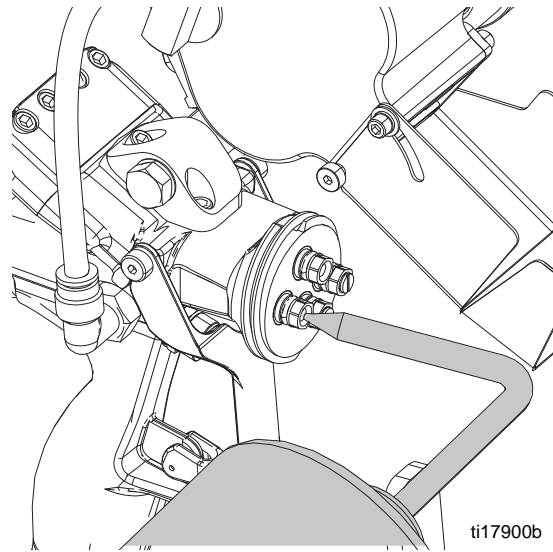

ti17900b

9. Lubricate the gun front face and check valve ports with grease (Part No. 118665) as shown in the following illustration.

NOTICE

To prevent catalyst fumes from mixing with resin resulting in cured material, make sure to put grease in the resin port.

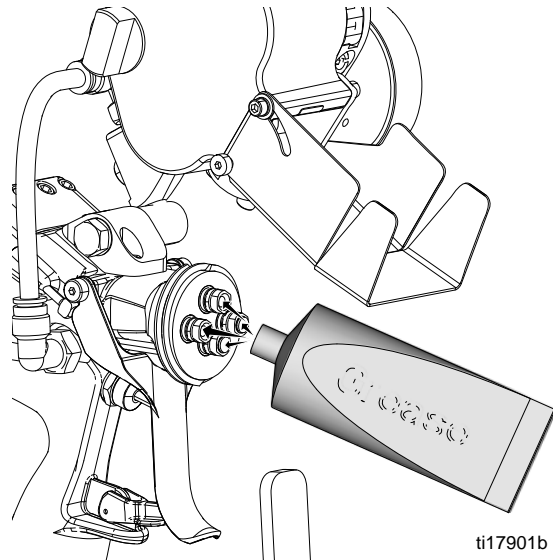

ti17901b

NOTICE

Failure to clean the surface between the trigger clamp and the gun body can lead to material buildup preventing the clamp from seating properly resulting in material leakage from the front of the gun.

10. Wipe the trigger clamp assembly, actuator pins, and surface between the trigger clamp and the gun body with a rag to remove material. Use a compatible solvent.

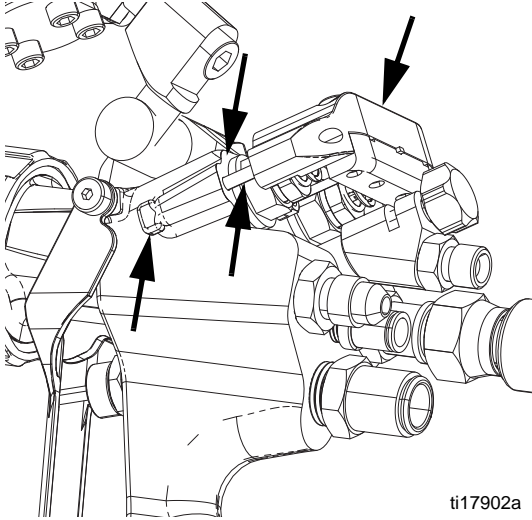

Long-Term Shutdown

If gun will be unused for at least one week, perform this long-term shutdown procedure.

1. Perform **Daily Shutdown** procedure, beginning on page 21.
2. **Flush System**, see page 24.

Maintenance

Flush System

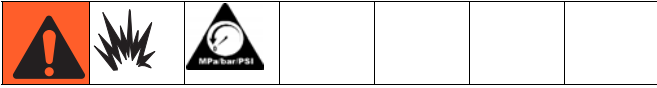

NOTE:

- Flush before changing colors, before fluid can dry in the equipment, before storing, and before repairing equipment.
- Flush at the lowest pressure possible. Check connectors for leaks and tighten as necessary.
- Flush with a fluid that is compatible with the fluid being dispensed and the equipment wetted parts.

NOTICE

Immersing the cutter assembly in solvent will damage it and void the warranty.

1. Follow **Pressure Relief Procedure**, page 20.
2. Remove front head from gun and soak in solvent.
3. Place siphon tube in grounded metal pail containing solvent.
4. Set pump to lowest possible fluid pressure then start pump.

NOTE: The recommended solvent pressure during flushing is 80-100 psi (550-700 kPa, 5.5-7.0 bar).

5. Hold a metal part of the gun firmly to a grounded metal pail. Trigger the gun until clean solvent dispenses.
6. Perform **Pressure Relief Procedure**, page 20.
7. Remove gun from hose.

Troubleshooting

See the troubleshooting procedures beginning on page 29 for additional troubleshooting help.



Problem	Cause	Solution
Catalyst leaking	Trigger clamp assembly slipped	See Fluid Leaking from Front of Gun on page 29.
	Catalyst hose loose	Inspect and tighten
	Catalyst fitting loose	Inspect and tighten
	Locking ring loose	Clean and tighten
	Air cap catalyst post o-ring damaged or missing	Inspect and replace if necessary
	Catalyst check valve housing o-rings missing or damaged	Inspect and replace if necessary
	Needle assembly o-ring damaged or missing	Inspect and replace if necessary
	Needle packing loose	See Fluid Leaking from Under Trigger Clamp Assembly on page 30
	Valve seat worn or damaged	Inspect and replace if necessary
	Valve seat seal damaged	Inspect and replace if necessary
Resin leaking	Trigger clamp assembly slipped or misaligned	See Fluid Leaking from Front of Gun on page 29.
	Resin hose loose	Inspect and tighten
	Resin fitting loose	Inspect and tighten
	Locking ring loose	Clean and tighten
	Air cap catalyst post o-ring damaged or missing	Inspect and replace if necessary
	Resin check valve housing o-rings missing or damaged	Inspect and replace if necessary
	Needle assembly o-ring damaged or missing	Inspect and replace if necessary
	Needle packing loose	See Fluid Leaking from Under Trigger Clamp Assembly on page 30
	Valve seat worn or damaged	Inspect and replace if necessary
	Valve seat seal damaged	Inspect and replace if necessary

Problem	Cause	Solution
Gun does not fully actuate when triggered	Trigger clamp not opening properly	Perform Adjust Trigger Clamp procedure on page 29
	Safety lock engaged	Disengage safety lock
	Trigger clamp pins bent	Inspect and replace if necessary
	Cutter air valve stuck	Inspect and replace if necessary
	Overspray on trigger clamp pins	Clean and lubricate
	Needle assembly stuck	Check and adjust needle packing tension, see Adjust Needle Packing Tension on page 30
	Hardened material in the needle/seat area	Remove needle assembly, clean and replace if necessary
Fluid does not spray when trigger is fully actuated	Proportioner off or in bypass mode	Turn on proportioner and make ready to spray
	Worn trigger clamp pins	Inspect and replace if necessary
	Worn trigger	Inspect and replace if necessary
	Loose trigger clamp assembly	Inspect and torque as specified, see Adjust Trigger Clamp on page 29
	Misadjusted or missing actuator pin adjustment screws	If missing, replace screws. If misadjusted, see Adjust Actuator Pin Adjustment Screws , page 31.
	Hardened material in front head (passage-way and spray tip)	Check for blockage, perform Remove Hardened Material from Internal Mix Front Head on page 32 as necessary.
	Hardened material in the needle/seat area	Remove needle assembly, clean and replace if necessary
Resin is present but NO catalyst	No catalyst	Check catalyst fluid level
	Catalyst pump in bypass	Turn on and make ready to spray
	Trigger clamp out of phase	1) Adjust Trigger Clamp , page 29 2) Adjust Actuator Pin Adjustment Screws , page 31
	Actuator pin adjustment screw missing	Replace then perform Adjust Actuator Pin Adjustment Screws , page 31
	Trigger worn	Inspect and replace if necessary
	Actuator pin worn	Inspect and replace if necessary
	Trigger clamp assembly loose	Inspect and torque as specified, see Adjust Trigger Clamp on page 29
	Catalyst check valve stuck closed	Inspect and replace if necessary
	Hardened material in the needle/seat area	Remove needle assembly, clean and replace if necessary

Problem	Cause	Solution
Catalyst is present but no resin	No resin	Check material fluid level
	Trigger clamp out of phase	1) Adjust Trigger Clamp , page 29 2) Adjust Actuator Pin Adjustment Screws , page 31
	Catalyst pump in bypass	Turn on and make ready to spray
	Actuator adjustment screw missing	Replace then perform Adjust Actuator Pin Adjustment Screws , page 31
	Trigger worn	Inspect and replace if necessary
	Actuator pin worn	Inspect and replace if necessary
	Trigger clamp assembly loose	Inspect and torque as specified, see Adjust Trigger Clamp on page 29
	Hardened material in the needle/seat area	Remove needle assembly, clean and replace if necessary
Catalyst pressure drops on initial trigger	Trigger clamp not opening evenly	1) Adjust Trigger Clamp , page 29 2) Adjust Actuator Pin Adjustment Screws , page 31
Material continues to spray after trigger is released	Foreign object under trigger clamp	Clean and replace if necessary
	Overspray on trigger clamp pins	Clean and lubricate
	Actuator pins sticking	Clean and replace if necessary
	Needle packing too tight	Check and adjust needle packing tension, see Adjust Needle Packing Tension on page 30
Material spraying out AAC ports	Retaining ring not tight	Tighten retaining ring
	Cut or missing internal mix diffuser o-ring	Inspect and replace if necessary
	Cut or missing external mix check valve o-ring	Inspect and replace if necessary
	Internal mix check valve seat missing or damaged or not tight	Inspect and replace if necessary
	External mix check valve seat missing or damaged or not tight	Inspect and replace if necessary
Material not mixed	External mix catalyst tips plugged	Clean and replace
	Atomizing air pressure too low	Adjust
	Static mixer missing	Replace, see Replace Internal Mix Element on page 34.
	Static mixer worn	Inspect and replace if necessary, see Replace Internal Mix Element on page 34.
	Incorrect static mixer	Replace if necessary, see Replace Internal Mix Element on page 34.
AAC does not function	Air supply to gun is shut off	Open air supply
	Air regulator set incorrectly	Adjust
	Ports plugged	Clean air capped or replace
	AAC needle valve closed (external mix)	Open AAC needle valve
	Trigger clamp assembly loose	Adjust Trigger Clamp , page 29

Problem	Cause	Solution
No solvent	Not enough solvent pressure	Increase solvent pressure to the recommended range of 80-100 psi (550-700 kPa, 5.5-7.0 bar).
	No fluid in pressure pot	Refill pressure pot
	Output valve closed	Open output valve
	Check valve stuck closed	Increase pressure in pressure pot
	Material check valve plugged	Clean and replace as needed
	Solvent needle valve closed	Open solvent needle valve
	Solvent check valve stuck closed	Ensure the solvent check valve opens freely
Solvent in catalyst/resin mix	Solvent needle valve open	Close solvent needle valve
	Solvent check valve o-ring damaged or missing	Inspect and replace if necessary
	Solvent valve damaged	Inspect and replace if necessary
Resin in solvent line	Solvent needle valve open	Close solvent needle valve
	Solvent check valve o-ring damaged or missing	Inspect and replace if necessary
	Solvent valve damaged	Inspect and replace if necessary
AAC does not shut off	AAC needle o-ring damaged (internal mix)	Inspect and replace if necessary
Atomized catalyst air does not shut off	Atomized catalyst air needle o-ring damaged (external mix)	Inspect and replace if necessary
Air leakage	Air lines not fully seated in push lock tube fittings	Ensure air lines are fully seated in fitting
	Cutter assembly pivot tube o-ring damaged or missing	Inspect and replace if necessary
	AAC/Atomized catalyst external needle o-ring damaged	Inspect and replace if necessary
	Cutter air valve seat damaged	Inspect and replace if necessary
	G hook o-ring missing	Inspect and replace if necessary
	Cutter mount o-ring missing	Inspect and replace if necessary

Fluid Leaking from Front of Gun

						
To prevent skin injection, never use a gun that has a resin and/or catalyst leakage.						

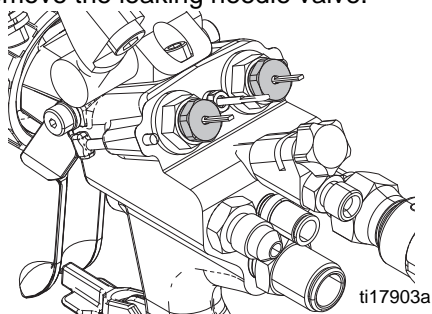

Perform this procedure to find the source of the leakage and to stop the leak.

1. Perform **Adjust Trigger Clamp** to attempt to fix the leak.
2. If the leakage still exists:
 - a. Follow **Pressure Relief Procedure**, page 20.
 - b. Remove the leaking needle valve.



- c. Verify no obstruction between the ball and seat. Clean as necessary.
- d. If the resin side is leaking, use a 9/64 in. allen-wrench to remove the seat.
- e. If the catalyst side is leaking, use a 0.093 in. allen wrench to remove the seat.
- f. Verify the seat surface is free of wear and scratches.
- g. If wear or scratches are found on the seat, discard defective seat and replace with new seat.
- h. Install seat.
- i. Install valve.
- j. See **Adjust Trigger Clamp** on page 29 to install and adjust the trigger clamp.
- k. Install front head assembly (F).

Adjust Trigger Clamp

						
To prevent skin injection, never use a gun that has a resin and/or catalyst leakage.						

NOTICE

Failure to perform this procedure correctly and when required can result in poor mixing and fluid leaking.

Perform this procedure if there is fluid leakage from the front of the gun or if the gun is out of phase. This procedure. See FIG. 10.

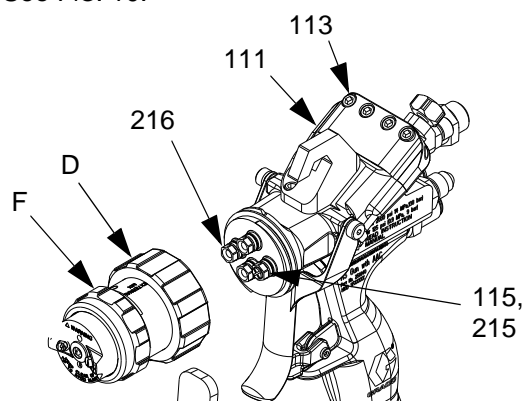

FIG. 10: External Mix shown

1. Perform **Pressure Relief Procedure**, page 20.
2. Engage trigger lock.
3. Loosen four screws (113).
4. While pressing the trigger clamp assembly (111) firmly against the gun body, tighten the four screws (113) in the following sequence:
 - a. Tighten the two inside screws to 25 in-lb (2.8 N•m).
 - b. Tighten the two outside screws to 10 in-lb (1.1 N•m).
5. Loosen front head locking ring (C) then remove front head assembly (F).
6. Pressurize the resin and catalyst fluid lines to operating pressures and verify there is no leakage.

NOTE: Do not overtighten the two outside screws as this may cause leakage.

Fluid Leaking from Under Trigger Clamp Assembly

1. Follow **Pressure Relief Procedure**, page 20.
2. Remove trigger clamp assembly (A).

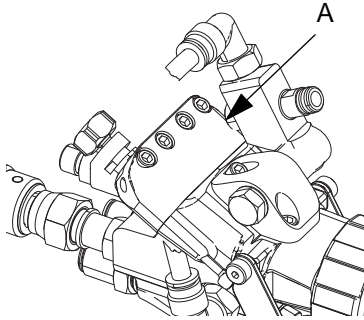

3. Tighten packing nut (906).

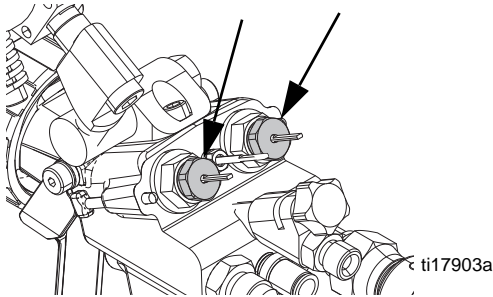

4. If the leakage stopped, see **Adjust Trigger Clamp** on page 29 to install and adjust the trigger clamp.
5. If the leakage still exists:
 - a. Disassemble the needle assembly.
 - b. Discard the packing disk (904).

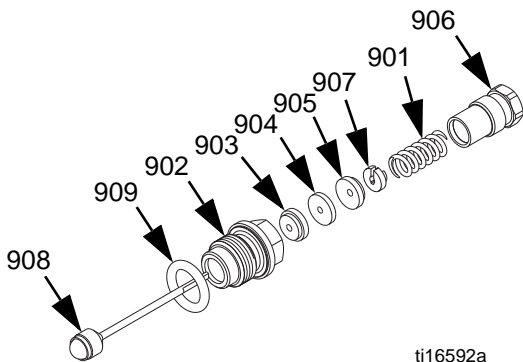

Beveled edge must face rear of needle

- c. Discard the o-ring (909) if wear or damage is found.
- d. Reassemble the needle assembly.
- e. Install the needle assembly into the gun.
- f. See **Adjust Trigger Clamp** on page 29 to install and adjust the trigger clamp.

Adjust Needle Packing Tension



If there is a fluid leak at the rear of the needle assembly, the packings can be tightened to stop the leak.

1. Follow **Pressure Relief Procedure**, page 20.
2. Loosen four screws (113) then remove trigger clamp assembly (111). See page 38.
3. Use 7/16 in. wrench to tighten packing nut (906) 1/8th of a turn.
4. Re-pressurize and re-check for leaks in rear of needle. If leak remains, packings may need to be replaced. If necessary, see **Replace Needle Packing** on page 37.
5. Ensure needle flats are aligned with one another.
6. Install trigger clamp assembly on gun then perform **Adjust Trigger Clamp** procedure on page 29.
7. Trigger gun to check for smooth operation of material needles. If material needles do not operate smoothly, packings may need to be replaced.

NOTICE

Be careful not to overtighten trigger clamp assembly as this will cause the material needles to bind and cause material needles to operate incorrectly.

Adjust Actuator Pin Adjustment Screws



Perform this procedure if the trigger clamp pulls away from the gun body unevenly when the trigger is pulled, see FIG. 12. This procedure adjusts the actuator pins (111) in the trigger clamp, see FIG. 11.

When the trigger is pulled, it moves the trigger clamp assembly resulting in fluid flow from each component.

NOTE: The actuator pins are factory set. If the trigger, trigger clamp assembly, or pins are removed the trigger may need to be adjusted.

NOTE: When installing the four finger trigger (16F627), ensure trigger lock functions and clamp assembly opens correctly, see FIG. 12. If any adjustments are needed perform this **Adjust Actuator Pin Adjustment Screws** procedure.

1. Perform **Pressure Relief Procedure**, page 20.
2. Engage trigger lock.
3. Use 5/64 in. allen key to remove adjustment screws (114).

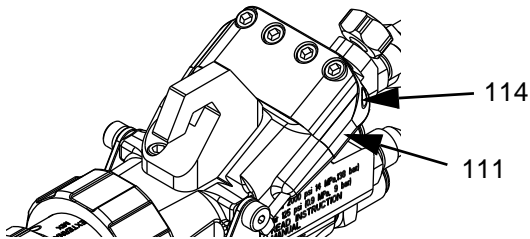

FIG. 11

4. Apply medium strength thread sealant to threads of screws.
5. Install adjustment screws (114) into trigger clamp assembly (111).
6. Squeeze trigger so that it touches the trigger lock. If trigger cannot touch trigger lock, back out adjustment screws until trigger touches the trigger lock.

7. Adjust each screw until the actuator pin just begins to touch the trigger. This can be verified by the trigger just beginning to lift off of the trigger lock.
8. Back each screw out 1/2 turn.
9. Disengage trigger lock.
10. While watching the trigger clamp assembly, trigger the gun to verify both sides of the trigger clamp assembly pull away from the gun body at the same time.

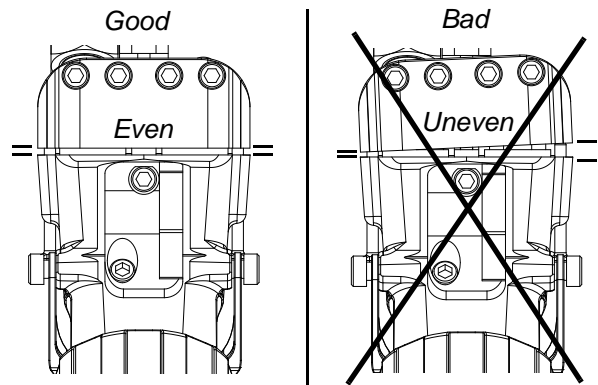

FIG. 12

11. Hold the trigger fully engaged and measure the space between the trigger clamp and the gun body on both sides. The gaps should be at least 0.065 in. (1.65 mm) in the open position. Adjust screws as necessary. See FIG. 12.

Repair

Remove Hardened Material from Internal Mix Front Head

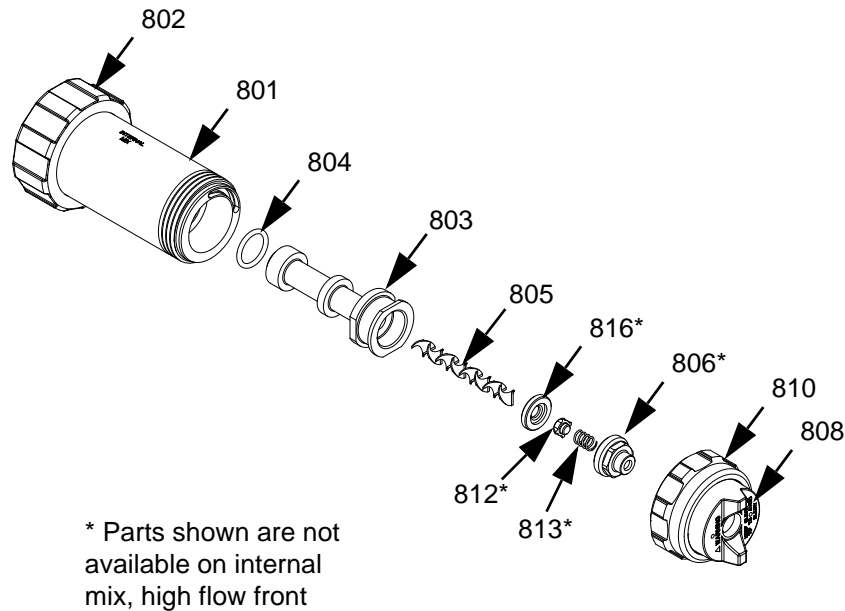

FIG. 13

Perform this procedure when the internal mix diffuser assembly is filled with cured material. When this happens, the diffuser assembly must be drilled out.

1. Perform **Pressure Relief Procedure**, page 20.
2. Loosen then remove retaining ring (810) and air cap assembly (808) from head (801).
3. Remove diffuser assembly (803).
4. Use two wrenches on flats of diffuser and cap (806) to remove cap.
5. Use punch to break the check valve (812) and valve seat (816) loose from the hardened material. Discard the valve seat and spring (813).
6. Use punch to break hardened material loose from the diffuser cap (806).

7. For standard 1/4 in. mixers, use a 0.152 in. drill in the diffuser assembly outlet to remove hardened material.
For high flow 3/8 in. mixers, use a 0.161 in. drill.

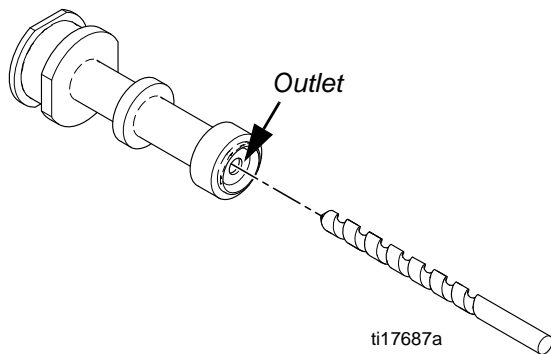

FIG. 14

8. For 1/4 in. mixers, use a 0.246 in. drill in the diffuser assembly inlet to remove hardened material.
For 3/8 in. mixers, use a 0.359 in. drill.

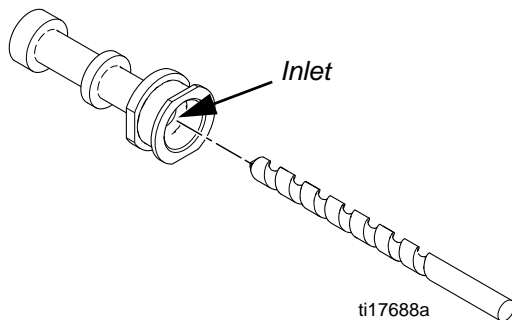

FIG. 15

9. Use a pick to remove any cured material from the front air cap (808).
10. Install new mix element into diffuser (803).
11. Install new check valve seat (816) into diffuser. See FIG. 16 for seat orientation.

12. Install check valve (812) and new spring (813) into the seat then install cap (806). See FIG. 18 for orientation of parts.

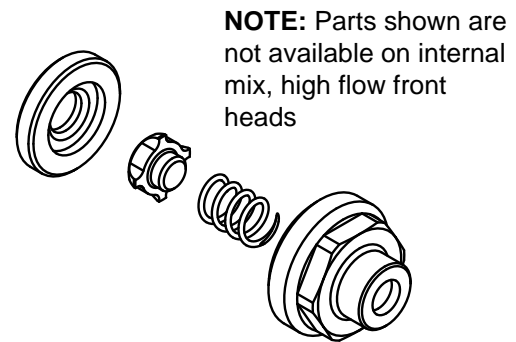

FIG. 16

13. Remove and inspect o-ring (804). Replace if worn or damaged.
14. Lubricate o-ring and install onto diffuser. Install diffuser into head.
15. Torque cap to 23-27 in-lb (2.6-3.1 N•m).
16. Install diffuser into head (801).
17. Install air cap assembly and tighten retaining ring.

Replace Internal Mix Element

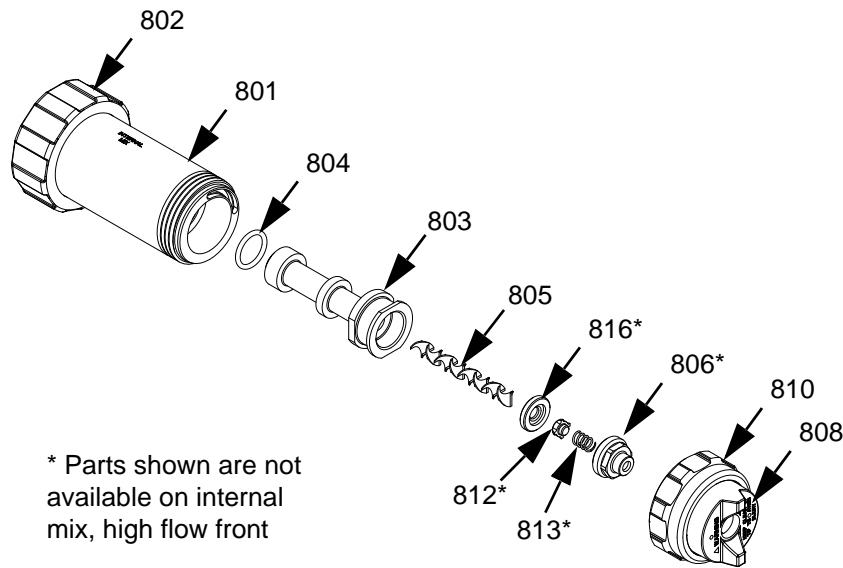

FIG. 17

See internal mix front head parts list on page 50 for available kits.

NOTICE

There is a half-moon pin pressed into the front head (801) behind the diffuser assembly (803). Do not attempt to remove this pin. Removal will result in poor mixing.

1. Perform **Pressure Relief Procedure**, page 20.
2. Remove retaining ring (810) and air cap assembly (808) from head (801).
3. Remove diffuser assembly (803).
4. Use two wrenches on flats of diffuser and cap (806) to remove cap. Spring (813) and check valve (812) will fall out when cap is removed.
5. Use a small hex key in the small hole in the back of the diffuser to push the mix element (805) and check valve seat (816) out.
6. Install new mix element into diffuser (803).
7. Install check valve seat (816) into diffuser. See FIG. 17 for seat orientation.

8. Install check valve (812) and spring (813) into the seat then install cap (806). See FIG. 18 for orientation of parts.

NOTE: Parts shown are not available on internal mix, high flow front heads

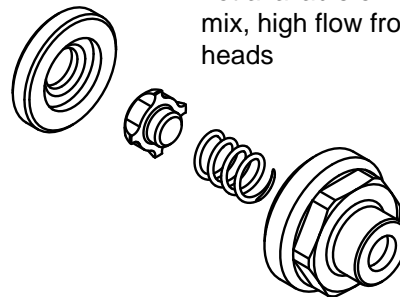

FIG. 18

9. Remove and inspect o-ring (804). Replace if worn or damaged.
10. Lubricate o-ring and install onto diffuser. Install diffuser into head.
11. Torque cap to 23-27 in-lb (2.6-3.1 N•m).
12. Install diffuser into head (801).
13. Install air cap assembly and tighten retaining ring.

Replace External Mix Check Valve and O-Rings

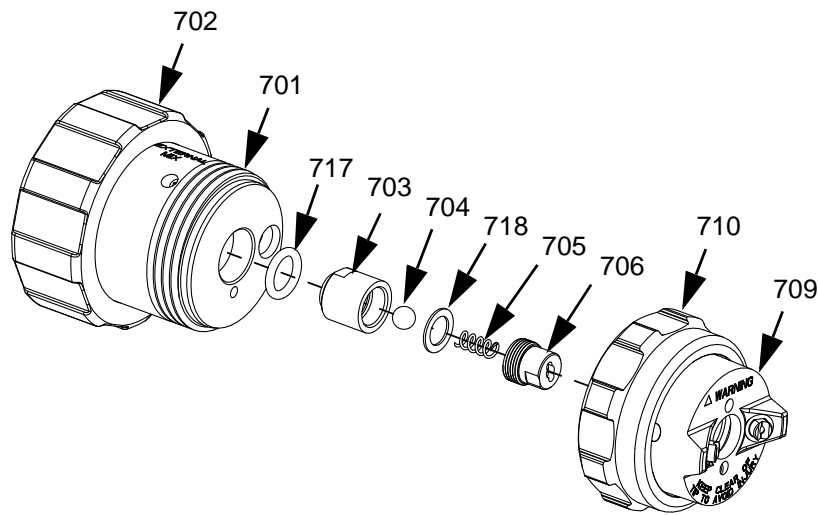

FIG. 19

See **Front Head Assemblies** beginning on page 49 for available kits.

1. Perform **Pressure Relief Procedure**, page 20.
2. Remove retaining ring (710) and air cap assembly (709) from head (701).
3. Remove check valve assembly (703).
4. Use two wrenches on flats of seal (703) and check valve cap (706) to remove cap. Spring (705) and ball (704) will fall out when cap is removed.
5. Remove and inspect o-ring (717) and washer (718). Replace if worn or damaged.
6. Lubricate o-ring and install onto check valve assembly (703).
7. Install washer (718), ball (704), and spring (705) into check valve seal (703) then install check valve cap (706) onto check valve seal finger-tight.
8. Use two wrenches on flats of seal (703) and check valve cap (706) to torque check valve cap onto check valve seal to 23-27 in-lb (2.6-3.1 N•m).
9. Install check valve assembly into head. See FIG. 19 for assembly orientation.

10. Install air cap onto head and tighten retaining ring (710).

NOTICE

To prevent distorting the end of the cap (706), do not over-tighten the check valve assembly.

Replace Material Needle Assembly



NOTE: The material needle assemblies are the two side needles (105) in the rear of the gun. See page 38.

1. Follow **Pressure Relief Procedure**, page 20.
2. Loosen four screws (113) then remove trigger clamp assembly (111). See page 38.
3. Use 1/2 in. deep well socket to break loose and remove material needle assemblies.
4. Install new material needle assemblies.
5. Ensure needle flats are aligned with one another.
6. Install trigger clamp assembly on gun then perform **Adjust Trigger Clamp** procedure on page 29.

NOTICE

Be careful not to overtighten trigger clamp assembly as this will cause the material needles to bind and cause material needles to operate incorrectly.

Replace Center Needle Assembly



1. Follow **Pressure Relief Procedure**, page 20.
2. Loosen four screws (113) then remove trigger clamp assembly (111). See page 38.
3. Use 7/32 in. deep well socket to remove retainer (108) then remove the needle (106), spring (107), and o-ring (110).
4. Install new o-ring. Verify needle is clean before re-installing. Use a liberal amount of lubrication.
5. Install rear packing retainer with a liberal amount of lubrication.

Replace Needle Packing



NOTE: The needle packing is the seal (904) inside the needle assembly (105). See pages 38 and 52.

NOTICE

Needles bend easily. To prevent bending and damaging the needles, be careful when using wrenches to remove the needle packings.

1. Follow **Pressure Relief Procedure**, page 20.
2. Use 9/64 in. hex key to loosen the four screws (114) on trigger clamp (111). Remove clamp. See page 38.
3. Use 7/16 in. wrench to break loose then remove the packing nuts (906). See page 52.
4. Remove needle (908).
5. Remove old packing from needle.
6. Liberally lubricate the new packing with grease (Part No. 118665).
7. Install new packing onto needle. Install packing with beveled edge facing rear of needle.

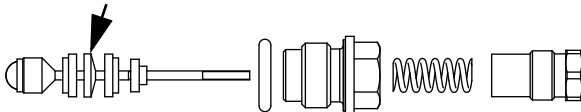

8. Install needle.
9. Install packing nuts and torque to 30 in-lb (3.4 N•m).
10. Ensure needle flats are aligned with one another.
11. Slide trigger clamp onto gun then, with the trigger clamp loose, perform **Adjust Trigger Clamp** procedure on page 29.

NOTICE

Be careful not to overtighten trigger clamp assembly as this will cause the material needles to bind and cause material needles to operate incorrectly.

Ref	Part	Description	Qty	Ref	Part	Description	Qty
				139	16C279	BODY, gel gun mount	1
100	199360	DOCUMENT, declaration	1	141	123909	SCREW, cap, sh	2
101	24N711	HANDLE, gun	1	143	124282	SCREW, set	1
102†‡	24E428	SEAL, needle, seat (pack of 6)	2	148	24F007	KIT, tool, hex keys, gun	1
103‡	16C104	RETAINER, seat, needle valve, resin	1	152	126395	SCREW, set, flat point	1
	24M833 P	OPTIONAL - RETAINER, seat, needle valve, resin, carbide		153★	16D039	RESTRICTOR, catalyst	1
104†	24D201	RETAINER, seat, catalyst	1	154▲	222385	TAG, skin injection warning and note to physician	1
105**	24E417	NEEDLE, assembly	2	155	CST521	TIP, spray, 521	1
106*	16C101	NEEDLE, aac	1	158▲	16P319	LABEL, quick start, RS gun	1
107*	123633	SPRING, needle assembly	1	159	295662	PLUG, pipe	1
108*	16C100	RETAINER, aac	1	160	189018	SWIVEL	1
109*	24E429	O-RING (pack of 6)	1	* Parts included in Solvent/AAC assembly kit 24E415.			
110*	24E430	O-RING (pack of 6)	1	† Parts included in catalyst seat kit 24E420.			
111◆	16C098	CLAMP, trigger, top	1	‡ Parts included in resin seat kit 24E421.			
112◆	16C099	CLAMP, trigger, bottom	1	◆ Parts included in needle clamp kit 24E416.			
113◆	124057	SCREW, cap, sh	4	* Parts included in AAC needle kit 24E419.			
114◆	GC2082	SCREW, set, flpt	2	★ Parts included in catalyst fitting kit 24H269.			
115❖	24E423	HOUSING, check valve asm, catalyst	1	❖ Parts included in gun trigger kit 24H268.			
115a	123934	O-RING, FKM (smaller o-ring in housing)	1	** Kit 24E436 includes 6 needle assemblies.			
115b	112319	O-RING (larger o-rings on outside of housing)	2	❖ O-rings on housings are available in kit 257425.			
116❖	24E424	HOUSING	3	▲ Replacement Danger and Warning labels, tags, and cards are available at no cost.			
116a	112319	O-RING	6	P Parts included in Carbide resin seat kit 16N889			
117	24E427	HEAD, asm, ext mix, vert	1				
118	16C705	PLUG, trigger	1				
119	111316	PACKING, o-ring	1				
120❖	179737	PIN, actuator	2				
121❖	16C085	TRIGGER, gun, 2-finger	1				
121a	16F627	TRIGGER, 4-finger (not shown)	1				
122❖	123733	BOLT, shoulder, self locking	2				
123	276745	STOP, trigger	1				
124	112033	PIN, dowel	1				
125	16C130	GUARD, trigger	1				
126	111945	SCREW, cap, fl hd	2				
127	16C107	FITTING, resin hose	1				
128*	16C118	FITTING, solvent	1				
129*	16C117	VALVE, solvent	1				
130*	24E437	PACKING, o-ring (pack of 6)	1				
131*	24E431	O-RING (pack of 6)	1				
132*	24E432	RING, retaining, e-ring (pack of 6)	1				
133*	16C119	FITTING, insert, solvent	1				
134*	111450	PACKING, o-ring	2				
135	123737	FITTING, tube, push connector	1				
136	123736	FITTING, tube, push connector	1				
138★	16C108	FITTING, catalyst hose	1				

Internal Mix Gel Gun, 258853

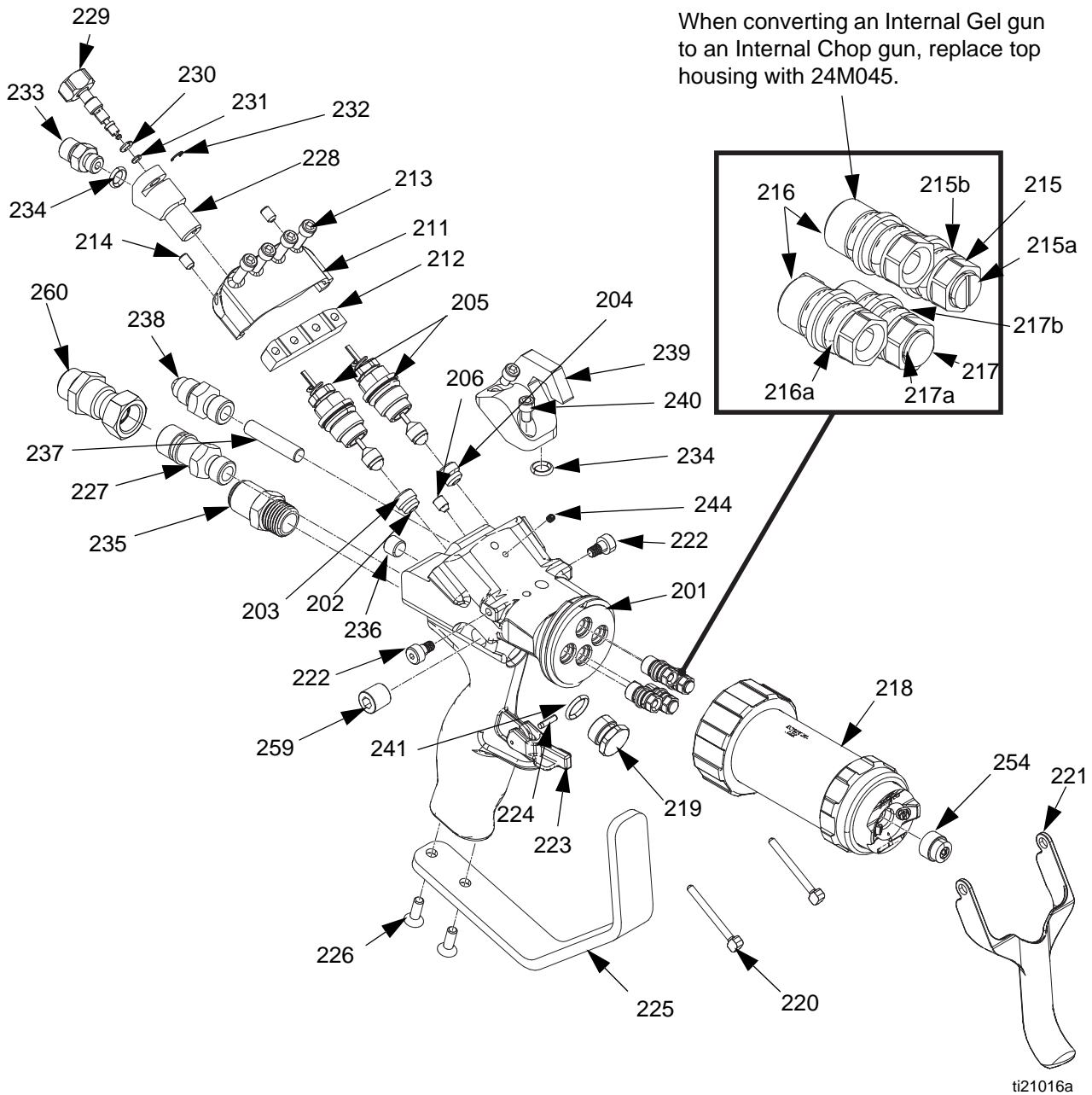

ti21016a

Ref	Part	Description	Qty	Ref	Part	Description	Qty
				237★	16D039	RESTRICTOR, catalyst	1
200	199360	DOCUMENT, declaration	1	238★	16C108	FITTING, catalyst hose	1
201	24N711	HANDLE, gun	1	239	16C279	BODY, gel gun mount	1
202†‡	24E428	SEAL, needle, seat (pack of 6)	2	240	123909	SCREW, cap, sh	2
203‡	16C104	RETAINER, seat, needle valve, resin	1	241	111316	PACKING, o-ring	1
	24M833 P	OPTIONAL - RETAINER, seat, needle valve, resin, carbide		244	124282	SCREW, set	1
204†	24D201	RETAINER, seat, catalyst	1	249	24F007	KIT, tool, hex keys, gun	1
205**	24E417	NEEDLE, assembly	2	254	CST521	TIP, spray, 521	1
206	GC2241	SCREW, set	1	257▲	222385	TAG, skin injection warning and note to physician	1
211◆	16C098	CLAMP, trigger, top	1	258▲	16P319	LABEL, quick start, RS Gun	1
212◆	16C099	CLAMP, trigger, bottom	1	259	295662	PLUG, pipe	1
213◆	124057	SCREW, cap, sh	4	260	189018	SWIVEL	1
214◆	GC2082	SCREW, set, flpt	2	* Parts included in Solvent/AAC assembly kit 24E415.			
215❖	24G764	HOUSING, check valve asm, catalyst	1	† Parts included in catalyst seat kit 24E420.			
215a	123934	O-RING, FKM (smaller o-ring in housing)	1	‡ Parts included in resin seat kit 24E421.			
215b	112319	O-RING (larger o-rings on outside of housing)	2	◆ Parts included in needle clamp kit 24E416.			
216❖	24E424	HOUSING	2	★ Parts included in catalyst fitting kit 24H269.			
216a	112319	O-RING	6	❁ Parts included in gun trigger kit 24H268.			
217❖	24H270	HOUSING, check valve asm, solvent	1	❖ O-rings on housings are available in kit 257425.			
217a	123934	O-RING, FKM (smaller o-ring in housing)	1	** Kit 24E436 includes 6 needle assemblies.			
217b	112319	O-RING (larger o-rings on outside of housing)	2	▲ Replacement Danger and Warning labels, tags, and cards are available at no cost.			
218	24G615	HEAD, asm, internal mix, gel	1	P Parts included in carbide resin seat kit 16N889			
219	16C705	PLUG, trigger	1				
220❁	179737	PIN, actuator	2				
221❁	16C085	TRIGGER, gun, 2-finger	1				
221a	16F627	TRIGGER, 4-finger (not shown)	1				
222❁	123733	BOLT, shoulder, self locking	2				
223	276745	STOP, trigger	1				
224	112033	PIN, dowel	1				
225	16C130	GUARD, trigger	1				
226	111945	SCREW, cap, fl hd	2				
227	16C107	FITTING, resin hose	1				
228*	16C118	FITTING, solvent	1				
229*	16C117	VALVE, solvent	1				
230*	24E437	PACKING, o-ring (pack of 6)	1				
231*	24E431	O-RING (pack of 6)	1				
232*	24E432	RING, retaining, e-ring (pack of 6)	1				
233*	16C119	FITTING, insert, solvent	1				
234*	111450	PACKING, o-ring	2				
235	123737	FITTING, tube, push connector	1				
236	116134	PLUG, pipe, headless	1				

External Mix Chop Gun with Cutter, 258970

Ref Part	Description	Qty
301 258852	GUN, external mix, chop	1
302 24E512	CUTTER ASSEMBLY, external mix	1
303 16P320	LABEL, quick start, RS gun	1

Internal Mix Chop Gun with Cutter, 258971

Ref Part	Description	Qty
401 258854	GUN, internal mix, chop	1
402 24P681	CUTTER ASSEMBLY, internal mix	1
303 16P320	LABEL, quick start, RS gun	1

Internal Mix, High Flow, Chop Gun with Cutter, 24P435

Ref Part	Description	Qty
501 24P436	GUN, internal mix, chop, high flow	1
402 24P681	CUTTER ASSEMBLY, internal mix	1
303 16P320	LABEL, quick start, RS gun	1

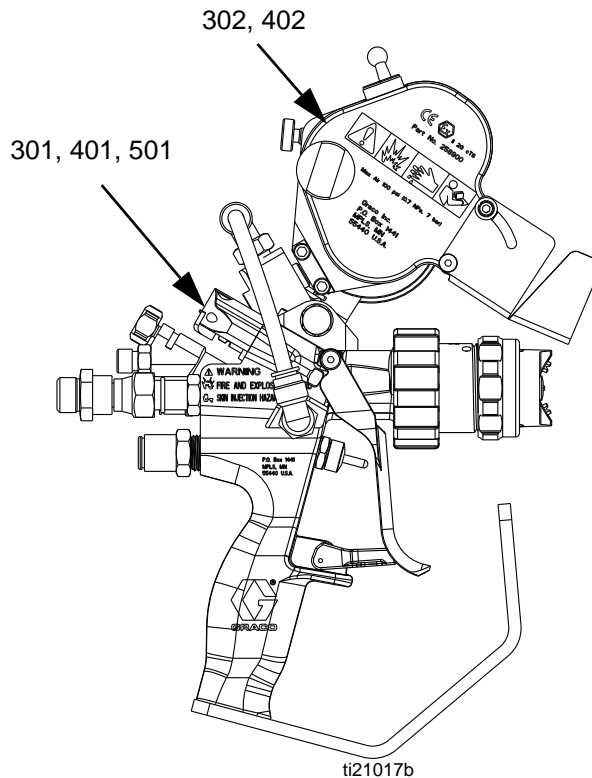

External Mix Chop Gun shown

Chop Guns

External Mix Chop Gun, 258852

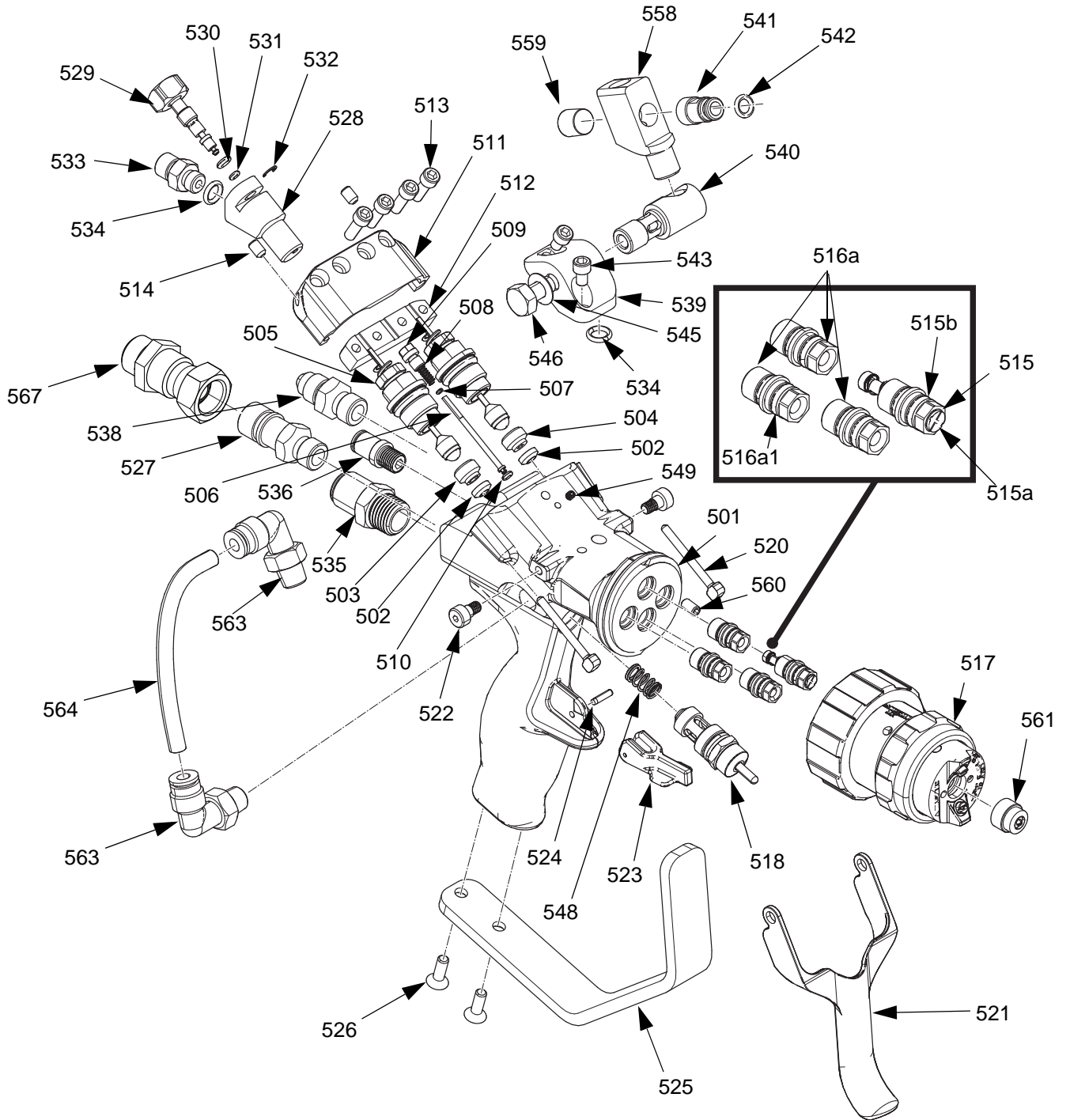

ti17943b

Internal Mix Chop Gun, 258854

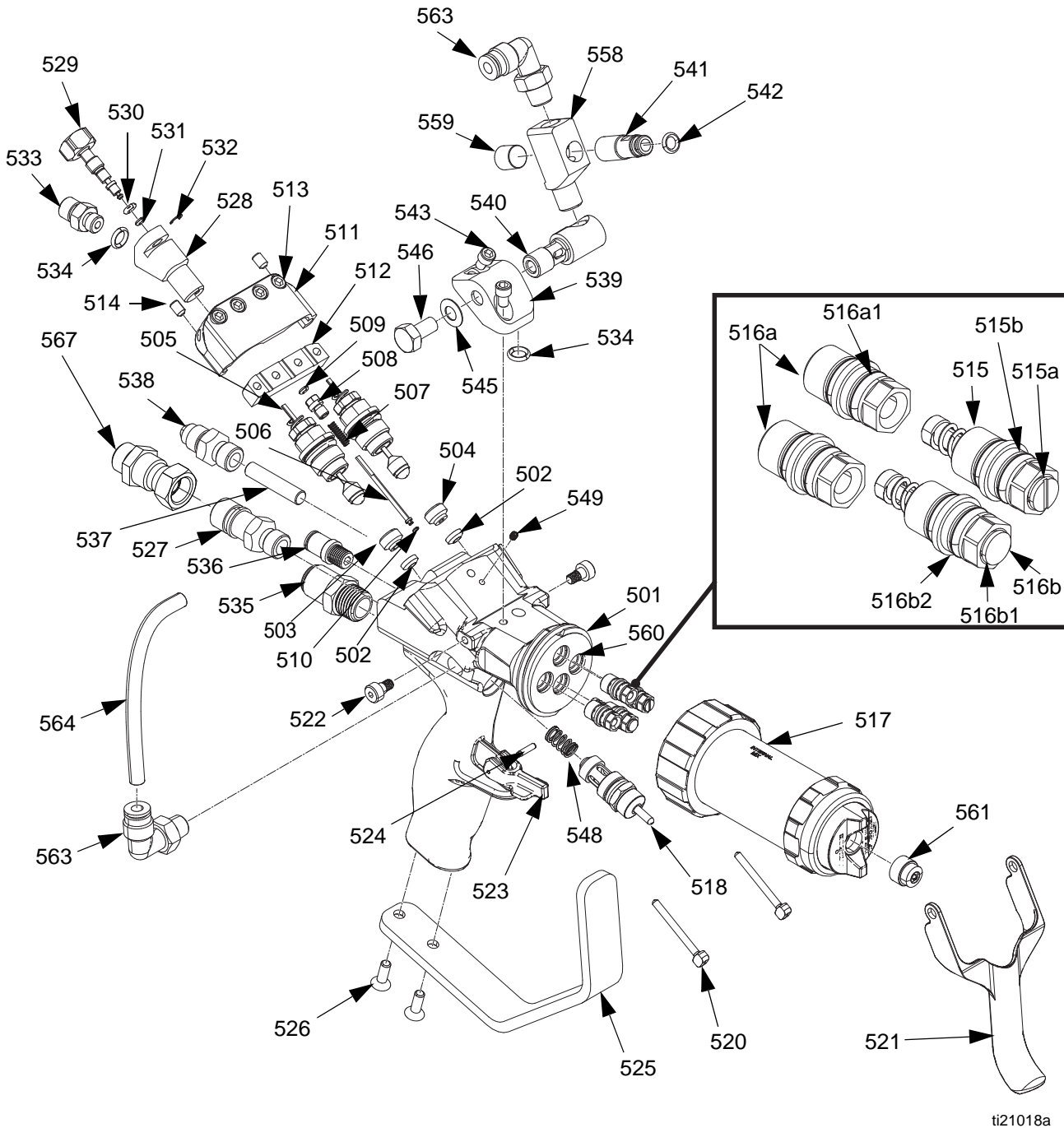

ti21018a

High Flow Internal Mix Chop Gun, 24P436

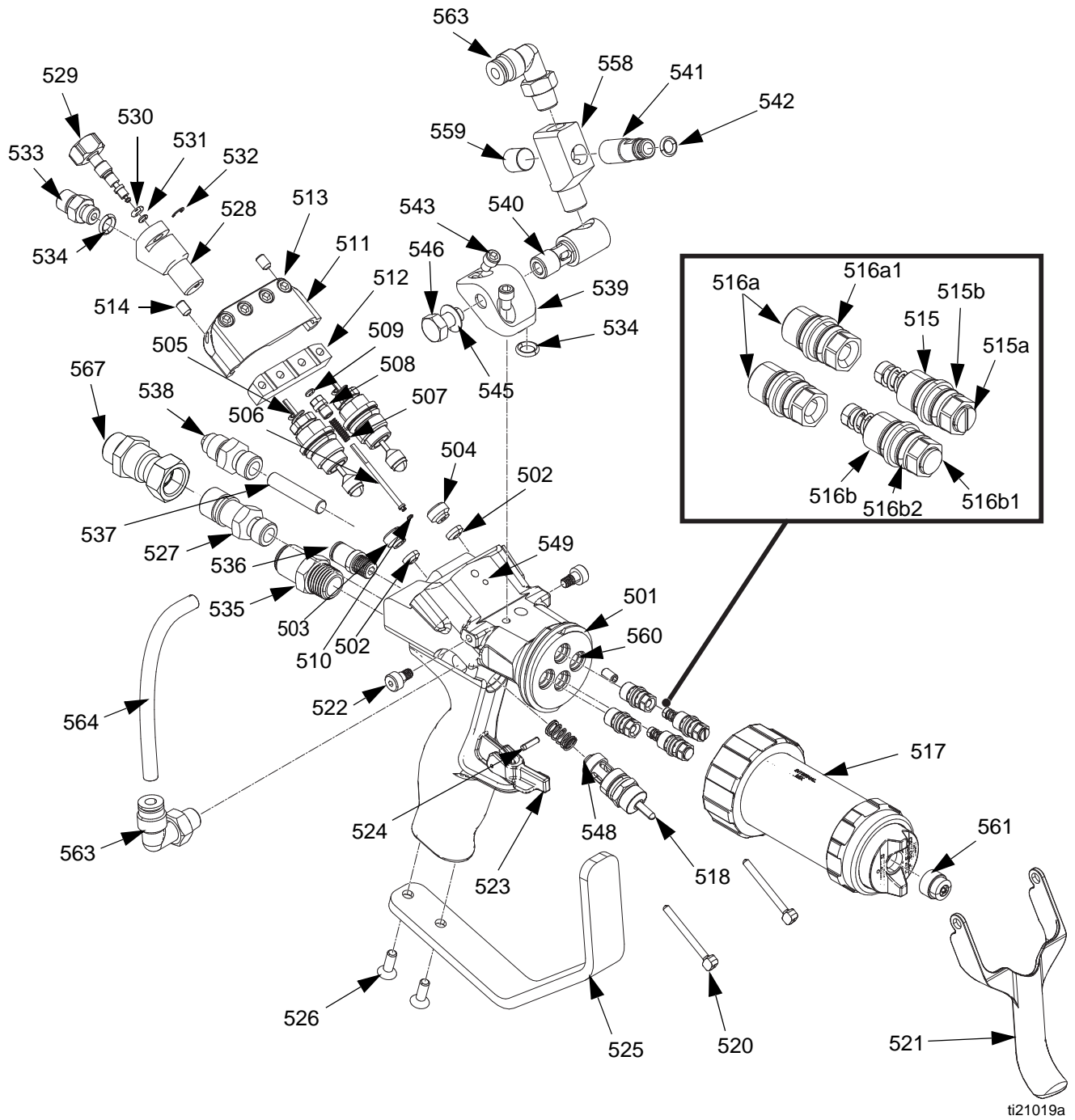

External Mix, Internal Mix, and Internal Mix High Flow Chop Gun Parts

Ref	Part	Description	Quantity		
			258852	258854	24P436
500	199360	DOCUMENT, declaration	1	1	1
501	24N711	HANDLE, gun	1	1	1
502†	24E428	SEAL, needle, seat (pack of 6)	2	2	2
503	16C104‡	RETAINER, seat, needle valve, resin	1	1	
	24M833‡	RETAINER, seat, needle valve, resin, carbide			1
505**	24E417	NEEDLE, assembly	2	2	2
506*	16C101	NEEDLE, aac	1	1	1
507*	123633	SPRING, needle assembly	1	1	1
508*	16C100	RETAINER, aac	1	1	1
509*	24E429	O-RING (pack of 6)	1	1	1
510*	24E430	O-RING (pack of 6)	1	1	1
511☼	16C098	CLAMP, trigger, top	1	1	1
512☼	16C099	CLAMP, trigger, bottom	1	1	1
513☼	124057	SCREW, cap, sh	4	4	4
514☼	GC2082	SCREW, set, flpt	2	2	2
515☼	24G764	HOUSING, check valve, catalyst		1	1
	24E423	HOUSING, check valve, catalyst	1		
515a	123934	O-RING, FKM (smaller o-ring in housing)	1	1	1
515b	112319	O-RING (larger o-rings on outside of housing)	2	2	2
516a☼	24E424	HOUSING	3	2	2
516a1	112319	O-RING	1	1	1
516b☼	24H270	HOUSING, check valve asm, solvent		1	1
516b1	123934	O-RING, FKM (smaller o-ring in housing)	1	1	1
516b2	112319	O-RING (larger o-rings on outside of housing)	2	2	2
517	24E426	HEAD, external mix, horizontal	1		
	24E442	HEAD, internal mix, chop		1	
	24P562	HEAD, internal mix, chop, high flow			1
517a	123934	O-RING, FKM (smaller o-ring in housing)	1	1	1
517b	112319	O-RING (larger o-rings on outside of housing)	2	2	2
518	24E425	VALVE, air, assy, trigger	1	1	1
520❖	179737	PIN, actuator	2	2	2
521❖	16C085	TRIGGER, gun, 2-finger	1	1	1
521a	16F627	TRIGGER, 4-finger (not shown)	1	1	1
522❖	123733	BOLT, shoulder, self locking	2	2	2
523	276745	STOP, trigger	1	1	1
524	112033	PIN, dowel	1	1	1
525	16C130	GUARD, trigger	1	1	1
526	111945	SCREW, cap, fl hd	2	2	2
527	16C107	FITTING, resin hose	1	1	1
528*	16C118	FITTING, solvent	1	1	1
529*	16C117	VALVE	1	1	1
530*	24E437	PACKING, o-ring (pack of 6)	1	1	1
531*	24E431	O-RING (pack of 6)	1	1	1
532*	24E432	RING, retaining, e-ring (pack of 6)	1	1	1
533*	16C119	FITTING, insert, solvent	1	1	1
534*◆	111450	PACKING, o-ring	2	2	2
535	123737	FITTING, tube, push connector	1	1	1
536	123736	FITTING, tube, push connector	1	1	1
537★	16D039	RESTRICTOR, catalyst		1	1
538★	16C108	FITTING, catalyst hose	1	1	1

Ref	Part	Description	Quantity		
			258852	258854	24P436
539◆	16C103	BODY, chopper mount	1	1	1
540◆	16C120	ADAPTER, chopper rotation	1	1	1
541◆	16F501	TUBE, air pivot	1		
	24F997	TUBE, air pivot		1	1
542◆	24E433	PACKING, o-ring (pack of 6)	1	1	1
543◆	123909	SCREW, cap, socket head	2	2	2
544	239663	SWIVEL, straight	1	1	1
545◆	124397	SPRING, belleville	1	1	1
546◆	C19080	SCREW, cap, hex head	1	1	1
548	124058	SPRING, compression	1	1	1
549	124282	SCREW, set, cppt	1	1	1
554	24F008	KIT, tool, hex keys, chop	1	1	1
558◆	16F500	EXTENSION, cutter	1	1	1
559◆	295662	PLUG, pipe	1	1	1
560	126395	SCREW, set, flat point	1	1	1
561	CST561	TIP, spray, 561	1	1	1
562▲	222385	TAG, skin injection warning and note to physician	1	1	1
563	125412	FITTING, elbow, male, swivel	2	2	2
564	125473	TUBE, pneumatic, polyurethane	1	1	1
567	189018	SWIVEL	1	1	1

* *Parts included in solvent/AAC assembly kit 24E415.*

† *Parts included in catalyst seat kit 24E420.*

‡ *Parts included in resin seat kit 16N899.*

✿ *Parts included in needle clamp kit 24E416.*

* *Parts included in AAC needle kit 24E419.*

** *Kit 24E436 includes 6 needle assemblies.*

★ *Parts included in catalyst fitting kit 24H269.*

❖ *Parts included in gun trigger kit 24H268.*

⊗ *O-rings on housings are available in kit 257425.*

▲ *Replacement Danger and Warning labels, tags, and cards are available at no cost.*

◆ *Parts included in **Cutter Adapter Kits**, page 48.*

Cutter Adapter Kits

External Mix Cutter Adapter Kit, 24E422 ★

Internal Mix Cutter Adapter Kit, 24G832

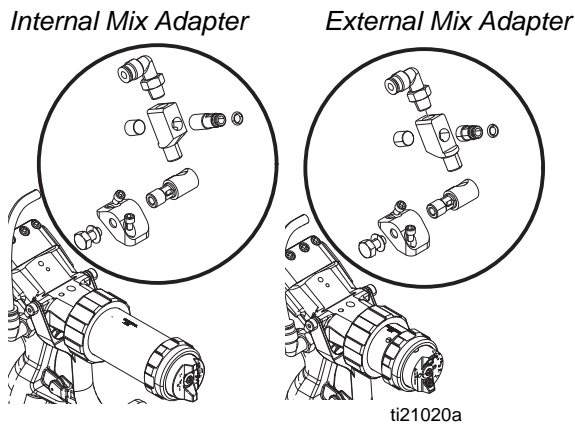

These kits provide replacement parts for the cutter adapter.

To convert an external mix gel gun to an external mix chop gun, see **External Mix Gel Gun to Chop Gun Conversion** on page 55. The internal mix gel gun cannot be converted to a chop gun.

★ For single strand, external mix chop, low pressure applications, an external mix cutter extension adapter kit may be purchased in addition to the external mix cutter adapter kit. See **External Mix Chopper Extension Kit, 24V096**, page 56.

Front Head Assemblies

External Mix Horizontal Spray Pattern Front Head, 24E426

External Mix Vertical Spray Pattern Front Head, 24E427

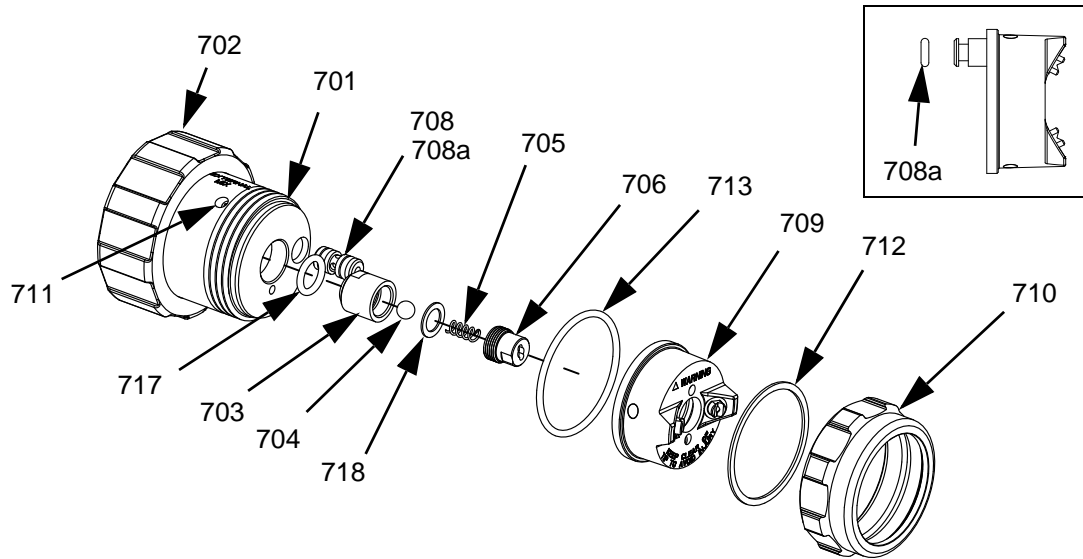

Ref	Part	Description	Qty
701	262696	HEAD, spray, external mix	1
702	16C220	RING, locking	1
703*	16C489	SEAL, tip, external mix	1
704*†	M72843	BALL, sst	1
705*†	123743	SPRING, compression	1
706*	16C490	CAP, check valve, external mix	1
708	262697	INSERT, valve assist, asm, ext mix	1
708a	111504	O-RING	3
709★	262699	AIR CAP, vertical (Model 24E427 only)	1
*	262700	AIR CAP, horizontal (Model 24E426 only)	1
710✿★★	16E376	RING, retaining	1
711	GC2081	SCREW, set, flat point	1
712✿★★	15G998	WASHER	1
713✿★★	107313	PACKING, o-ring	1
717*†	113137	PACKING, o-ring	1
718*†	168588	WASHER, non-metallic	1

* Parts available in external mix front head check valve kit 24E446.

† Parts available in external mix front head check valve repair kit 24E447.

✿ Parts included in retaining ring kit 24H274.

★ Parts included in horizontal air cap kit 24H275.

★ Parts included in vertical air cap kit 24H283.

Internal Mix Gel Front Head, 24G615
Internal Mix Chop Front Head, 24E442

NOTICE

There is a half-moon pin pressed into the front head (801) behind the diffuser assembly (803). Do not attempt to remove this pin. Removal will result in poor mixing.

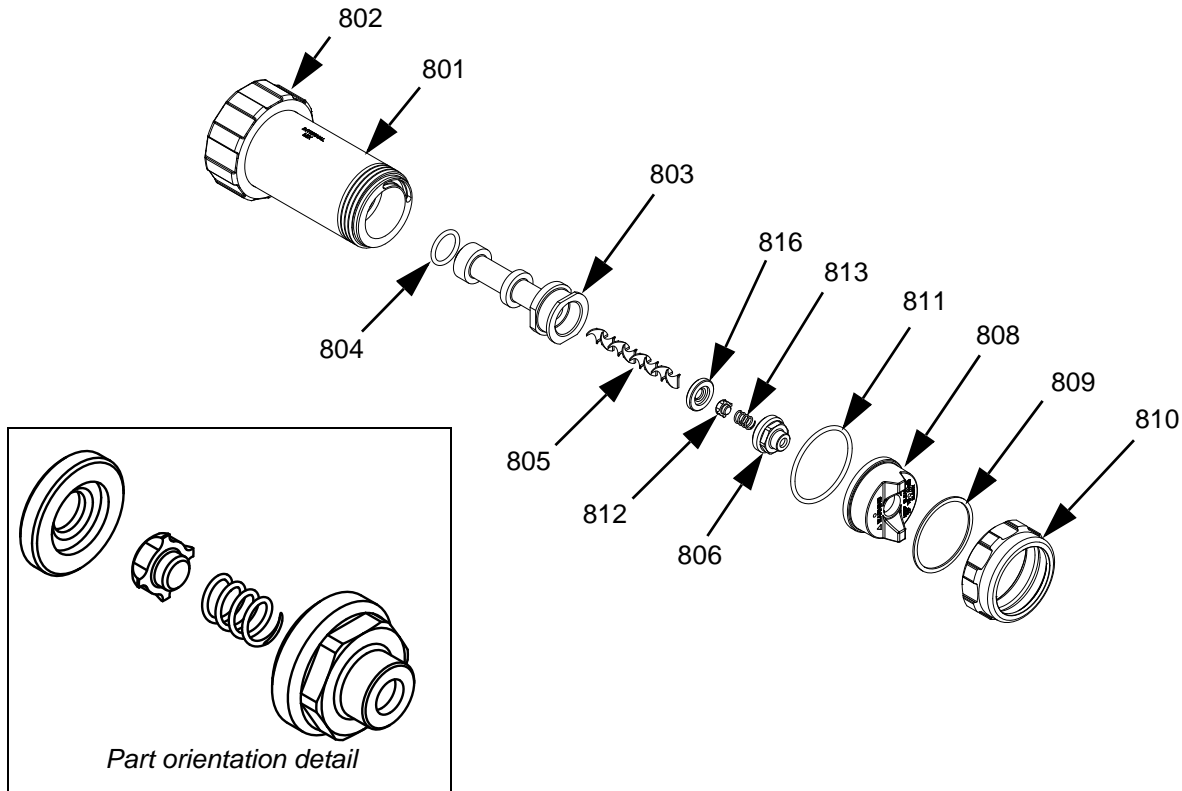

Ref	Part	Description	Qty	
801	262703	HEAD, spray, internal	1	* Parts available in internal mix front head check valve kit 24E443.
802	16C220	RING, locking	1	
803	16C327	DIFFUSER, internal mix	1	† Parts available in internal mix check valve spring kit 24E444.
804	113746	PACKING, o-ring	1	
805*	16C300	ELEMENT, mixing, internal mix	1	✿ Parts included in retaining ring kit 24H274.
806*	16C397	CAP, check valve, internal mix	1	✱ Parts included in internal mix chop air cap kit 24H277.
808*	262701	AIR CAP, asm, internal mix, chop (Model 24E442 only)	1	
★	262702	AIR CAP, asm, internal mix, gel coat (Model 24G615 only)	1	★ Parts included in internal mix gel air cap kit 24H278.
809✿✱★	15G998	WASHER	1	
810✿✱★	16E376	RING, retaining	1	
811✿✱★	107313	PACKING, o-ring	1	
812*†	16C408	VALVE, check, internal mix	1	
813*†	123734	SPRING, compression	1	
816*†	16F323	SEAT, check valve, int mix	1	

Internal Mix, High Flow Chop Front Head, 24P562

NOTICE

There is a half-moon pin pressed into the front head (801) behind the diffuser assembly (803). Do not attempt to remove this pin. Removal will result in poor mixing.

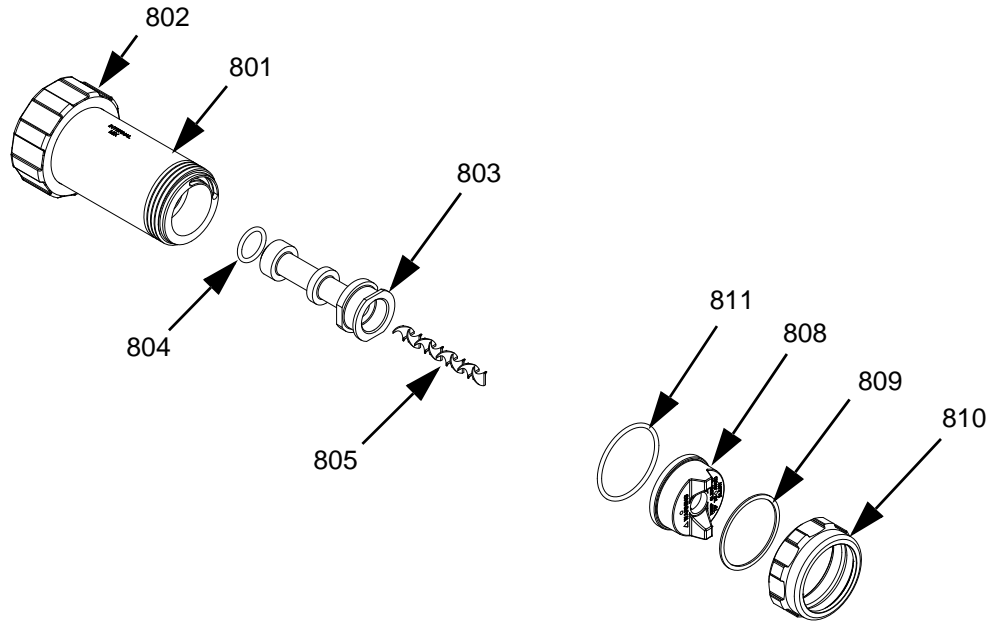

Ref	Part	Description	Qty	
801	262703	HEAD, spray, internal	1	
802	16C220	RING, locking	1	
803	16G806	DIFFUSER, internal mix, 3/8	1	
804	113746	PACKING, o-ring	1	
805	20310-90	ELEMENT, mixing, spiral	1	
808*	262701	AIR CAP, asm, internal mix, chop (Model 24E442 only)	1	* Parts included in internal mix chop air cap kit 24H277.
★	262702	AIR CAP, asm, internal mix, gel coat (Model 24G615 only)	1	★ Parts included in internal mix gel air cap kit 24H278.
809**★	15G998	WASHER	1	
810**★	16E376	RING, retaining	1	
811**★	107313	PACKING, o-ring	1	

Needle Assembly, 24E417

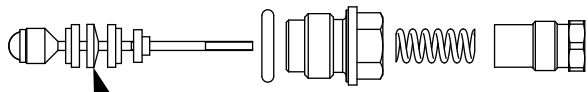
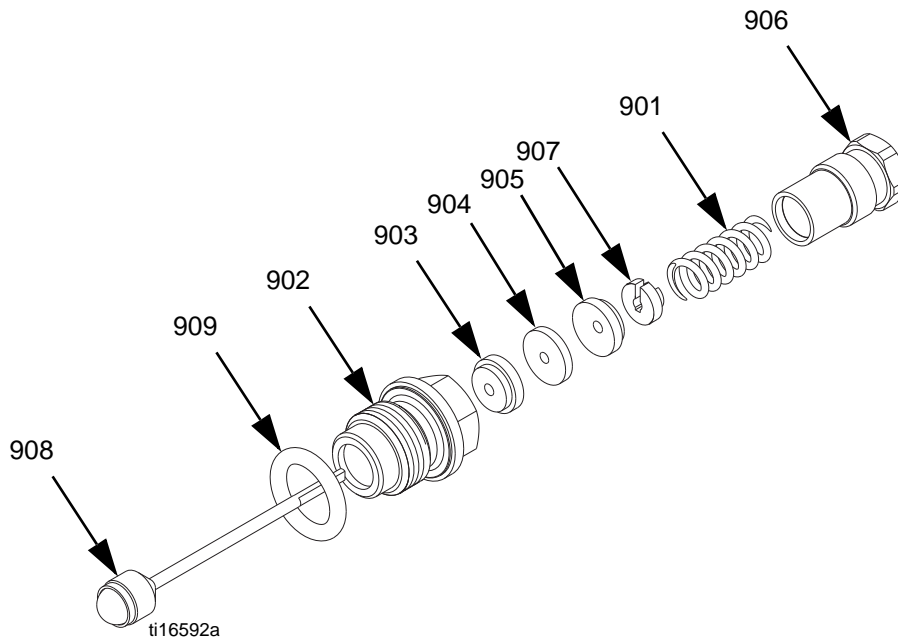

Beveled edge must face rear of needle

Ref	Part	Description	Qty
901	123634	SPRING, needle assembly	1
902	16C080	HOUSING, needle packing	1
903*	16C081	RETAINER, packing	1
904*	24H279	PACKING, disk (pack of 6)	1
905*	16C083	RETAINER, packing	1
906	16C086	NUT, packing material	1
907*	16C087	CLIP, retainer	1
908	24C780	NEEDLE, assembly	1
909*	24H281	O-RING (pack of 6)	1

* Parts included in needle repair kit 24E418.

O-ring Identification

The following illustration shows all available o-rings at actual size. See the respective illustration in the **Parts** section beginning on page 38 for part references and locations.

White (PTFE) O-rings

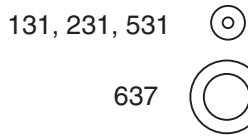

713, 811

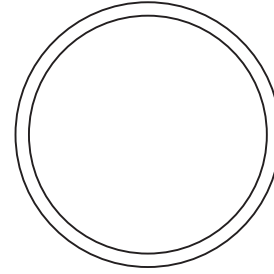

Black (FKM) O-rings

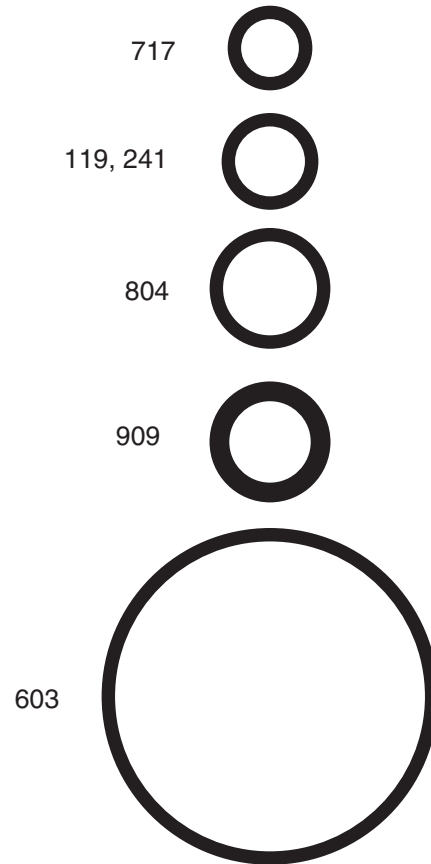
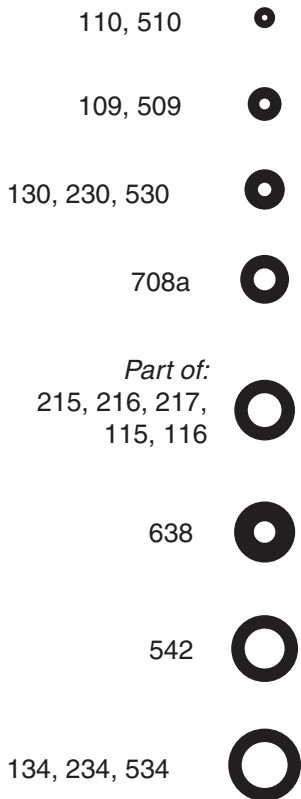

Accessories

Fusion[®] Grease

118665, 4 oz. (113 gram)

High adhesion, water resistant, lithium-based lubricant. Use this to lubricate the gun. MSDS sheets available at www.graco.com.

INDy or Formula Adapter Kit, 125797

Ideal for mounting an RS gun in place of an INDy or Formula gun. Kit includes the necessary items to connect the RS gun to the connections used by INDy and Formula guns.

LPA2 Adapter Kit, 125843

Ideal for mounting an RS gun in place of an LPA2 gun. Kit includes the necessary items to connect the RS gun to the connections used by the LPA2 gun.

NOTE: An air assist tube and a catalyst hose are required to mount the RS gun in place of the LPA2 gun but they are not included in this kit. The existing air assist tube or catalyst hose may be able to be re-used. See the following table if additional parts are needed.

Part	Description
9704-83	Air Assist Tube (order by the foot)
24C540	25 ft Catalyst Hose
24G429	35 ft Catalyst Hose
24C541	50 ft Catalyst Hose

Universal Adapter Kit, 257754

Allows the flexibility to mount an RS gun in place of a variety of guns, including competitor guns.

Resin Transfer Molding (RTM) Nozzle Adapter Kit, 16T680

Ideal for resin transfer molding applications.

Casting Nozzle Adapter Kit, 16T707

Ideal for casting nozzle applications.

External Mix High-Flow Kit, 24H336

Use this kit to replace the external mix front head check valve assembly with a non-check valve spacer in order to increase the output. See check valve assembly kit 24E446 parts shown in the **Front Head Assemblies** section on page 49.

NOTE: This kit replaces the check valve.

Part	Description	Qty
113137	O-RING	1
16G800	SPACER, tip, external mix	1

Internal Mix High-Flow Kit, 24H337

Use this kit to replace the standard 1/4 in. mixer in the internal mix front head assembly with a 3/8 in. mixer in order to increase the output. The kit includes a new diffuser assembly which does not use or require a check valve.

NOTE: This kit replaces the entire diffuser assembly, including a check valve, and the new diffuser does not use or require a check valve.

Part	Description	Qty
16G806	DIFFUSER, internal mix, 3/8 in.	1
113746	O-RING	1
20310-90	ELEMENT, mixing, 3/8 in.	1

AAC Regulators

24G571 - for use with internal mix gel guns

22632-00 - for use with internal mix chop guns

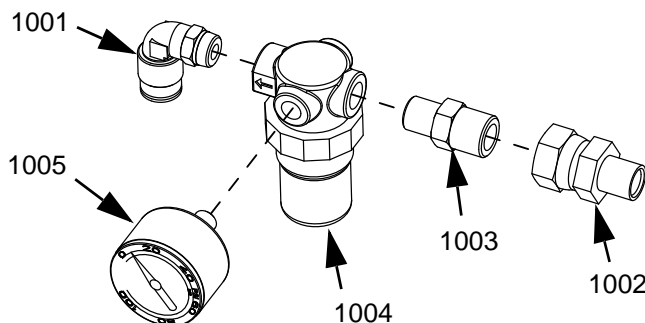

24G571_3A0232_1a

Ref	Part	Description	Qty
1001	115841	FITTING, elbow (Assembly 24G571 only)	1
	20735-02	FITTING, elbow (Assembly 22632-00 only)	1
1002	7597-04	FITTING, swivel, 3/8 nptm x 3/8 npsm	1
1003	8115-06	FITTING, pipe, nipple, hex, 3/8 x 1/4	1
1004	ISD-141-3	REGULATOR, mini	1
1005	ISD-142	GAUGE, pot, solvent	1

External Mix Gel Gun to Chop Gun Conversion

To convert your external mix gel gun to a chop gun, purchase and install the following kits:

- External Mix Cutter Adapter Kit, 24E422
- Trigger Air Valve Kit, 24E425
- Cutter Assembly, 24E512

To complete the conversion from an external mix gel gun to a chop gun, remove catalyst restrictor (153) from gun. See **External Mix Gel Gun, 258840** on page 38.

Internal Mix Gel Gun to Chop Gun Conversion

To convert your internal mix gel gun to a chop gun, purchase and install the following kits:

- Internal Mix Cutter Adapter Kit, 24G832
- Trigger Air Valve Kit, 24E425
- Cutter Assembly, 24E512
- Blank Housing Assembly, 24M045

To complete the conversion from an internal mix gel gun to a chop gun, replace housing (216) from gun. See **Internal Mix Gel Gun, 258853** on page 40.

Pressure Fed Roller Adapter Kit, 16T708

Ideal for pressure feed rolling with the RS gun.

Application Specific:

Part	Description	Qty
232122	EXTENSION, roller, fixed (0.5 meter)	1
244163	EXTENSION, pole gun, 3 feet	1
244164	EXTENSION, pole gun, 6 feet	1

Extension Gelcoat Spraying Kit, 16T709

For spraying into deep channels.

Application Specific:

Part	Description	Qty
XHD117	TIP, spray, cylinder (117)	1
XHD119	TIP, spray, cylinder (119)	1
XHD121	TIP, spray, cylinder (121)	1
XHD217	TIP, spray, cylinder (217)	1
XHD219	TIP, spray, cylinder (219)	1
XHD221	TIP, spray, cylinder (221)	1
XHD225	TIP, spray, cylinder (225)	1
XHD227	TIP, spray, cylinder (227)	1
XHD229	TIP, spray, cylinder (229)	1
XHD231	TIP, spray, cylinder (231)	1
XHD235	TIP, spray, cylinder (235)	1
XHD239	TIP, spray, cylinder (239)	1

Tools

Hex Keys for Guns, 24F007

Includes:

- One 3/32 in. hex key
- One 9/64 in. hex key
- One 3/16 in. hex key

Carbide Resin Seat, 16N889

Ideal for use with heavily filled materials. It is to replace standard resin seat 16C104.

External Mix Chopper Extension Kit, 24V096

For extending the chopper assembly on external mix chopper guns.

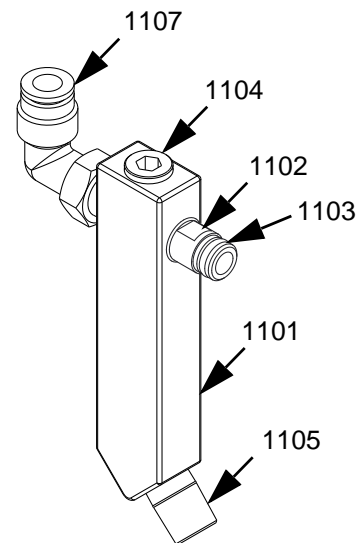

Ref	Part	Description	Qty
1101	16X784	FITTING, extension	1
1102	16F501	TUBE, air pivot	1
1103	111516	PACKING, o-ring	1
1104	295662	PLUG, pipe	1
1105	127367	FITTING, nipple, 1/8 NPT	1
1107	125412	FITTING, elbow	1

Impingement Spray Tips

Pattern Width ♦ Increases

	6 in. (15 cm)	8 in. (20 cm)	10 in. (25 cm)	12 in. (30 cm)	14 in. (36 cm)	16 in. (41 cm)	18 in. (46 cm)
	CSTS31	CSTS41	CSTS51	CSTS61	CSTS71	CSTS81	CSTS91
	CSTS32	CSTS42	CSTS52	CSTS62	CSTS72	CSTS82	CSTS92
	CSTS33	CSTS43	CSTS53	CSTS63	CSTS73	CSTS83	
	CSTS34	CSTS44	CSTS54	CSTS64	CSTS74	CSTS84	
	CSTS35	CSTS45	CSTS55	CSTS65	CSTS75	CSTS85	
	CSTS36*	CSTS46*	CSTS56*	CSTS66*	CSTS76*	CSTS86*	
	CSTS37*	CSTS47*	CSTS57*	CSTS67*	CSTS77	CSTS87	
			CSTS58	CSTS68	CSTS78	CSTS88	

*Available in tooling steel

RS Gun Impingement Spray Tip Part No. †	Angled Hole Diameter	Straight Hole Diameter	Pattern Width ♦	GlasCraft® Tip Part No. Ref
CSTS31	0.018 in. (0.46 mm)	0.012 in. (0.30 mm)	6 in. (150 mm)	23005-C1
CSTS32	0.021 (0.53)	0.014 (0.36)	6 (150)	23005-C2
CSTS33	0.036 (0.91)	0.025 (0.64)	6 (150)	23005-C3
CSTS34	0.042 (1.07)	0.029 (0.74)	6 (150)	23005-C4
CSTS35	0.052 (1.32)	0.036 (0.91)	6 (150)	23005-C5
CSTS36	0.062 (1.57)	0.043 (1.09)	6 (150)	23005-C6
CSTS37	0.070 (1.78)	0.052 (1.32)	6 (150)	23005-C7
CSTS41	0.018 (0.46)	0.012 (0.30)	8 (200)	23005-E1
CSTS42	0.021 (0.53)	0.014 (0.36)	8 (200)	23005-E2
CSTS43	0.036 (0.91)	0.025 (0.64)	8 (200)	23005-E3
CSTS44	0.042 (1.07)	0.029 (0.74)	8 (200)	23005-E4
CSTS45	0.052 (1.32)	0.036 (0.91)	8 (200)	23005-E5
CSTS46	0.062 (1.57)	0.043 (1.09)	8 (200)	23005-E6
CSTS47	0.070 (1.78)	0.052 (1.32)	8 (200)	23005-E7
CSTS51	0.018 (0.46)	0.012 (0.30)	10 (250)	23005-G1
CSTS52	0.021 (0.53)	0.014 (0.36)	10 (250)	23005-G2
CSTS53	0.036 (0.91)	0.025 (0.64)	10 (250)	23005-G3
CSTS54	0.042 (1.07)	0.029 (0.74)	10 (250)	23005-G4
CSTS55	0.052 (1.32)	0.036 (0.91)	10 (250)	23005-G5
CSTS56	0.062 (1.57)	0.043 (1.09)	10 (250)	23005-G6
CSTS57	0.070 (1.78)	0.052 (1.32)	10 (250)	23005-G7
CSTS58	0.081 (2.06)	0.055 (1.40)	10 (250)	23005-G8

RS Gun Impingement Spray Tip Part No. †	Angled Hole Diameter	Straight Hole Diameter	Pattern Width ◆	GlasCraft® Tip Part No. Ref
CSTS61	0.018 (0.46)	0.012 (0.30)	12 (300)	23005-J1
CSTS62	0.021 (0.53)	0.014 (0.36)	12 (300)	23005-J2
CSTS63	0.036 (0.91)	0.025 (0.64)	12 (300)	23005-J3
CSTS64	0.042 (1.07)	0.029 (0.74)	12 (300)	23005-J4
CSTS65	0.052 (1.32)	0.036 (0.91)	12 (300)	23005-J5
CSTS66	0.062 (1.57)	0.043 (1.09)	12 (300)	23005-J6
CSTS67	0.070 (1.78)	0.052 (1.32)	12 (300)	23005-J7
CSTS68	0.081 (2.06)	0.055 (1.40)	12 (300)	23005-J8
CSTS71	0.018 (0.46)	0.012 (0.30)	14 (350)	23005-K1
CSTS72	0.021 (0.53)	0.014 (0.36)	14 (350)	23005-K2
CSTS73	0.036 (0.91)	0.025 (0.64)	14 (350)	23005-K3
CSTS74	0.042 (1.07)	0.029 (0.74)	14 (350)	23005-K4
CSTS75	0.052 (1.32)	0.036 (0.91)	14 (350)	23005-K5
CSTS76	0.062 (1.57)	0.043 (1.09)	14 (350)	23005-K6
CSTS77	0.070 (1.78)	0.052 (1.32)	14 (350)	23005-K7
CSTS78	0.081 (2.06)	0.055 (1.40)	14 (350)	23005-K8
CSTS81	0.018 (0.46)	0.012 (0.30)	16 (400)	23005-M1
CSTS82	0.021 (0.53)	0.014 (0.36)	16 (400)	23005-M2
CSTS83	0.036 (0.91)	0.025 (0.64)	16 (400)	23005-M3
CSTS84	0.042 (1.07)	0.029 (0.74)	16 (400)	23005-M4
CSTS85	0.052 (1.32)	0.036 (0.91)	16 (400)	23005-M5
CSTS86	0.062 (1.57)	0.043 (1.09)	16 (400)	23005-M6
CSTS87	0.070 (1.78)	0.052 (1.32)	16 (400)	23005-M7
CSTS88	0.081 (2.06)	0.055 (1.40)	16 (400)	23005-M8
CSTS91	0.018 (0.46)	0.012 (0.30)	18 (450)	23005-P1
CSTS92	0.021 (0.53)	0.014 (0.36)	18 (450)	23005-P2
CSTT36	0.062 (1.57)	0.043 (1.09)	6 (150)	23005-TC6
CSTT37	0.070 (1.78)	0.052 (1.32)	6 (150)	23005-TC7
CSTT46	0.062 (1.57)	0.043 (1.09)	8 (200)	23005-TE6
CSTT47	0.070 (1.78)	0.052 (1.32)	8 (200)	23005-TE7
CSTT56	0.062 (1.57)	0.043 (1.09)	10 (250)	23005-TG6
CSTT57	0.070 (1.78)	0.052 (1.32)	10 (250)	23005-TG7
CSTT66	0.062 (1.57)	0.043 (1.09)	12 (300)	23005-TJ6
CSTT67	0.070 (1.78)	0.052 (1.32)	12 (300)	23005-TJ7
CSTT76	0.062 (1.57)	0.043 (1.09)	14 (350)	23005-TK6
CSTT86	0.062 (1.57)	0.043 (1.09)	16 (400)	23005-TM6

† **Tip Code Reference:**

CST = Composite Spray Tip

4th digit = S for stainless steel, T for tool steel

Accessories

5th digit = pattern width code. Double number to get pattern size at 18 in. (450 mm). Example: 5 = 10 in. (250 mm) pattern at 18 in. (450 mm) distance to target.

6th digit = orifice size code. Number roughly matches a 0.010 in. (0.254 mm) increment of the angled hole dia. Exp: 5 = 0.052 in. (1.32 mm) dia. angled holes.

- ◆ *Approximate pattern width at 18 in. (45 cm) to target. Actual pattern width varies depending on various conditions.*

Airless Spray Tips

Pattern Width ♦ Increases

	4 in. (10 cm)	6 in. (15 cm)	8 in. (20 cm)	10 in. (25 cm)	12 in. (30 cm)
Flow Increases	CST215	CST315	CST415	CST515	CST615
	CST217	CST317	CST417	CST517	CST617
	CST219	CST319	CST419	CST519	CST619
	CST221	CST321	CST421	CST521	CST621
	CST223	CST323	CST423	CST523	CST623
	CST227	CST327	CST427	CST527	CST627
	CST231	CST331	CST431	CST531	CST631
	CST235	CST335	CST435	CST535	CST635
		CST343	CST443	CST543	CST643
		CST351	CST451	CST551	CST651
			CST461	CST561	CST661
			CST471	CST571	CST671

RS Gun Airless Spray Tip Part No. †	Orifice Diameter	Pattern Width ♦	GlasCraft Tip Part No. Ref
CST215	0.015 in. (0.38 mm)	4-6 in. (100-150 mm)	LPA2-147-1525
CST217	0.017 (0.43)	4-6 (100-150)	LPA2-147-1825
CST219	0.019 (0.48)	4-6 (100-150)	---
CST221	0.021 (0.53)	4-6 (100-150)	LPA2-147-2125
CST223	0.023 (0.58)	4-6 (100-150)	LPA2-147-2325
CST227	0.027 (0.69)	4-6 (100-150)	---
CST231	0.031 (0.79)	4-6 (100-150)	LPA2-147-3125
CST235	0.035 (0.89)	4-6 (100-150)	LPA2-147-3625
CST315	0.015 (0.38)	6-8 (150-200)	---
CST317	0.017 (0.43)	6-8 (150-200)	---
CST319	0.019 (0.48)	6-8 (150-200)	---
CST321	0.021 (0.53)	6-8 (150-200)	---
CST323	0.023 (0.58)	6-8 (150-200)	---
CST327	0.027 (0.69)	6-8 (150-200)	---
CST331	0.031 (0.79)	6-8 (150-200)	---
CST335	0.035 (0.89)	6-8 (150-200)	---
CST343	0.043 (1.09)	6-8 (150-200)	LPA2-147-4325
CST351	0.051 (1.30)	6-8 (150-200)	LPA2-147-5225
CST415	0.015 (0.38)	8-10 (200-250)	LPA2-147-1540
CST417	0.017 (0.43)	8-10 (200-250)	LPA2-147-1840
CST419	0.019 (0.48)	8-10 (200-250)	---

RS Gun Airless Spray Tip Part No. †	Orifice Diameter	Pattern Width ◆	GlasCraft Tip Part No. Ref
CST421	0.021 (0.53)	8-10 (200-250)	LPA2-147-2140
CST423	0.023 (0.58)	8-10 (200-250)	LPA2-147-2340
CST425	0.025 (0.64)	8-10 (200-250)	---
CST427	0.027 (0.69)	8-10 (200-250)	LPA2-147-2640
CST431	0.031 (0.79)	8-10 (200-250)	LPA2-147-3140
CST435	0.035 (0.89)	8-10 (200-250)	LPA2-147-3640
CST443	0.043 (1.09)	8-10 (200-250)	LPA2-147-4340
CST451	0.051 (1.30)	8-10 (200-250)	LPA2-147-5240
CST461	0.061 (1.55)	8-10 (200-250)	LPA2-147-6240
CST471	0.071 (1.80)	8-10 (200-250)	LPA2-147-7240
CST515	0.015 (0.38)	10-12 (250-300)	---
CST517	0.017 (0.43)	10-12 (250-300)	LPA2-147-1850
CST519	0.019 (0.48)	10-12 (250-300)	---
CST521	0.021 (0.53)	10-12 (250-300)	LPA2-147-2150
CST523	0.023 (0.58)	10-12 (250-300)	LPA2-147-2350
CST527	0.027 (0.69)	10-12 (250-300)	LPA2-147-2650
CST531	0.031 (0.79)	10-12 (250-300)	LPA2-147-3150
CST535	0.035 (0.89)	10-12 (250-300)	LPA2-147-3650
CST543	0.043 (1.09)	10-12 (250-300)	LPA2-147-4350
CST551	0.051 (1.30)	10-12 (250-300)	LPA2-147-5250
CST561	0.061 (1.55)	10-12 (250-300)	LPA2-147-6250
CST571	0.071 (1.80)	10-12 (250-300)	---
CST615	0.015 (0.38)	12-14 (300-350)	---
CST617	0.017 (0.43)	12-14 (300-350)	---
CST619	0.019 (0.48)	12-14 (300-350)	---
CST621	0.021 (0.53)	12-14 (300-350)	---
CST623	0.023 (0.58)	12-14 (300-350)	---
CST627	0.027 (0.69)	12-14 (300-350)	---
CST631	0.031 (0.79)	12-14 (300-350)	---
CST635	0.035 (0.89)	12-14 (300-350)	---
CST643	0.043 (1.09)	12-14 (300-350)	---
CST651	0.051 (1.30)	12-14 (300-350)	LPA2-147-5265
CST661	0.061 (1.55)	12-14 (300-350)	LPA2-147-6265
CST671	0.071 (1.80)	12-14 (300-350)	---

† **Tip Code Reference:**

CST = Composite Spray Tip

4th digit = pattern width code. Double number to get pattern size at 12 in. (305 mm). Example: 5 = 10 in. (250 mm) pattern at 12 in. (305 mm) distance to target.

5th & 6th digit = equivalent orifice size as a round diameter orifice.

◆ Approximate pattern width at 12 in. (30 cm) to target. Actual pattern width varies depending on various conditions.

Technical Data

See **Models** on page 3 for more information.

RS Gun and Cutter		
	US	Metric
Maximum Fluid Working Pressure		
Internal Mix		
258853	2000 psi	138 bar, 14 MPa
258854	2000 psi	138 bar, 14 MPa
258971	2000 psi	138 bar, 14 MPa
24P435	2000 psi	138 bar, 14 MPa
External Mix		
258840	2000 psi	138 bar, 14 MPa
258852	2000 psi	138 bar, 14 MPa
258970	2000 psi	138 bar, 14 MPa
Maximum Catalyst Working Pressure		
258853	2000 psi	138 bar, 14 MPa
258854	2000 psi	138 bar, 14 MPa
258971	2000 psi	138 bar, 14 MPa
24P435	2000 psi	138 bar, 14 MPa
258840	200 psi	14 bar, 1.4 MPa
258852	200 psi	14 bar, 1.4 MPa
258970	200 psi	14 bar, 1.4 MPa
Air Inlet Working Pressure		
258853	0-125 psi	0-8.6 bar, 0-0.86 MPa
258854	0-125 psi	0-8.6 bar, 0-0.86 MPa
258971	80-125 psi	5.5-8.6 bar, 0.55-0.86 MPa
24P435	80-125 psi	5.5-8.6 bar, 0.55-0.86 MPa
258840	0-125 psi	0-8.6 bar, 0-0.86 MPa
258852	0-125 psi	0-8.6 bar, 0-0.86 MPa
258970	80-125 psi	5.5-8.6 bar, 0.55-0.86 MPa
Maximum Fluid Temperature		
258853	100°F	38°C
258854	100°F	38°C
258971	100°F	38°C
24P435	100°F	38°C
258840	100°F	38°C
258852	100°F	38°C
258970	100°F	38°C
Minimum Air Flow (at 100 psi, 7 bar, 0.7 Mpa)		
258853	12.5 scfm	0.375 m ³ per min.
258854	2.25 scfm	0.064 m ³ per min.
258840	2.0 scfm	0.06 m ³ per min.
24E512	16.5 scfm	0.47 m ³ per min.

RS Gun and Cutter		
	US	Metric
Weight		
258853	2.32 lb	1.05 kg
258854	2.46 lb	1.12 kg
258840	2.08 lb	0.94 kg
258852	2.33 lb	1.04 kg
Sound Power Measured per ISO-3746		
258853	98.1 dB (A) at 60 psig	
258854	90.6 dB(A) at 50 psig	
258840	90.8 dB(A) at 50 psig	
Sound Pressure Measured at 3 ft (1 m) from equipment.		
258853	80.3 dB (A) at 60 psig	
258854	72.8 dB(A) at 50 psig	
258840	73.0 dB(A) at 50 psig	
Wetted Parts	Aluminum, stainless steel, carbon steel, carbide, chemically resistant o-rings	
Materials of Construction	Aluminum, stainless steel, carbon steel, carbide, chemically resistant o-rings	
Maximum Air Pressure	125 psi	9 bar, 0.9 MPa
Maximum Fluid Temperature	100°F	38°C

Dimensions

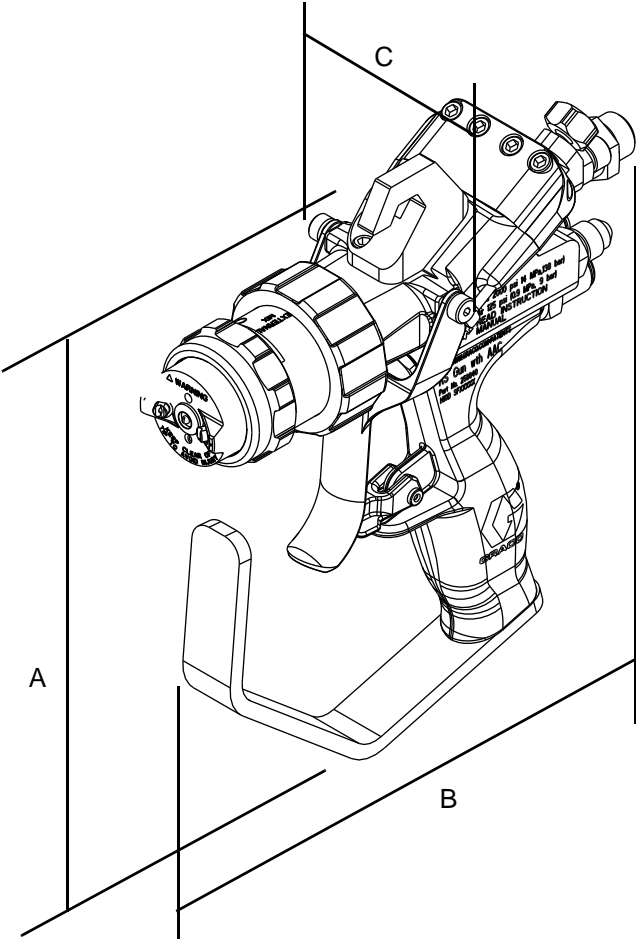

258840_3A0232_1g

	Dimensions; in. (mm)			
	External, Gel	Internal, Gel	Internal, Chop	External, Chop
A, Height	7.37 (187)	7.37 (187)	10.29 (261.4)	10.29 (261.4)
B, Length	7.60 (193)	9.2 (234)	9.2 (234)	7.60 (193)
C, Width	2.36 (59.9)	2.36 (59.9)	5.07 (129)	5.07 (129)

Graco Standard Warranty

Graco warrants all equipment referenced in this document which is manufactured by Graco and bearing its name to be free from defects in material and workmanship on the date of sale to the original purchaser for use. With the exception of any special, extended, or limited warranty published by Graco, Graco will, for a period of twelve months from the date of sale, repair or replace any part of the equipment determined by Graco to be defective. This warranty applies only when the equipment is installed, operated and maintained in accordance with Graco's written recommendations.

This warranty does not cover, and Graco shall not be liable for general wear and tear, or any malfunction, damage or wear caused by faulty installation, misapplication, abrasion, corrosion, inadequate or improper maintenance, negligence, accident, tampering, or substitution of non-Graco component parts. Nor shall Graco be liable for malfunction, damage or wear caused by the incompatibility of Graco equipment with structures, accessories, equipment or materials not supplied by Graco, or the improper design, manufacture, installation, operation or maintenance of structures, accessories, equipment or materials not supplied by Graco.

This warranty is conditioned upon the prepaid return of the equipment claimed to be defective to an authorized Graco distributor for verification of the claimed defect. If the claimed defect is verified, Graco will repair or replace free of charge any defective parts. The equipment will be returned to the original purchaser transportation prepaid. If inspection of the equipment does not disclose any defect in material or workmanship, repairs will be made at a reasonable charge, which charges may include the costs of parts, labor, and transportation.

THIS WARRANTY IS EXCLUSIVE, AND IS IN LIEU OF ANY OTHER WARRANTIES, EXPRESS OR IMPLIED, INCLUDING BUT NOT LIMITED TO WARRANTY OF MERCHANTABILITY OR WARRANTY OF FITNESS FOR A PARTICULAR PURPOSE.

Graco's sole obligation and buyer's sole remedy for any breach of warranty shall be as set forth above. The buyer agrees that no other remedy (including, but not limited to, incidental or consequential damages for lost profits, lost sales, injury to person or property, or any other incidental or consequential loss) shall be available. Any action for breach of warranty must be brought within two (2) years of the date of sale.

GRACO MAKES NO WARRANTY, AND DISCLAIMS ALL IMPLIED WARRANTIES OF MERCHANTABILITY AND FITNESS FOR A PARTICULAR PURPOSE, IN CONNECTION WITH ACCESSORIES, EQUIPMENT, MATERIALS OR COMPONENTS SOLD BUT NOT MANUFACTURED BY GRACO. These items sold, but not manufactured by Graco (such as electric motors, switches, hose, etc.), are subject to the warranty, if any, of their manufacturer. Graco will provide purchaser with reasonable assistance in making any claim for breach of these warranties.

In no event will Graco be liable for indirect, incidental, special or consequential damages resulting from Graco supplying equipment hereunder, or the furnishing, performance, or use of any products or other goods sold hereto, whether due to a breach of contract, breach of warranty, the negligence of Graco, or otherwise.

FOR GRACO CANADA CUSTOMERS

The Parties acknowledge that they have required that the present document, as well as all documents, notices and legal proceedings entered into, given or instituted pursuant hereto or relating directly or indirectly hereto, be drawn up in English. Les parties reconnaissent avoir convenu que la rédaction du présente document sera en Anglais, ainsi que tous documents, avis et procédures judiciaires exécutés, donnés ou intentés, à la suite de ou en rapport, directement ou indirectement, avec les procédures concernées.

Graco Information

For the latest information about Graco products, visit www.graco.com.

For patent information, see www.graco.com/patents

TO PLACE AN ORDER, contact your Graco distributor or call to identify the nearest distributor.

Phone: 612-623-6921 or Toll Free: 1-800-746-1334 Fax: 330-966-3006

All written and visual data contained in this document reflects the latest product information available at the time of publication. Graco reserves the right to make changes at any time without notice.

Original instructions. *This manual contains English. MM 3A0232*

Graco Headquarters: Minneapolis
International Offices: Belgium, China, Japan, Korea

GRACO INC. AND SUBSIDIARIES • P.O. BOX 1441 • MINNEAPOLIS MN 55440-1441 • USA

Copyright 2010, Graco Inc. All Graco manufacturing locations are registered to ISO 9001.

www.graco.com

Revision U, October 2015